

A. D. CUTTS.
Package for Bleaching and Packing Rosin.
No. 209,384. Patented Oct. 29, 1878.

Fig. 1.

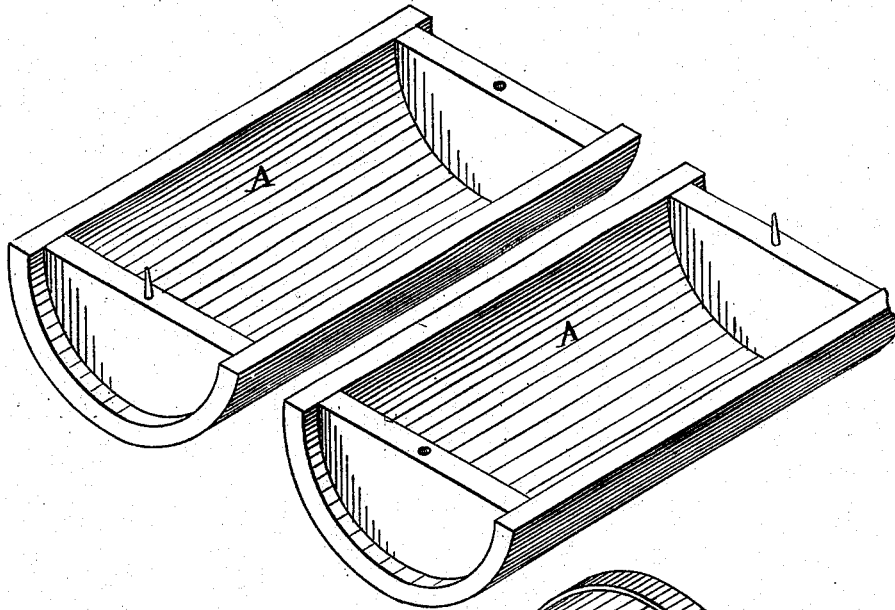
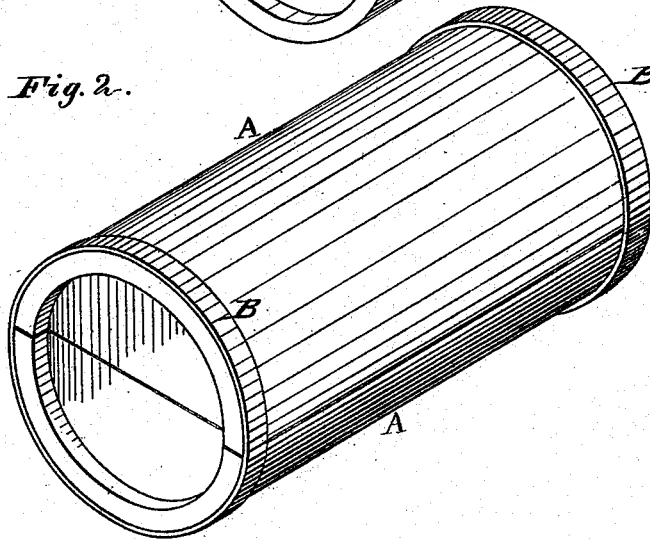

Fig. 2.



WITNESSES:

Henry N. Miller
C. Sedgwick

INVENTOR:

A. D. Cutts

BY

Munnick

ATTORNEYS.

UNITED STATES PATENT OFFICE.

ADDISON D. CUTTS, OF SCREVEN, GEORGIA.

IMPROVEMENT IN PACKAGES FOR BLEACHING AND PACKING ROSIN.

Specification forming part of Letters Patent No. **209,384**, dated October 29, 1878; application filed January 22, 1878.

To all whom it may concern:

Be it known that I, ADDISON D. CUTTS, of Screven, in the county of Wayne and State of Georgia, have invented a new and useful Improvement in Packages for Bleaching and Packing Rosin, of which the following is a specification:

In the accompanying drawing, Figure 1 represents a view of two semi-cylindrical barrel-sections, and Fig. 2 is a perspective view of the barrel-sections hooped together for shipment.

Similar letters of reference indicate corresponding parts.

The object of this invention is to provide an improved package for bleaching and packing rosin, by which the rosin is obtained and packed with a uniform degree of whiteness, without showing a grade's difference between the top and bottom of the rosin, as by the present mode of putting it up in barrels.

The rosin is bleached by my mode in simple and cheap manner by exposure to air and light, and is packed into handy and convenient form for use or transportation.

The invention will first be described in connection with the drawing, and then pointed out in the claim.

In the drawing, A represents a barrel-section, which is made preferably of semi-cylindrical shape by using straight-edged staves

and semicircular heads. The staves are equally divided around the head-sections and nailed thereto, forming thereby longitudinal sections, which are independent of—that is, unattached to—each other, and furnish a barrel without bilge when put together and bound by hoops. Each barrel-section is filled with molten rosin, and then exposed to the bleaching action of the sun and air until the required degree of whiteness is obtained. The semi-sections are then put together and bound with hoops B, forming a barrel of rosin, that is ready for market.

The advantage of this barrel for bleaching and packing consists in the great simplicity of handling the rosin and in obtaining a uniform degree of whiteness all through the rosin, which cannot be obtained by the present mode of putting it up in barrels.

Having thus described my invention, what I claim as new, and desire to secure by Letters Patent, is—

A bilgeless barrel or package consisting of two longitudinal independent semicircular wooden sections, having semicircular end heads, and secured together by end hoops, as shown and described.

ADDISON D. CUTTS.

Witnesses:

H. J. BURTON,
W. T. M. ROGERS.