

J. B. MARTIN & W. T. CAROTHERS.
Hay-Loaders.

No. 209,410.

Patented Oct. 29, 1878.

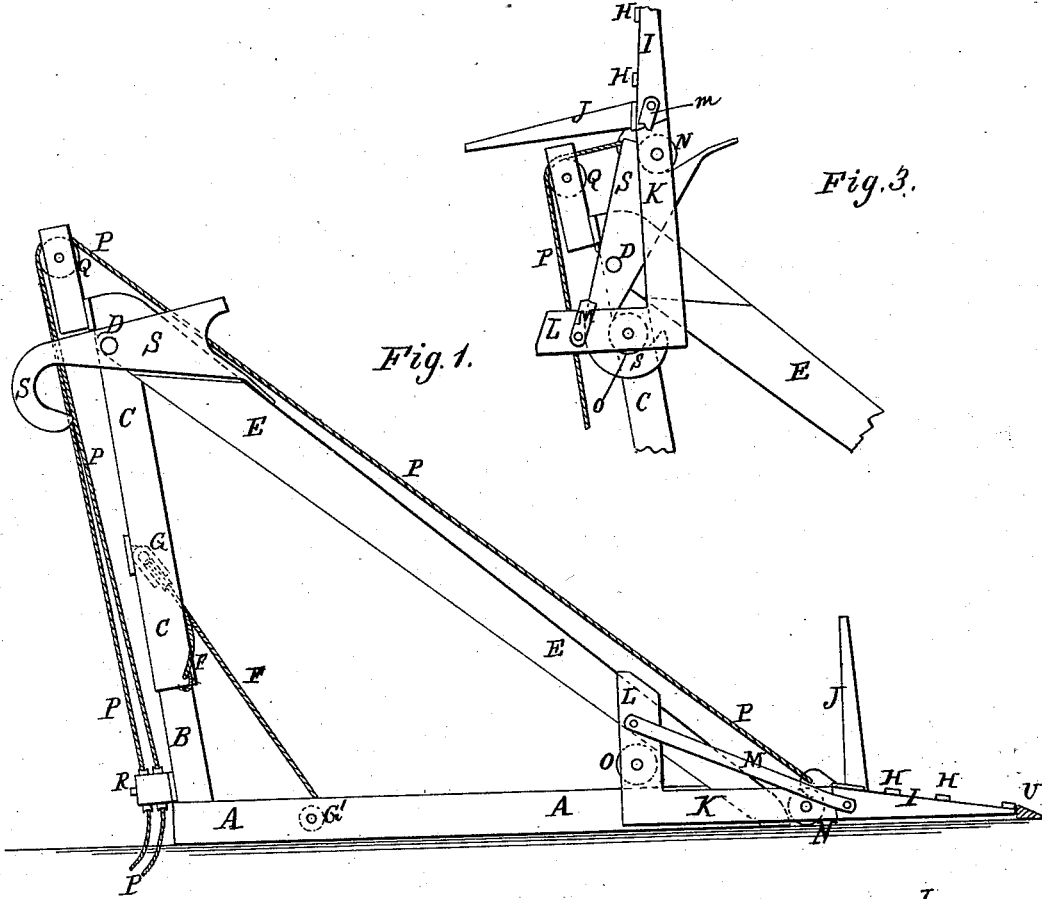

Fig. 1.

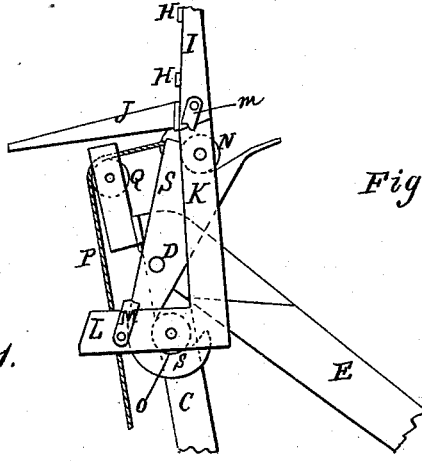

Fig. 3.

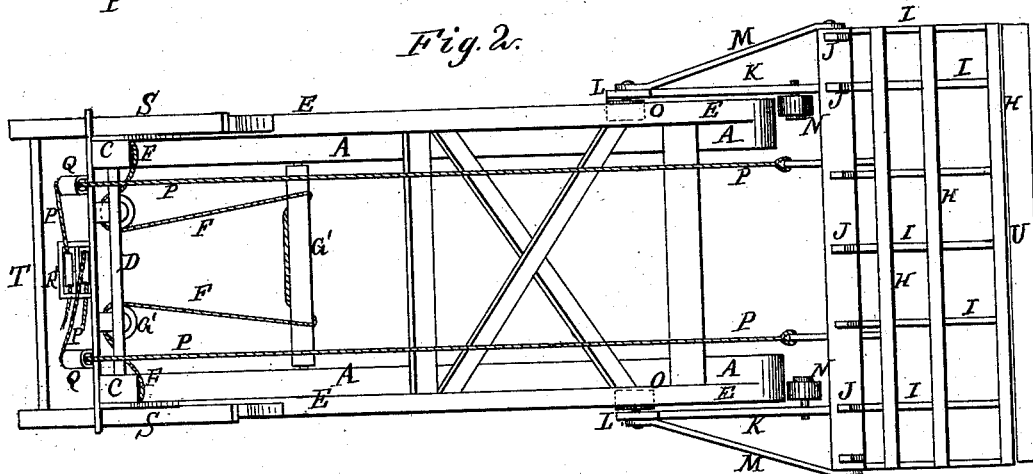

Fig. 2.

WITNESSES:

Henry N. Miller
C. Sedgwick

INVENTOR:

J. B. Martin
W. T. Carothers
BY *Munn & Co*
ATTORNEYS.

J. B. MARTIN & W. T. CAROTHERS.

Hay-Loaders.

No. 209,410.

Patented Oct. 29, 1878.

Fig. 4.

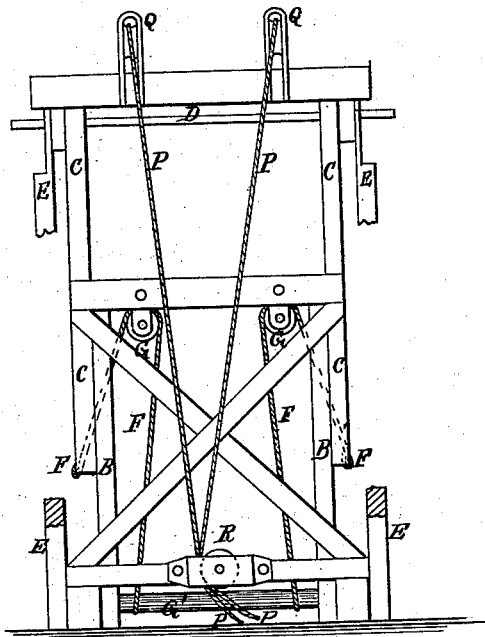

WITNESSES:

Henry N. Miller
C. Sedgwick

INVENTOR:

J. B. Martin
W. T. Carothers
BY
ATTORNEYS.

UNITED STATES PATENT OFFICE.

JOHN B. MARTIN AND WILLIAM T. CAROTHERS, OF CLARENCE, MISSOURI.

IMPROVEMENT IN HAY-LOADERS.

Specification forming part of Letters Patent No. **209,410**, dated October 29, 1878; application filed August 14, 1878.

To all whom it may concern:

Be it known that we, JOHN B. MARTIN and WILLIAM T. CAROTHERS, of Clarence, in the county of Shelby, in the State of Missouri, have invented a new and Improved Hay Pitcher or Stacker, of which the following is a specification:

Figure 1, Sheet 1, is a side view of our improved machine. Fig. 2, Sheet 1, is a top view of the same. Fig. 3, Sheet 1, is a detail view, showing the platform in position to discharge the hay. Fig. 4, Sheet 2, is a rear view of the machine, the tilting levers and the platform being removed, and part being broken away to show the construction.

Similar letters of reference indicate corresponding parts.

The object of this invention is to furnish an improved machine for placing hay upon stacks or ricks, or upon wagons, and which shall be simple in construction and convenient and reliable in use.

The invention consists in the combination of the base-frame, the upright extension-frame, and the inclined frame, to form an adjustable frame-work upon which the hay-carrying platform may be raised and lowered; in the combination of the tilting levers, provided with notches in their forward ends and with hooks in their rear ends, with the upright extension-frame and with the inclined frame, to tilt the hay-carrying platform when raised and discharge the hay; in the platform provided with the fingers, the arms and braces, and the rollers, in combination with the inclined frame of the frame-work and with the tilting levers; and in the combination of the ropes, the pulleys, and the shaft with the parts of the extension frame and with the base-frame, as hereinafter fully described.

A represents the base-frame, which consists of two sills connected together by cross-bars and braces, and which is designed to be securely staked to the ground. To the rear corners of the base-frame A are bolted the lower ends of two uprights, B, which are connected by cross-bars and braces, and upon the upper parts of which slide the upright C, also connected by cross-bars, thus forming an upright extension-frame, B C. To the upper ends of the extension-uprights C is attached,

by a rod, D, the upper ends of two inclined bars, E, which are connected by cross-bars and braces, forming an inclined frame or track. The lower ends of the inclined bars E are attached to the forward ends of the side bars of the base-frame A. The ends of the inclined frame E should be connected with the base-frame A and the upright frame B with movable joints, so that the said inclined frame E may adjust itself as the upright frame B C is extended and contracted, the said upright frame B C leaning to the rearward when contracted, and leaning forward when extended. To the lower ends of the sliding bars C of the extension-frame B C are attached the ends of two ropes, F, which pass over two pulleys, G, supported from the upper cross-bar of the lower part B of the extension-frame B C. The other ends of the ropes F are attached to a shaft, G', pivoted to the side bars of the base-frame A, and which may be turned to raise and lower the sliding part C of the extension-frame B C by means of a lever, crank, or other suitable device.

The platform is formed by attaching slats H to the upper sides of a number of bars, I, which bars are tapered, making the said platform wedge-shaped, so that a loaded hay-rake can be readily drawn upon it. To the rear side of the platform I H are attached upwardly-projecting fingers J, to keep the hay in place while being raised. To the platform I H are attached rearwardly-projecting arms K in such positions as to extend along the outer sides of the inclined bars E, and to their rear ends are attached, or upon them are formed, upwardly-projecting arms L. The arms K L are strengthened by braces M, the rear ends of which are attached to the arms L, and their forward ends are attached to the end parts of the platform I H. To the inner sides of the forward parts of the arms L are pivoted small wheels or rollers N, which roll upon the upper sides of the inclined bars E, and to the upright arms L are pivoted small wheels or rollers O, which roll upon the under sides of the inclined bars E, so as to support the platform I H in a horizontal position while passing up and down the said inclined bars E. The rollers O should be attached to the arms L adjustably, so that they may be adjusted to hold the platform I

H horizontal as the inclination of the bars E is varied by the adjustment of the extension-frame B C. To the rear side of the platform I H are attached the ends of two ropes, P, which pass over pulleys Q, pivoted to blocks or standards attached to the top cross-bar of the extension-frame B C. From the pulleys Q the ropes P pass down to and around the pulleys R, pivoted to the bottom cross-bar of the extension-frame B C, and extend out horizontally, so that the horse can be attached to them to raise the loaded platform. If desired, a single rope, P, may be used for raising the loaded platform. To the ends of the rod D are attached the middle parts of two tilting levers, S, the rear ends of which are connected by a cross-bar, T. Upon the rear ends of the levers S are formed downwardly-projecting hooks, and in their forward ends are formed round notches, as shown in Fig. 1. The outer sides of the upper ends of the inclined bars E are rabbeted to form shoulders for the forward parts of the levers S to rest upon, and to bring the forward notched ends of the said levers into such positions that the wheels N may readily pass into the said notches.

To facilitate the entrance of the rollers N into the notches in the forward ends of the levers S, the lower prongs of the said notched ends are extended and inclined downward to rest upon the upper edges of the inclined bars E, as shown in Fig. 1. With this construction, as the loaded platform reaches the upper ends of the inclined bars E, the rollers N enter the notches in the forward ends of the levers S, and the rollers O enter the cavities of the hooks upon the rear ends of the said levers. As the draft upon the ropes or rope P is continued, the levers S are turned upon their pivots D, raising the platform I H into the position shown in Fig. 3, and discharging the hay upon the stack or rick, or upon a wagon placed at the rear of the machine. The ropes P are then slackened, and the platform is allowed to run back to the ground to receive another load.

U is an inclined or wedge-shaped plank, staked to the ground directly in the front of the platform I H, when in position to receive the hay, so that the rake with which the hay is gathered may be readily drawn upon the said platform.

The hay-rake is designed to be drawn by two horses, one attached to each end, so that when the loaded rake has been drawn upon the platform I H the horses may be turned around from each other and the rake drawn back, leaving the hay upon the said platform I H.

Having fully thus described our invention, we claim as new and desire to secure by Letters Patent—

1. The combination of the base A, the uprights B, the sliding bars C, and the inclined bars E, attached to the base A and to the sliding bar C by movable joints, substantially as and for the purpose described.

2. The combination of the tilting levers S, provided with notches in their forward ends and with hooks upon their rear ends, with the upright extension-frame B C, and with the inclined frame E, to tilt the hay-carrying platform when raised and discharge the hay, substantially as herein shown and described.

3. The platform I H, provided with the fingers J, the arms and braces K I M, and the rollers N O, in combination with the inclined frame E of the frame-work, and with the tilting levers S, substantially as herein shown and described.

4. The combination of the ropes F, the pulleys G, and the shaft G' with the parts of the extension-frame B C, and with the base-frame A, substantially as herein shown and described.

JOHN B. MARTIN.

WILLIAM THOMAS CAROTHERS.

Witnesses:

C. HORNBACK,
A. S. MCAFEE.