

M. BROWN.
Machine for Cutting Blanks for Stove-Pipe Elbows
No. 209,452. Patented Oct. 29, 1878.

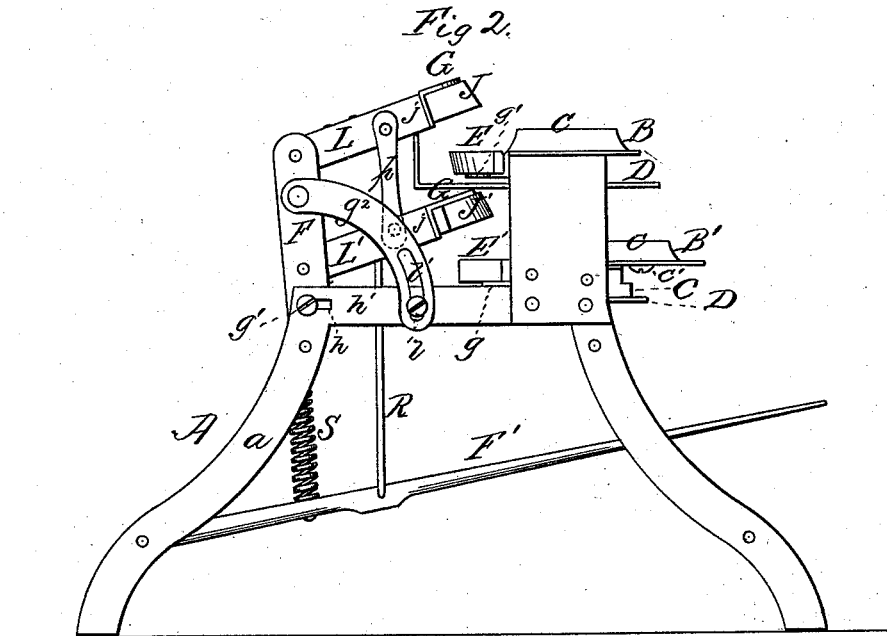
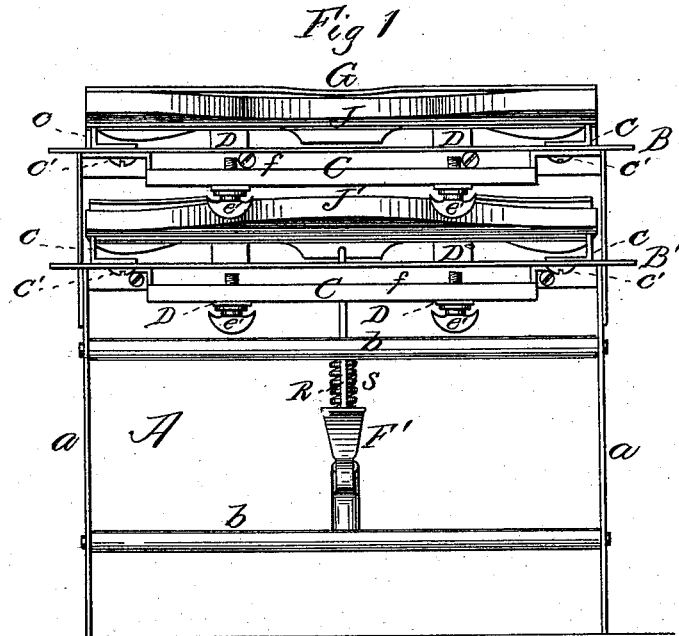

WITNESSES
Mary S. Utley
Geo C Penlton

INVENTOR
Malachi Brown
by *Edw Anderson*
ATTORNEY

M. BROWN.
Machine for Cutting Blanks for Stove-Pipe Elbows.
No. 209,452. Patented Oct. 29, 1878.

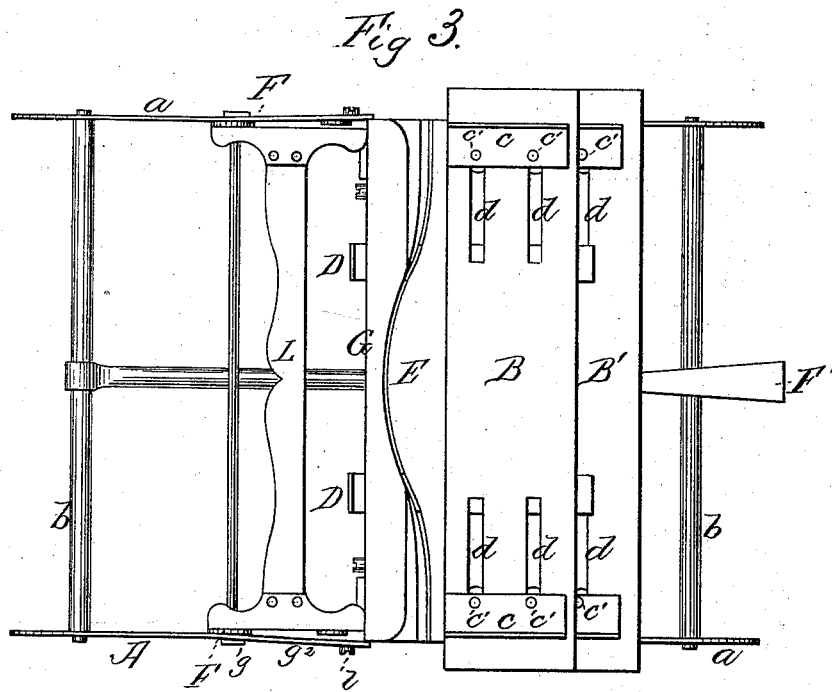

WITNESSES
Mary B. Utley
Geo. Tomlin

INVENTOR
Malachi Brown,
by E. W. Anderson,
ATTORNEY

M. BROWN.
Machine for Cutting Blanks for Stove-Pipe Elbows.
No. 209,452.

Patented Oct. 29, 1878.

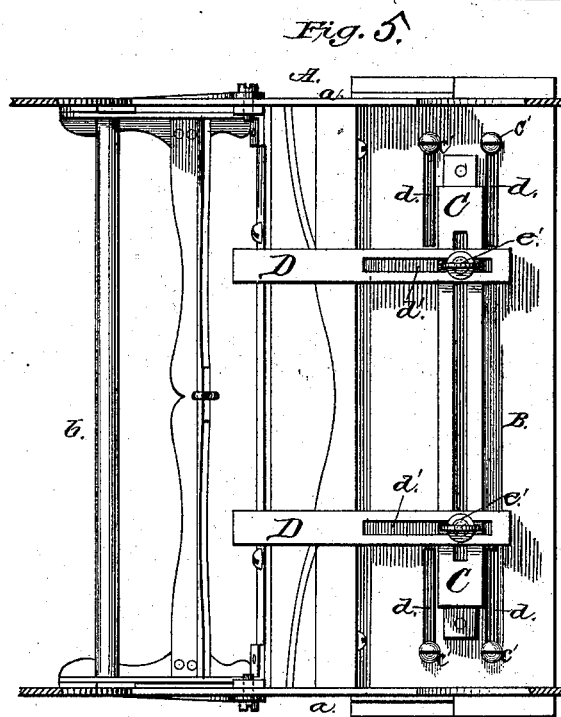
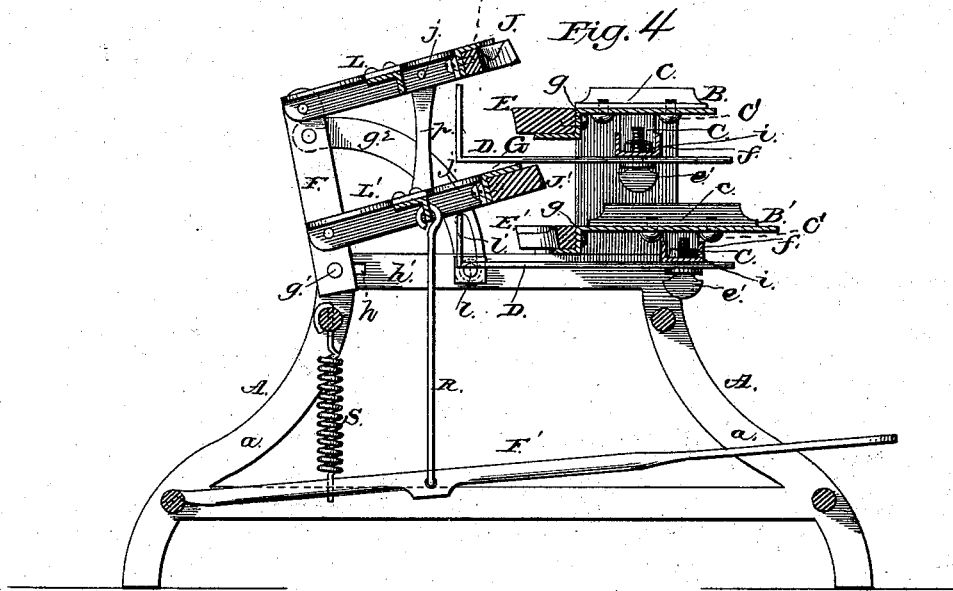

WITNESSES

John A. Ellis
F. J. Massi

INVENTOR

Malachi Brown
by E. W. Anderson

ATTORNEY

UNITED STATES PATENT OFFICE.

MALACHI BROWN, OF EAST SAGINAW, MICHIGAN, ASSIGNOR OF FIVE-NINTHS HIS RIGHT TO WILLIAM Q. ATWOOD, OF SAME PLACE.

IMPROVEMENT IN MACHINES FOR CUTTING BLANKS FOR STOVE-PIPE ELBOWS.

Specification forming part of Letters Patent No. 209,452, dated October 29, 1878; application filed July 16, 1878.

To all whom it may concern:

Be it known that I, MALACHI BROWN, of East Saginaw, in the county of Saginaw and State of Michigan, have invented a new and valuable Improvement in Machines for Cutting Blanks for Stove-Pipe Elbows; and I do hereby declare that the following is a full, clear, and exact description of the construction and operation of the same, reference being had to the annexed drawings, making a part of this specification, and to the letters and figures of reference marked thereon.

Figure 1 of the drawings is a representation of a front-end view of my improved machine. Fig. 2 is a side view of the same, and Fig. 3 is a top view thereof. Fig. 4 is a vertical section, and Fig. 5 is a bottom view.

This invention has relation to improvements in machines for cutting blanks out of sheet metal for making round pipe-elbows; and the nature of the invention consists in the combination, with a frame having parallel feed-tables, the one above the other, and provided at their rear edges with stationary cutting-blades, of uprights erected on said frame, carrying the movable cutting-blades, and adjustable toward the fixed ones, whereby as the said blades are worn away by long use and successive sharpenings, they may be adjusted toward the stationary cutters in proper condition and relation for effective use until completely worn out, all as hereinafter fully shown, described, and claimed.

In the annexed drawings, the letter A designates an upright frame, composed of two side plates, *a*, that may be made of cast-iron, connected to each other by strong braces *b*, and carrying upon its front end two parallel horizontal tables, B B', arranged the one above the other, and provided with L-shaped metallic gages *c*, that are adjustable to or from each other, according to the length of the blank. These gages also serve as guides to direct the sheet metal to the cutters, and are adjusted on the tables by means of set-screws *c'*, extending up through the parallel slots *d d'*, and engaging said guides, thus permitting them to be adjusted to or from each other. The lower table, B', extends to

the front beyond the upper table, B, for the purpose of exposing the guides and to be more conveniently adjusted. From the under sides of these tables depend the longitudinally-slotted hangers C C, arranged between the slots *d d'*, to which are adjustably secured the L-shaped guides D, that serve as stops to the sheet-iron out of which the blanks are cut. These stops are longitudinally slotted, as shown at *d'*, and the hangers C being slotted at *e* at right angles to the slots *d'*, the said stops are both endwise and laterally adjustable, being secured by means of a set-screw, *e'*, extending upward through said slots *d' e*, and engaging nut *i* upon the upper sides of the hangers C, which, in order to prevent the said nut from turning, as well as to guide it during the lateral adjustment of the stops D, are upturned upon their edges, as shown at *f*, forming a channel and nut-locks. At the rear edges of the tables B B' are the supporting-ledges *g*, upon which are placed the stationary knives E E', that are secured to their respective tables B B' by means of screws. The cutting-edge of knife E is convex and slightly undercut or beveled, and that of knife E' concave, with a correspondingly undercut or beveled surface. At the rear end of the frame A are erected the uprights F, suitably braced together, and secured to the frame by means of a screw-bolt, *g'*, extending through a slot, *h*, cut in the side bar, *h'*, of the frame, and screwed into said uprights. The latter are braced to the frame by means of curved plates *g''* pivoted to the said uprights at one end, and at the other adjustably secured to the bar *h'* aforesaid by a set-screw, *l*, extending through a curved slot, *l'*, in said brace into the said bar.

L L' represent the cutter-holders carrying the movable cutters J J', and pivoted, to vibrate vertically, to the uprights F, the one above the other. The end bars, *j*, of these holders are connected together and maintained at a constant distance apart by means of the plates *p*, pivoted at their ends to the said bars.

The knife J is concave to correspond to the convexity of knife E, and knife J' convex to correspond to the concavity of the knife E', with which they respectively act. The movable

knives are received in L-shaped back plate, G, upon the free edge of the holders, being removably secured thereto by suitable screws, and are held against upward displacement thereby. These knives are actuated by a treadle, F', connected by a rigid rod, R, with the holders L L', and are raised after each stroke by the recoil of a spring, S, secured at one end to the treadle, and at the other to the frame A.

The sheets to be operated on are passed on the tables B B' against the stops D, and between the guides c, the former having been adjusted to the width of the blanks, and the latter to the width of the sheets, and the cutters brought down forcibly thereon. The sheet metal seized between the cutters is speedily and accurately divided and two blanks severed therefrom.

As the cutting-edges of the knives are worn away by successive sharpenings and long use, the movable ones are adjusted toward the fixed ones by loosening the screws g^1 aforesaid, and thrusting the uprights inward toward the said fixed knives until the knives are brought into proper relation to each other. I then reapply the said screws, and secure the adjustment thus obtained.

What I claim as new, and desire to secure by Letters Patent, is—

1. The combination, with the frame A, having tables B B', with laterally-adjustable guides c, of the hangers C, depending from the under

side of said table, and provided with a longitudinal slot, and the L-shaped stops D, having a longitudinal slot, and being endwise and laterally adjustable relative to said hangers, substantially as set forth.

2. The combination, with a table, B, having the laterally-adjustable transverse guides c, of the hanger C, channeled upon its upper side, and provided with a longitudinal slot, the stops D, having also a longitudinal slot, nuts seated in the channel of said hanger C, and set-screws extending through said slots and engaging the nuts, substantially as specified.

3. The combination, with the parallel tables B B', their ledges g, and the knives E E', seated on said ledges, of the parallel vertically-vibrating holders L L', their knives J J', connecting-plates p, a treadle, F', a rigid connecting-rod, R, and a spring, S, substantially as specified.

4. The combination, with a frame, A, having slot h, its parallel feed-tables B B', and cutters E E', of the uprights F, carrying the vibrating holders L L', the knives J J', slotted brace g^2 , and adjusting-screws g^1 , combined, arranged, and operating substantially as specified.

In testimony that I claim the above I have hereunto subscribed my name in the presence of two witnesses.

MALACHI BROWN.

Witnesses:

GEORGE B. BROOKS,

JOHN WELLER.