

G. H. COLLINS.  
Anti-Rattlers for Thill-Coupling.

No. 209,461.

Patented Oct. 29, 1878.

*Fig. 1*

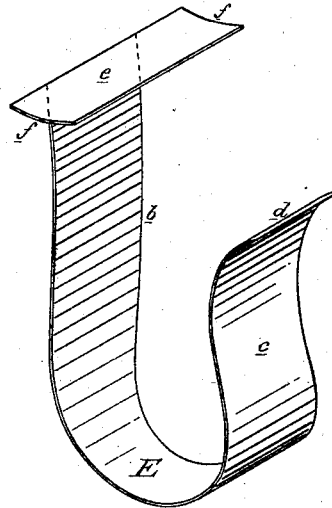

*Fig. 2*

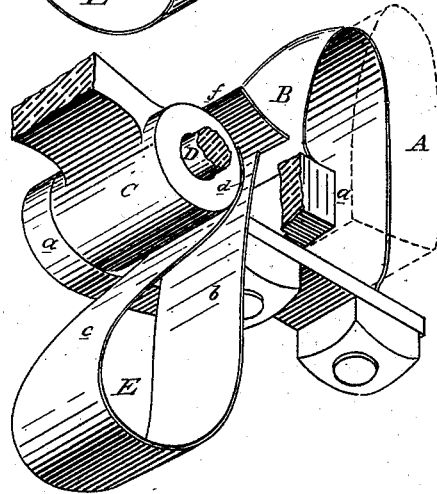

*Attest:*  
*A. Barthel*  
*Notary*

*Inventor:*  
*G. H. Collins*  
*By*  
*Notary*

# UNITED STATES PATENT OFFICE.

GILES H. COLLINS, OF WAYNE, MICHIGAN.

## IMPROVEMENT IN ANTI-RATTLERS FOR THILL-COUPINGS.

Specification forming part of Letters Patent No. 209,461, dated October 29, 1878; application filed July 22, 1878.

*To all whom it may concern:*

Be it known that I, GILES H. COLLINS, of the town and county of Wayne, and State of Michigan, have invented an Improvement in Anti-Rattlers for Thill-Couplings for Carriages, of which the following is a specification:

The nature of my invention relates to that class of devices employed to prevent noise or rattling in thill-couplings where the wear of the bolt in the coupling and the consequent noise arising therefrom in use are counteracted by holding the parts firmly together.

The invention consists in the peculiar construction of a removable metallic spring and its combination with the thill-coupling.

Figure 1 is a perspective view of the spring detached. Fig. 2 is a like view in operation.

In the accompanying drawings, which form a part of this specification, A represents a section of an axle; B, the clip secured thereto, and provided with the usual ears, *a*, to embrace the end C of the thill-iron, the clip and thill-iron being secured together by the bolt D, all of the above-named parts being of the construction and arrangement in ordinary and common use.

E is a spring, made of any spring metal, with a straight side, *b*, designed to rest against the front face of the clip, and between the ears thereof. A return-bend, *c*, at the bottom brings the front of said spring outwardly and upwardly, as shown, and terminates in an outward curve, *d*, which rests, when in use, against and partially upon the rear end of the thill-iron. The straight side *b* terminates in a flange, *e*, projecting nearly at right angles over the space between the two arms of the spring. This flange projects on either side beyond the width of the spring, forming bearings *f*, which,

when the spring is in place, rest upon the top of the ears of the clip and prevent its falling through.

In practice, this spring is inserted between the ears of the clip, (taking the place of the rubber block usually employed,) as shown in Fig. 2. The thill-iron is then inserted between the ears, compressing the spring until the curved front end is brought immediately under the front edge of the flange. The bolt is then inserted and the parts are held firmly together, and the pressure of the spring preventing the rattling of the parts.

I am aware that a doubled leaf-spring has before been used to prevent rattling of the thill-coupling, and has been inserted between the rear end of the thill and the clip, the same being shown in patent granted October 3, 1876, to John C. Hendry; but Hendry's spring, being of less width than the space between the ears of the clip, and being held by a narrow rearwardly-turned flange, will in use work down and jam between the thill and the clip, while my spring, by having arms which rest upon the ears of the clip, is always held in its proper position.

What I claim as my invention, and desire to secure by Letters Patent, is—

The leaf-spring E, for the purpose set forth, the rear bend, *b*, of which is provided with a forwardly-projecting flange, *e*, having ends *f*, extending beyond the sides of the spring, to rest upon the ears of the clip, constructed and arranged substantially as described and shown.

GILES H. COLLINS.

Witnesses:

H. S. SPRAGUE,  
C. H. S. HART.