

I. WHITBECK.
Desk.

No. 209,533.

Patented Oct. 29, 1878.

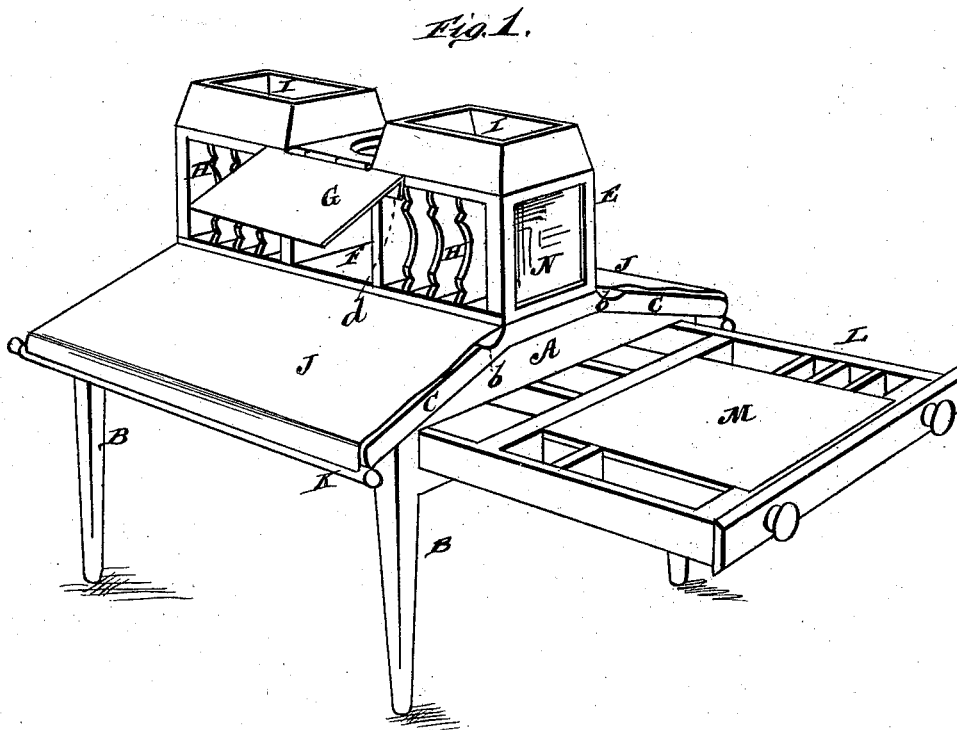

WITNESSES
Robert Evans
James J. Sheehy

INVENTOR.
Isaac Whitbeck.
Gilmore, Smith & Co.
ATTORNEYS.

I. WHITBECK.
Desk.

No. 209,533.

Patented Oct. 29, 1878.

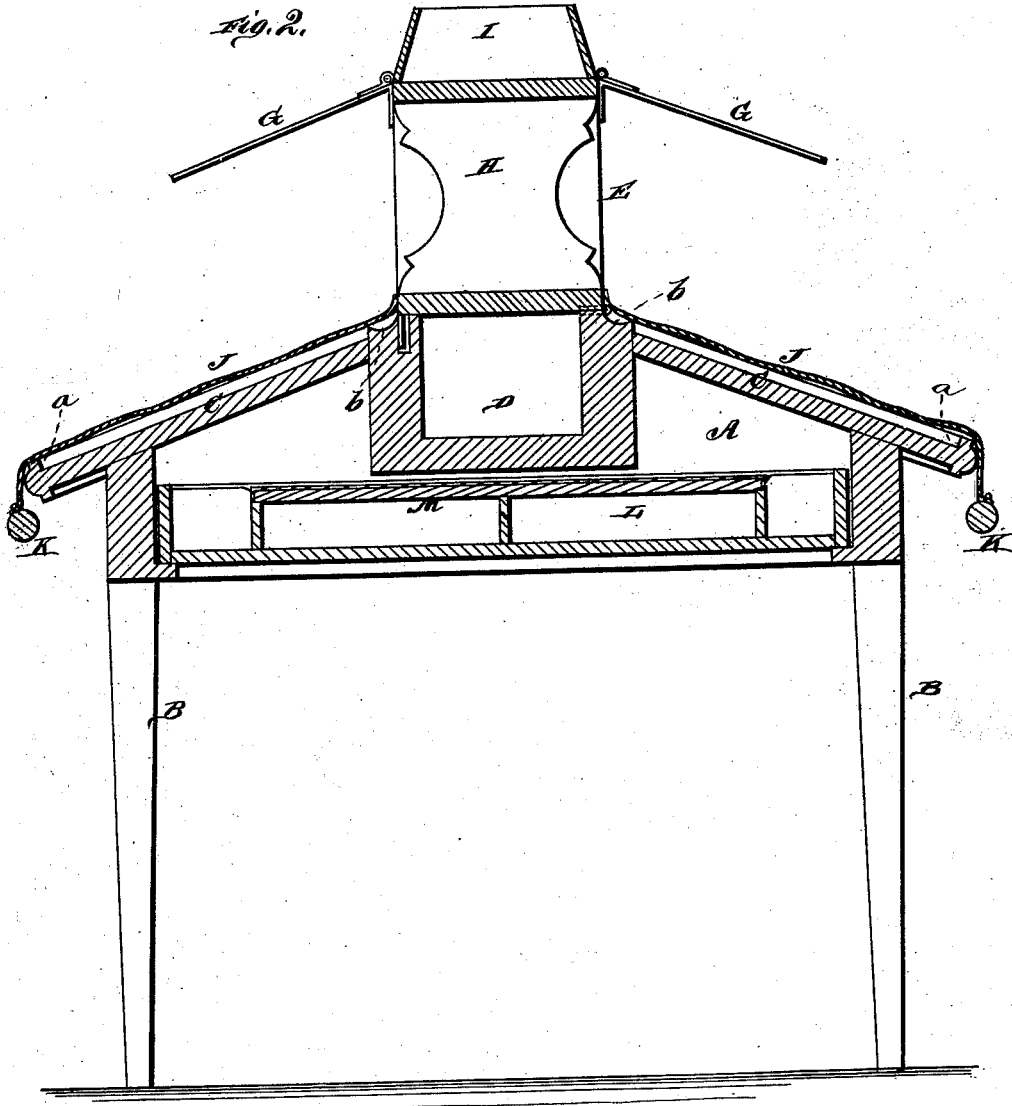

WITNESSES
Robert Emmett
James J. Sheehy

INVENTOR.
Iraac Whitbeck
Fillmore Smith & Co.
 ATTORNEYS

UNITED STATES PATENT OFFICE.

ISAAC WHITBECK, OF POTTER, NEW YORK.

IMPROVEMENT IN DESKS.

Specification forming part of Letters Patent No. **209,533**, dated October 29, 1878; application filed March 23, 1878.

To all whom it may concern:

Be it known that I, ISAAC WHITBECK, of Potter, in the county of Yates and State of New York, have invented a new and valuable Improvement in Desks; and I do hereby declare that the following is a full, clear, and exact description of the construction and operation of the same, reference being had to the annexed drawings, making a part of this specification, and to the letters and figures of reference marked thereon.

Figure 1 of the drawings is a representation of a perspective view of my desk, and Fig. 2 is a transverse vertical section of the same.

The nature of my invention consists in the construction and arrangement of a reading and writing desk, as will be hereinafter more fully set forth.

The annexed drawing, to which reference is made, fully illustrates my invention.

A represents the frame of my improved desk, supported upon four legs, B B, and provided, on opposite sides, with the inclined stops C C. These are at their edges provided with moldings *a a*, extending above the upper surface, so as to prevent books, &c., from being accidentally shoved off and falling on the floor.

In the center, between the two desk-tops, is a box, D, extending the entire length of the desk, which is intended for private papers, such as are not in general use; and this box is covered by a frame, E, which is hinged on one side, and intended to be fastened by a secret lock or other fastening. In the center of the frame E is a receptacle, F, for a lamp, and above this receptacle are hinged two reflectors, G G, which are provided with flanges *d*, to form stops, so that when the reflectors G G are turned down as far as said stops will admit, they will be in proper position to reflect the light down upon the books laid on the desk-tops C C. When not desired to be used, either one or both of the reflectors may be turned upward out of the way.

On each side of the lamp-receptacle F are suitable compartments H H for books, and on

top of the frame are two boxes, I I, which may be used, one for holding combs, brushes, and similar articles, and the others for scissors, needles, threads, and other sewing materials.

To each side of the frame is permanently attached a curtain or flexible cover, J, to lie over the tops C C, said covers having a round stick, K, attached to the outer edge, so that the cover may be rolled up and laid in a recess formed at the upper end of the top C, as shown at *b*.

This desk is intended to be placed with one end opposite a window or between two windows, so that the light will fall upon the two desk tops C C. In the opposite end, in the main frame A, is a drawer, L, which is used for writing purposes, it being divided into suitable compartments for paper, envelopes, newspapers, pens, inkstands, &c., and has also a removable desk-top, M, covering some of said compartments. At this end of the desk the frame E is provided with a mirror, N, as shown.

What I claim as new, and desire to secure by Letters Patent, is—

1. In a desk, the recessed tops C C, provided with the permanently-attached flexible covers J J, having the sticks K K secured to their outer ends, for the purposes set forth.

2. In a desk, the combination of the tops C C, the central box D between the same, and the hinged frame E, for covering said box, as herein set forth.

3. The hinged frame E, provided with lamp-receptacle F, book-compartments H H, and boxes I I, in combination with the desks having tops C C and central box D, for the purposes herein set forth.

In testimony that I claim the above I have hereunto subscribed my name in the presence of two witnesses.

ISAAC WHITBECK.

Witnesses:

CHAS. G. JUDD,
ANDREW C. HARWICK.