

A. G. McBRAYER & F. G. THOMAS.
Churn.

No. 209,767.

Patented Nov. 12, 1878.

FIG 1

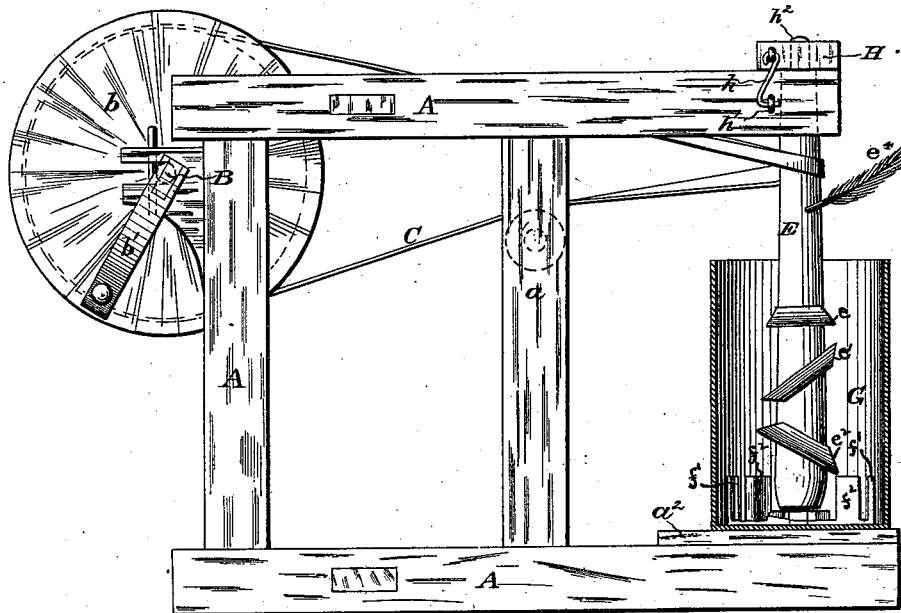

FIG 2

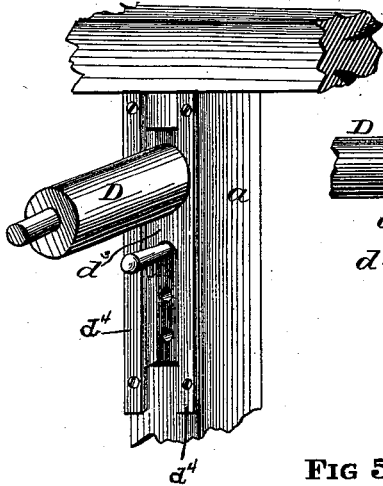

FIG 3

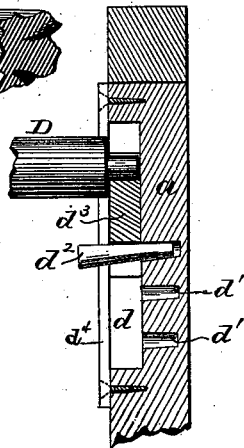

FIG 5

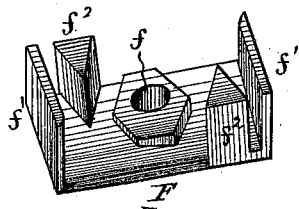
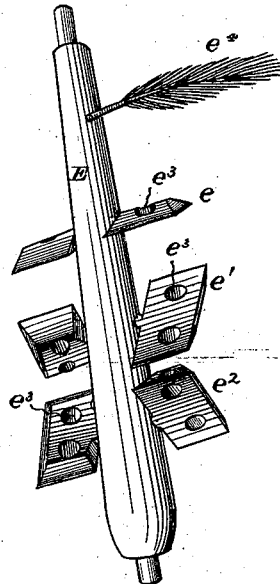

FIG 4



WITNESSES
Wilmer Bradford,
J. Berthong.

Austen G. McBrayer,
Franklin G. Thomas.
INVENTORS
per Redson Brothers
Attorneys.

UNITED STATES PATENT OFFICE.

AUSTEN G. McBRAYER AND FRANKLIN G. THOMAS, OF SHANNON, MISS.

IMPROVEMENT IN CHURNS.

Specification forming part of Letters Patent No. **209,767**, dated November 12, 1878; application filed June 21, 1878.

To all whom it may concern:

Be it known that we, AUSTEN G. McBRAYER and FRANKLIN G. THOMAS, of Shannon, in the county of Lee and State of Mississippi, have invented certain new and useful Improvements in Churns; and we do hereby declare that the following is a full, clear, and exact description thereof, which will enable others skilled in the art to which it appertains to make and use the same, reference being had to the accompanying drawings, and to letters of reference marked thereon, which form a part of this specification, and in which—

Figure 1 is a side view of our improved churn. Figs. 2 and 3 are detached views of the adjustable bearings or guides for the idler or tension wheel. Fig. 4 is a perspective view of the dasher, and Fig. 5 is a similar view of the ink or dasher-socket.

Corresponding parts in the several figures are denoted by similar letters of reference.

This invention relates to improvements in churns; and consists of the combination of parts, as hereinafter more fully described and claimed.

In the annexed drawing, A refers to a frame, preferably of an oblong shape, to the upper part, at one end, of which is journaled a shaft, B, carrying a pulley-wheel, *b*, and a crank or handle, *b'*. The wheel *b* carries a belt, C, which passes over the idler or tension wheel D, and encircles the upper part of the dasher E. The uprights *a* of the frame A are provided upon their inner surfaces with a slot or groove, *d*, having holes *d'* for the reception of a pin, *d''*. A flat oblong block, *d'''*, having its ends concaved, is held within the groove *d* by means of the slats *d⁴*. In the upper concavities of the block *d'''* rests the tension-wheel D. The dasher E is provided with three or more sets of wings or arms, *e e' e''*, set at different angles to each other, and of a rectangular shape, flat on one side and slightly rounding off or oval on the other, and provided with holes *e³ e^{3'}*, through which, in churning, the cream passes. F marks an ink or socket, which is placed in the bottom of the churn or receptacle G, having a hole, *f*, for the reception of the lower end of the dasher E. This socket is provided with end pieces *f¹ f^{1'}*, arranged at right angles to the bottom, and also two triangular pieces or uprights, *f² f^{2'}*, placed a lit-

tle distance from the end pieces and diagonally opposite each other. These uprights *f² f^{2'}* are placed with one of their sides even with the edge of the bottom, thus presenting inwardly a sharp edge or angle. The upper part of the dasher E is furnished with a brush or feather, *e⁴*, to drive away flies and other insects from the mouth of the receptacle or churn G. To the upper end of the frame A, opposite to the fly-wheel *b*, is a hinged cap, H, which is held down or fastened by the hook and staple *h h'*. In this cap H is a hole, *h²*, which receives and holds the upper end of the dasher-shaft. The bottom part of the frame A is provided with a platform, *a²*, to furnish a support or base for the tub or churn G.

It will be seen that as motion is communicated to the dasher by means of the pulley *b* and belt *c*, the lower set of wings, *e²*, force the cream downwardly, which passes through the socket F, and is cut or divided by the uprights *f² f^{2'}*. The middle set, *e¹*, forces the cream upwardly, and the upper set, *e*, cutting the cream horizontally, forces it neither upwardly nor downwardly. A portion of the cream passes through the holes *e³ e^{3'}* made in the arms.

By these means the cream is thoroughly broken up and the process of churning easily and speedily accomplished.

Having thus described our invention, what we claim, and desire to secure by Letters Patent, is—

1. In a churn, the dasher E, provided with the three sets of perforated arms *e e' e''*, the first set being arranged at right angles and the latter two at oblique angles to the longitudinal axis of the said dasher E, substantially as and for the purpose set forth.

2. In combination with the dasher E, provided with the sets of wings *e e' e''*, of the ink or socket F, having the end pieces *f¹ f^{1'}* and triangular-shaped uprights *f² f^{2'}*, substantially as and for the purpose set forth.

In testimony that we claim the foregoing as our own we hereunto affix our signatures in presence of two witnesses.

A. G. McBRAYER,
F. G. THOMAS.

Witnesses:

A. L. POLLARD,
R. H. ROBERTSON.