

O. PEDERSON.
Screw-Cutting Die.

No. 209,774.

Patented Nov. 12, 1878.

Fig 1

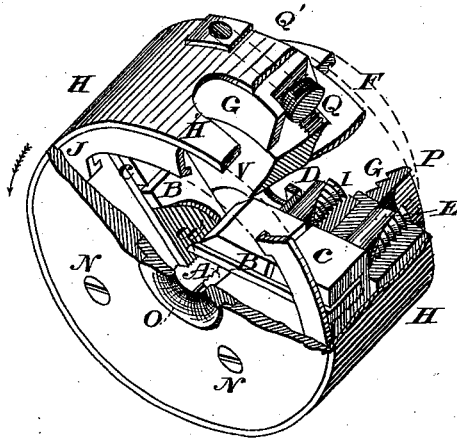

Fig 3

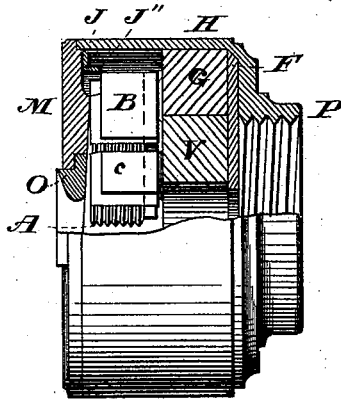
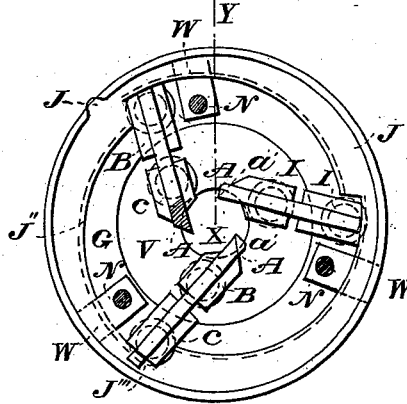

Fig 2



Witnesses:

Rolph D. Larson
Hugh H. Mason

Inventor:

Ole Pederson
Per F. H. Treach, atty.

UNITED STATES PATENT OFFICE.

OLE PEDERSON, OF JOLIET, ILLINOIS.

IMPROVEMENT IN SCREW-CUTTING DIES.

Specification forming part of Letters Patent No. 209,774, dated November 12, 1878; application filed April 8, 1878.

To all whom it may concern:

Be it known that I, OLE PEDERSON, of the city of Joliet, county of Will, and State of Illinois, have invented a new and useful Improvement in a Turning and Screw-Cutting Chuck or Cutter-Head, which improvement is fully set forth in the following specification and accompanying drawing, in which—

Figure 1 is a perspective view of my chuck, having parts broken away to show its internal arrangement; Fig. 2, a front view of the same with cover removed; Fig. 3, a partial sectional view taken upon line *x y*.

My invention relates to that class of chucks or cutter-heads in which the bar or shaft to be turned or threaded is held stationary upon its own axis while said chuck, containing three tools having their cutting-edges formed by beveling one of their ends on one side to an angle of about sixty degrees with the other, which side is placed next to and in a plane nearly tangent to the article being turned or threaded, revolves upon a shaft or mandrel, operating upon it (the work) as it is fed through.

The object of my invention is to furnish a device by which to quickly and accurately adjust the aforesaid cutting-tools, whereby their same relative position to the work is maintained, whether it be great or small. This fact enables me to use a tool having the angle of its cutting-edge much more acute than is usually the case without fear of its being destroyed when the diameter of the work has been changed. The friction of the cuttings upon the edge of tool is much reduced, causing so little heat to be generated therefrom as to make the use of oil or other lubricant unnecessary and an exceedingly high rate of cutting speed possible and safe, thereby very materially reducing the expense of these operations.

My invention consists in setting the cutters A A A each in the two pivoted saddles or carriers B and C, the pivots D and E of said saddles having bearing in the sleeve-adjusting screws I I, set respectively in the two concentric rings G and V. The outer one, G, is attached to the outer shell, H, which revolves upon a shaft or mandrel, connection being made by the female screw P. The ring V is given a slight rotary movement within G by means of the worm-gear Q, actuated by a key

or socket-wrench inserted in hole Q'. This movement, by increasing or diminishing the angle of cutters from a line drawn from center of chuck passing through center of pivots E, correspondingly increases or diminishes the distance of the edges of cutters from said center of chuck. This manner of adjustment possesses the advantage of maintaining the same relative position of cutters and work, whether it be great or small.

As the cutters become shortened by continued resharpening, they are set forward by the cam-ring J, which is shifted by the lug J', projecting through a slot in edge of shell H. J'' is a flange upon inner edge of said ring, that, by engaging with notch J''' in the cutters, keeps them from moving forward out of their places.

M is the cover of chuck, the back of which is made slightly conically concave—about one and a half degrees—so that when the cutters are tightly pressed against it by the sleeve-screws I I a slight lead or clearance is given the lip *a'* of cutters.

H' is one of three openings cut in outside shell, allowing cuttings to escape. W W W are lugs projecting from inside of outside shell, into which are inserted screws N N N, for holding on cover.

It will be evident from the foregoing that although the work is held stationary and the chuck revolved about it, the same result will be obtained if the chuck is held stationary upon its axis, as if attached to the slide-rest of a lathe, and the work revolved in the ordinary manner.

Having thus described my invention, what I claim as new and original, and desire to secure by Letters Patent, is—

1. The cutters and saddles or carriers B and C, and pivots D and E, in combination with concentric rings G and V, worm-gear Q, cam-ring J, shell H, and diaphragm F, for the purposes and in the manner substantially as shown and described.

2. The cover M, with concave back, in combination with cutters and sleeve-screws I I, for the purposes and in the manner substantially as shown and described.

OLE PEDERSON. [L. S.]

Witnesses:

F. H. TREAT,
CHARLES WILLIAM STAEBLE.