

A. NAWADNY.  
Machine for Boring Brush-Blocks.

No. 209,828.

Patented Nov. 12, 1878.

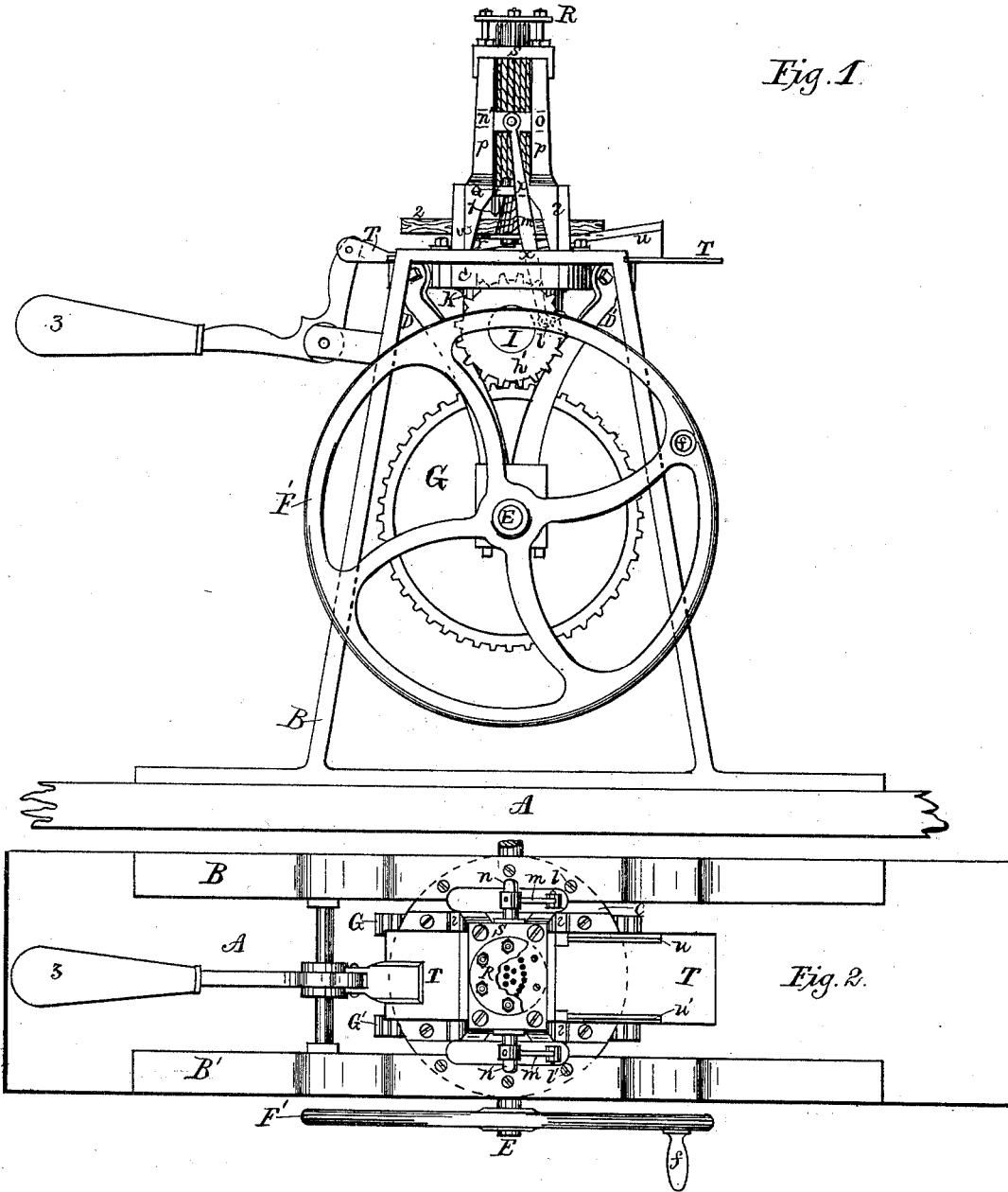

Witnesses:  
*J. W. Burnham.*  
*Am. Cr. Co. Inters.*

Inventor:  
*Albert Nawadny*  
by  
*W. H. Babcock*

A. NAWADNY.  
Machine for Boring Brush-Blocks.

No. 209,828.

Patented Nov. 12, 1878.

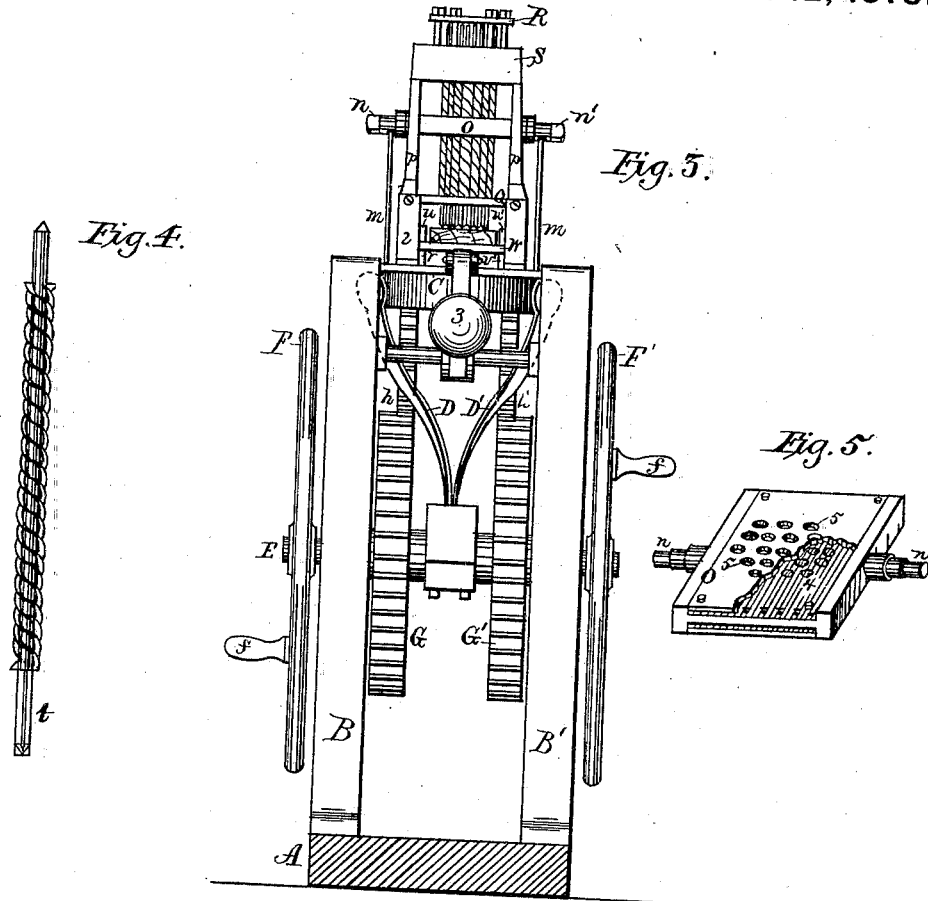

Witnesses:  
*F. M. Dunham*  
*Wm. C. W. Smith*

Inventor:  
 Albert Nawadny  
 by  
 W. H. Babcock  
 Attorney.

# UNITED STATES PATENT OFFICE.

ALBERT NAWADNY, OF NEW ORLEANS, LOUISIANA.

## IMPROVEMENT IN MACHINES FOR BORING BRUSH-BLOCKS.

Specification forming part of Letters Patent No. 209,828, dated November 12, 1878; application filed October 15, 1878.

*To all whom it may concern:*

Be it known that I, ALBERT NAWADNY, a resident of the city of New Orleans, parish of Orleans, and State of Louisiana, have invented a certain new and useful Improvement in Machines for Drilling Brush-Blocks, &c.; and I do hereby declare the following to be a full, clear, and correct description of the same, reference being had to the annexed drawing, making a part of this specification.

This invention relates to a simple mechanical machine whereby any desired number of holes may be drilled in close proximity to one another, and hence it is more especially adapted to the drilling of brush-backs, &c.

The nature of the invention will be readily understood by referring to the accompanying drawing, whereon—

Figure 1 represents a side elevation; Fig. 2, a top or plan view; and Fig. 3, Plate 2, a front elevation. Part of the figures are broken away, in order to better exhibit important features in the invention. Fig. 4 represents a detached spindle and drill; and Fig. 5, a view of the follower or driving-plate.

Like all other mechanical machines, this may be readily adapted to be run either by steam or hand power. The latter plan is shown in the drawing, whereon A represents the foundation, on top of which is securely bolted, at a suitable distance apart, a pair of stands, B B', for supporting a bed-plate, C, and hangers D D'. In the lower end of the latter is fitted the main or driving shaft E, on the outer ends of which are keyed or otherwise secured the driving or fly wheels F F', each provided with a handle, as shown at *f f'*. On the main-shaft is also secured, between the hangers, a pair of cog-wheels, G G', which engage pinions *h h'*, that are secured on the outer ends of a shaft, I, which passes through and operates in a lug, K, the latter secured or cast on the under side of the bed-plate C. The aforesaid parts B B', D D', F F', and *h h'* form no part of my invention, as any other suitable supporting and actuating devices may be substituted therefor.

On the outer side of each of the above-mentioned pinions is a pin, *l l'*, on which are fitted the lower ends of a pair of connecting-rods, *m m'*, the upper ends of which operate on pins

*n n'* that project outward from the sides of the driving plate or follower, O, the latter operating between the uprights P of a frame, Q, which has its legs *r* securely bolted to the bed-plate C. A cap, R, is bolted over the top *s* of the uprights, and serves as a bearing-plate for the upper ends of the drill-spindles.

The spiral portions of the aforesaid spindles are made of equal lengths, the drill portions and upper ends being made of a somewhat reduced diameter, so as to form shoulders, which play against the under side of the top *s* and upper surface of the frame Q, thereby preventing any endwise motion of the same. The upper ends of the drill-spindles pass through the top *s*, and their pointed ends operate against the under side of the bearing plate or cap R, which lessens the friction on the spindles and relieves the top *s* from any excessive wear. The drill proper is made with double vertical cutting-edges, and is either cut at the lower end of the spindles, as shown at *t*, or made separate and secured thereto by any known means.

Upon the bed-plate C is a sliding plate, T, which is operated back and forth within the frame Q. This plate is provided with raised wedge-shaped sides, as at *u u'*, and upon these sides rest the reverse wedges *v v'* of a horizontal drill-table, W, having projecting lugs, so as to operate on the vertical guide-rods *x*. These rods are incased by springs, as shown at 1, which have a tendency to press the table downward upon its wedge-supports.

The block to be drilled is laid upon the table and passed under the drills, as shown at 2. The drills being in motion, the said block is fed toward them by pulling outward the handle 3 and its connecting plate, which movement causes the wedges of the latter to press the table upward. On releasing the lever the action of the springs 1 will cause the table, with its block, to be pressed downward from the drills.

That portion of the driving plate or follower through which the drills pass is formed of three thicknesses of metal. The central one, 4, being made of steel, is tapped or cut to fit the spiral portion of the drill-spindles, and it is by the motion of this follower that the said spindles are operated. The outer plates of the follower

are provided with holes 5, drilled to the diameter of the spindles, and serve to prevent the latter from springing or buckling.

Having described my invention, what I claim as new, and desire to secure by Letters Patent, is—

1. In a drilling-machine, the combination of a series of drills having spiral spindles, all of which are arranged to be operated by the forward and backward movement of a follower, O, having an inner plate, 4, furnished with spiral holes, as described, and for the purpose set forth.

2. A drilling-machine composed of a bed-

plate, C, upon which is mounted a frame, Q, having a cap, R, for receiving the upward pressure of the drills when the latter are put in motion through the action of the follower O, to which power is transmitted through connecting-rods *m m'* and pinions *h h'*, the latter being in gear with cog-wheels that are secured upon a driving-shaft for the said purpose.

In testimony whereof I have hereunto signed my name.

ALBERT NAWADNY.

In presence of—

J. C. HUBBELL,  
P. J. FINNEY.