

J. COOK.
Wind-Engine.

No. 209,862.

Patented Nov. 12, 1878.

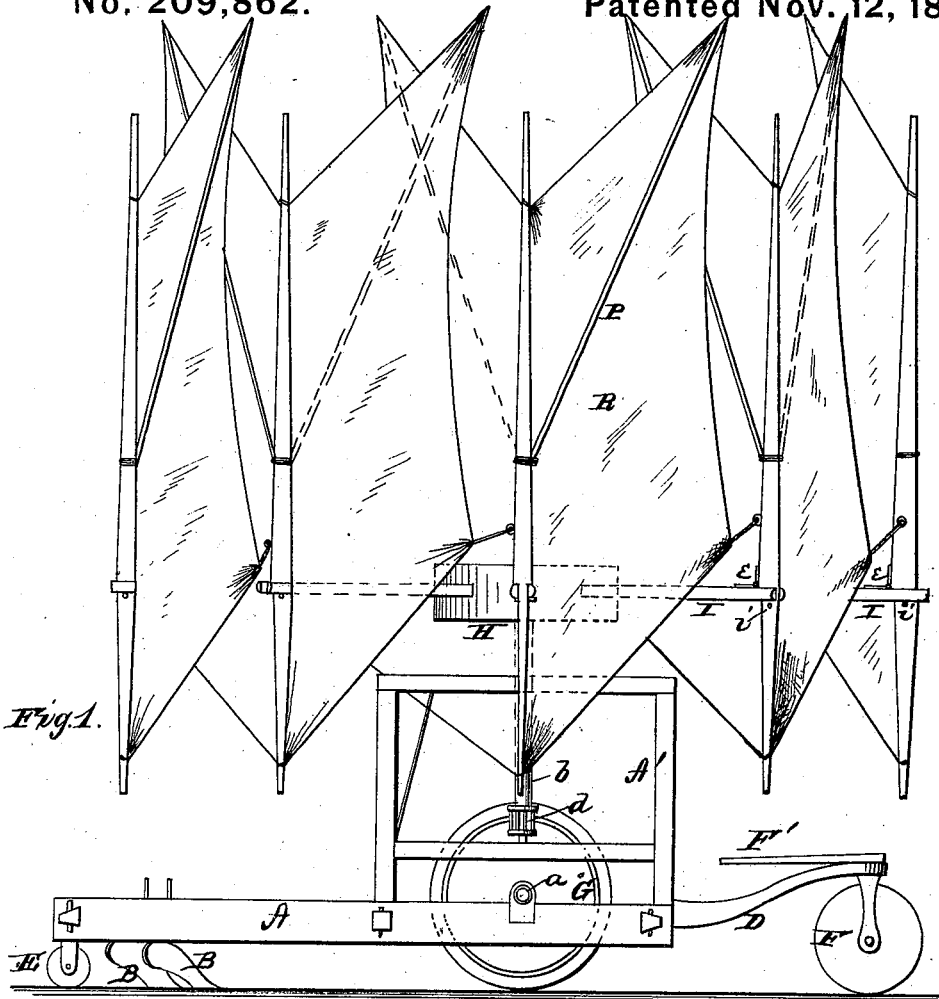

Fig. 1.

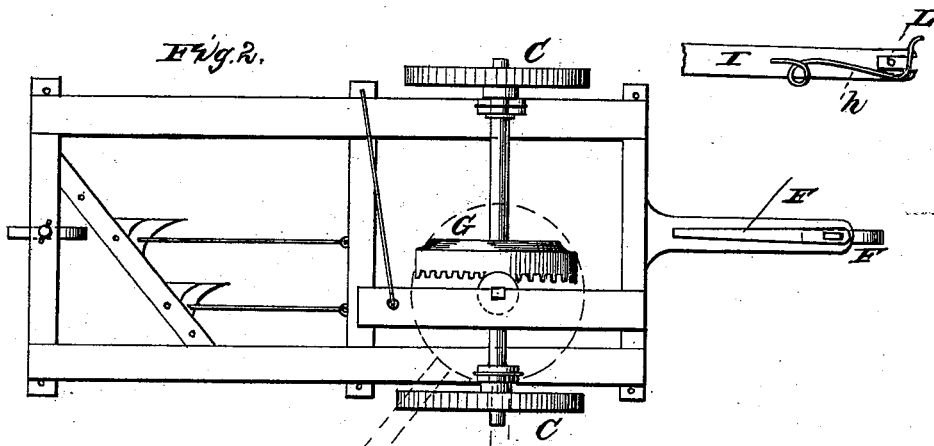

Fig. 2.

WITNESSES
A. L. Curand
Frank Galt

By

INVENTOR
John Cook
Alexander Mator
Attorneys

UNITED STATES PATENT OFFICE.

JOHN COOK, OF KIRKWOOD, ILLINOIS.

IMPROVEMENT IN WIND-ENGINES.

Specification forming part of Letters Patent No. **209,862**, dated November 12, 1878; application filed May 29, 1878.

To all whom it may concern:

Be it known that I, JOHN COOK, of Kirkwood, in the county of Warren, and in the State of Illinois, have invented certain new and useful Improvements in Wind-Powers or Wind-Wheels; and do hereby declare that the following is a full, clear, and exact description thereof, reference being had to the accompanying drawings, and to the letters of reference marked thereon, making a part of this specification.

The nature of my invention consists in the construction and arrangement of a wind-power for stationary or moving machinery and other purposes, as will be hereinafter more fully set forth.

In order to enable others skilled in the art to which my invention appertains to make and use the same, I will now proceed to describe its construction and operation, referring to the annexed drawings, in which—

Figure 1 is a side elevation of my wind-power, showing the same applied to a plow. Fig. 2 is a plan view of the same with the wind-wheel removed.

A represents a frame of any suitable dimensions, to which one or more plows, B, are connected in any convenient manner, so as to be raised and lowered, as required.

The frame A is supported upon two main wheels, C C, secured on an axle, *a*, a rear center wheel, E, and a center wheel, F, in front. This latter wheel is swiveled in the front end of an arm, D, which projects from the frame, and the swivel provided with a lever, F', by means of which the wheel is turned to the right or left for guiding the machine.

On the main frame A is erected a suitable upright frame, A', in which a vertical shaft, *b*, has its bearings. This shaft is, near its lower end, provided with a pinion, *d*, which meshes with a gear-wheel, G, on the axle *a*, as shown.

On the vertical shaft *b* is secured a hub, H, from which radiate a series of arms, I I, the outer end of each arm being slotted or forked to receive a mast, L, hinged thereto and ex-

tending any suitable distance above and below the arm. The hinges *e e*, which connect the masts L to the arms I, are so arranged that the masts can be thrown down inward, and when said masts are raised in a vertical position they are held either by means of pins *i* or spring-catches *h*, or any other suitable fastenings.

Each mast L is provided with a spar, P, and sail R, as shown, and the sail connected at the lower corner to the mast in front of it. This arrangement of mast and sails constitutes the wind-wheel, and as the same is in motion it rotates the center shaft, *b*, and, through the gearing *d G*, communicates motion to the axle *a*. The wheels C C being fast on said axle, it follows that the machine is propelled forward.

The masts to which the sails are connected being hinged in the outer ends of the radial arm, any desired number of such masts and sails may be used, the remaining masts being thrown down horizontally, and thus the speed of the wind-wheel easily regulated, as required.

My invention may be attached to any stationary machinery, such as mills, pumps, thrashing-machines, &c., or to movable machinery—for instance, plows, mowers, road-wagons, &c.; and it may also be used for navigating vessels.

Having thus fully described my invention, what I claim as new, and desire to secure by Letters Patent, is—

The combination of a vertical shaft connected by gearing or otherwise with machinery to be driven, a hub with a series of horizontal radiating arms secured to said shaft, and a series of masts provided with sails and hinged in the outer ends of the arms, substantially as and for the purposes herein set forth.

In testimony that I claim the foregoing I have hereunto set my hand this 13th day of May, 1878.

JOHN COOK.

Witnesses:

JOSHUA RYDER,
A. N. SMITH.