

S. MOCK.

Automatic Clearer for Spinning-Mule.

No. 209,912.

Patented Nov. 12, 1878.

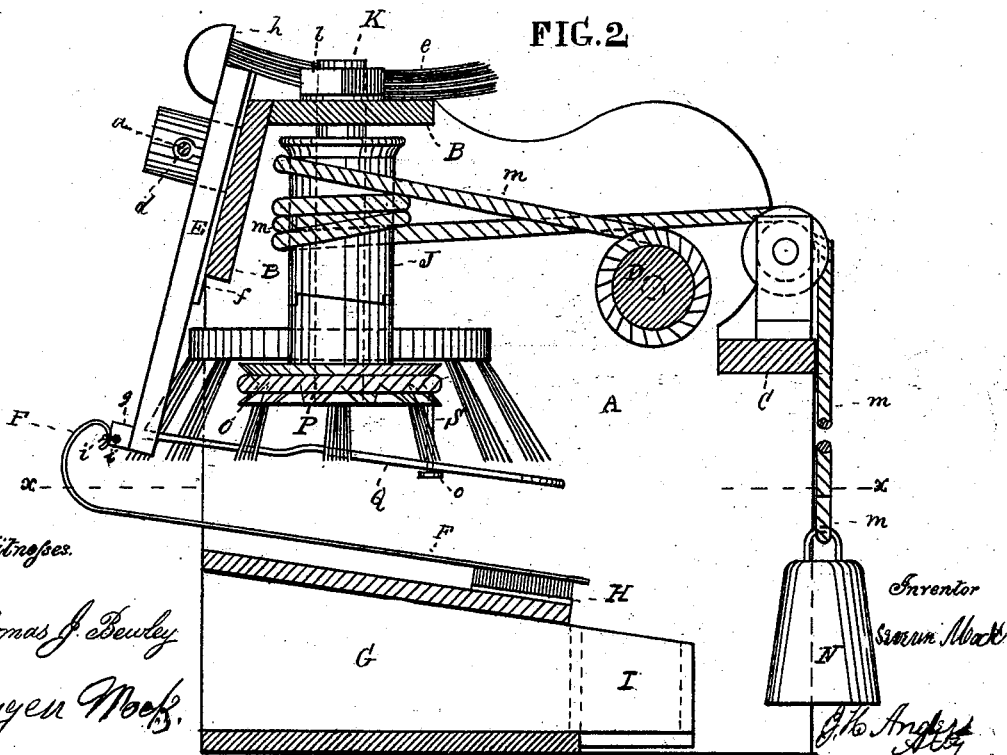
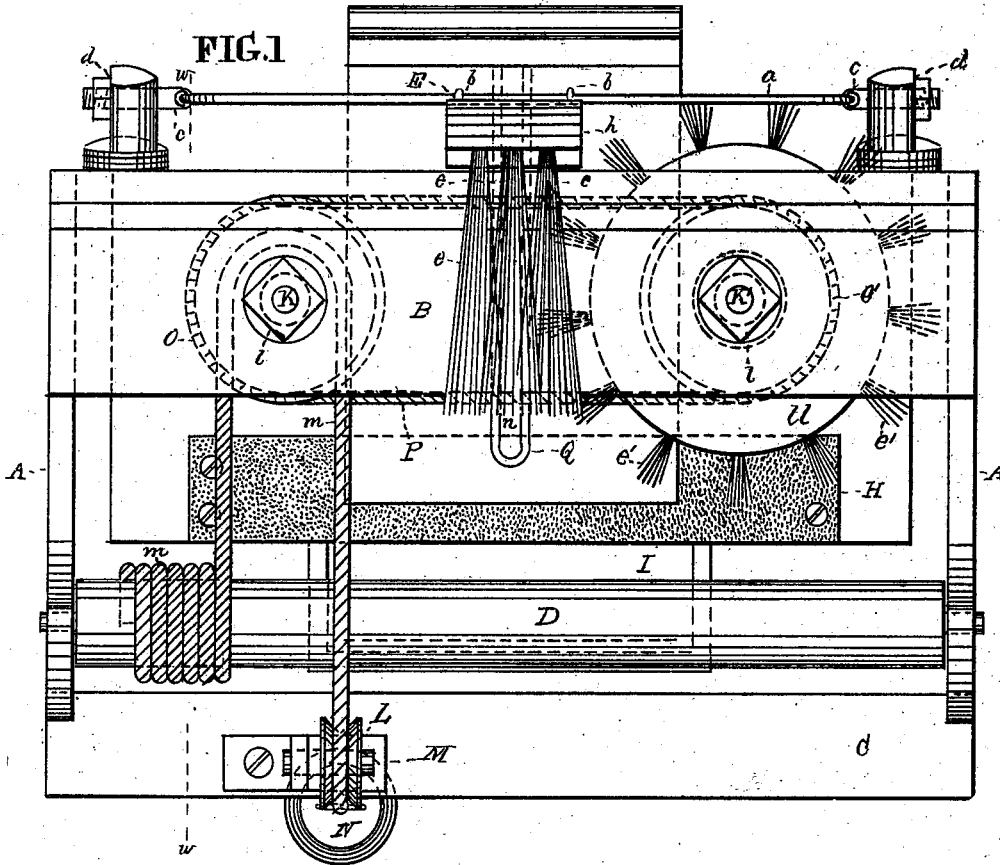

Witnesses
 Thomas J. Bewley
 Eugen Mock.

Inventor
 Simon Mock

J. H. Anderson
 Atty

S. MOCK.
Automatic Clearer for Spinning-Mule.
No. 209,912. Patented Nov. 12, 1878.

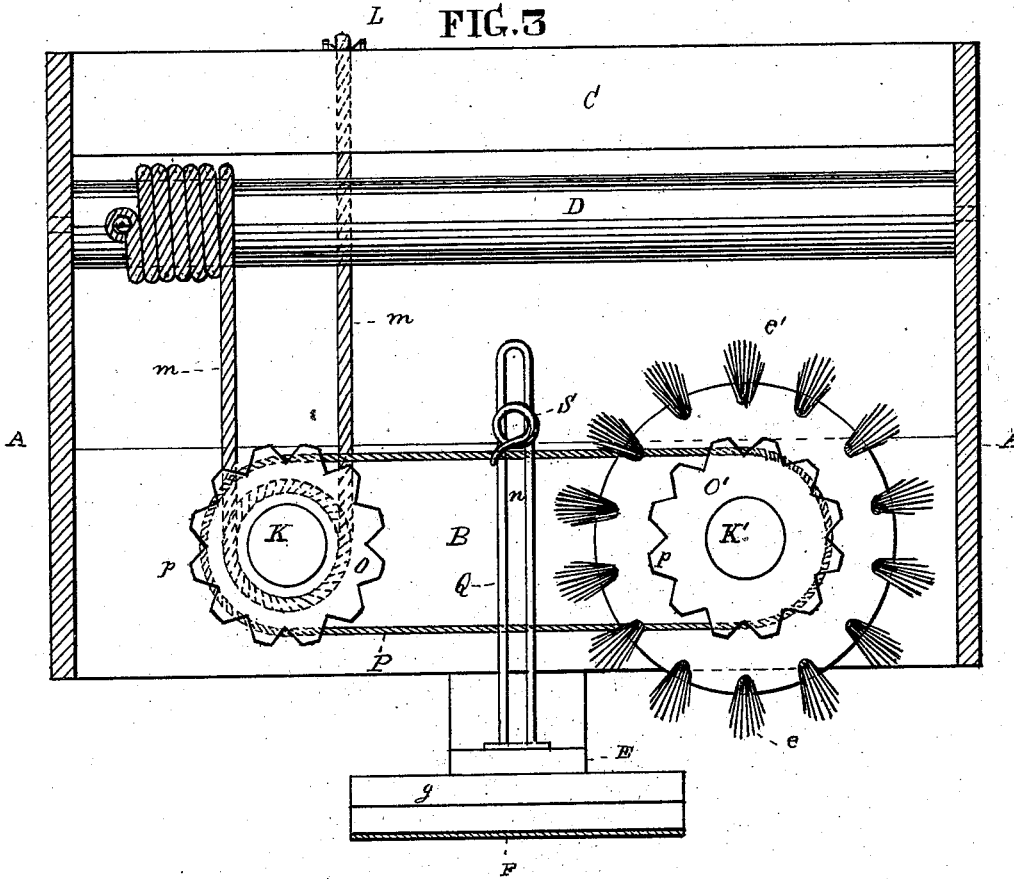

Witnesses

Thomas J. Dewley.

Ernest Mock

Inventor.

Severin Mock

J. H. Anderson
Att'y

UNITED STATES PATENT OFFICE.

SEVERIN MOCK, OF PHILADELPHIA, PENNSYLVANIA.

IMPROVEMENT IN AUTOMATIC CLEARERS FOR SPINNING-MULES.

Specification forming part of Letters Patent No. **209,912**, dated November 12, 1878; application filed July 5, 1878.

To all whom it may concern:

Be it known that I, SEVERIN MOCK, of the city and county of Philadelphia, and State of Pennsylvania, have invented a new and useful Improvement in Automatic Clearers for Spinning-Mules, of which the following is a specification:

This invention is an improvement on a like invention for which Letters Patent were granted to me on the 29th day of December, 1874, and numbered 158,218, which invention consists of a reciprocating slide provided with a brush for clearing the upper side of the roller-beam, and plush pads for clearing the front of the same at its upper end, and at its lower end it is provided with a blanket-apron for clearing the mule-carriage board, the slide receiving its reciprocating movement from end to end of the mule by means of its connection with an endless belt passing over grooved pulleys near the ends of the mule motion being given thereto by the movement of the back-shaft by means of an endless band, which is passed several times around the back-shaft, and in the same manner around a drum to which one of the pulleys is attached.

In my present invention the tufts of bristles for clearing the upper side of the roller-beam are set in a block, which is secured to the front of the reciprocating slide, so as to form a rabbet at the upper end of the slide, to clear the steel roller stands on the upper side of the roller-beam as the slide passes them; and the lower end of the slide is provided with a longitudinal wire in front, to bring the apron far enough in front of the slide to clear the carriage-board at the rear of the spindles; and instead of having an endless band for connecting the drum above mentioned with the back-shaft, I attach one end of a cord to the shaft, and, after passing it several times around the shaft and in the same manner around the drum, pass its free end over a pulley, and provide it with a weight for keeping it always tight upon the shaft and drum, to prevent its sagging.

Another feature of this invention is the employment of a revolving brush for clearing the band that actuates the brush-slide, which is fully described hereinafter.

Figure 1 is a plan view of part of the frame

of a spinning-mule having my improvements attached. Fig. 2 is a vertical section at the broken line *w w* of Fig. 1. Fig. 3, Sheet No. 2, is a bottom view taken at the broken line *x x* of Fig. 2.

Like letters of reference in all the figures indicate the same parts.

A is the standing frame of a spinning-mule, having the ordinary roller-beam B, reel-board C, and back-shaft D. E is a reciprocating slide, which moves on the wire *a* by means of the eyebolts *b b*, which project from its front side, the wire being secured in the heads of the screw-bolts *d d*, and drawn tight by means of the screw eyebolts *c c*, with which its ends are connected. The bolts *d d* pass through the front of the roller-beam B, and are secured by means of nuts inside of the same. The upper end of the slide is provided with the brush-block *h*, which has tufts of bristles *e e e*, for clearing the upper side of the roller-beam. The block *h* is confined to the front of the slide E, so as to form a rabbet or offset to clear the steel roller stands in the movement of the slide backward and forward. The rear side of the slide, at its upper end, has strips, *f*, of felt or other suitable material, for clearing the front of the roller-beam. To the strip *g*, on the lower end of the slide E, is attached the front end of the blanket-apron F, for clearing the carriage-board G as it passes under the apron. The card H, for clearing the apron, as well as the tufts of bristles *e* and felt strips *f*, are shown in my patent above referred to, and hence a particular description is deemed unnecessary in this place. The mode of making the brush-block *h* separate from the slide to form an offset is a new and important feature of this invention, as it secures a free movement of the upper end of the slide, as above described.

I is a box for receiving the clearings from the card H. The strip *g*, to which the apron F is attached, is provided with the longitudinal wire *i*, which has elbows *i' i'* connected with it, of sufficient length to bring it far enough in front to cause the apron to sweep the carriage-board clear to the spindles.

In the drawings the front of the roller-beam B is represented on an angle, according to the modern make of the mules.

The machinery for giving the reciprocating movements to the slide E is mainly like that contained in my patent above referred to, and is as follows: The drum J on the perpendicular stud K (the upper end of which is passed through the roller-beam B, and firmly secured by means of the nut l) has connection with the back-shaft D by means of the cord m, one end of which is attached to the back-shaft, and several turns around the shaft given to the cord, and also around the drum J. The cord is then passed over the grooved pulley L in the standard M, which is fastened to the upper side of the reel-board C. To this end of the cord the weight N is attached, whereby the cord is at all times kept tight upon the drum and back-shaft, and not liable to sag. On the lower end of the stud-shaft K is a grooved pulley, O, and on the like shaft K', at the other end of the mule, a like pulley, O', and around the pulleys the band P, whereby the revolution of the drum J, when connected by its clutch with the pulley, gives movement to the band. Projecting inward from the lower end of the slide E is the wire arm Q, which is bent double, as represented in the drawings, to form the parallel slot n, for the movement toward and from the slide of the lower end of the link S, the upper end of which is made fast to the band P. The lower end of the link has a head, o, beneath the slot n, to prevent it rising out of said slot during the movements of the band. The lower cheeks on the peripheries of the pulleys O and O' have beveled teeth p, which connect with the link S as it comes in contact with either pulley; and as the lower end of the link has a free movement in the slot n of the arm Q of the slide E, when the upper end of the link connects with the teeth of the pulley, it is carried by means of its con-

nection with the band to the opposite side of the same, and thence to the pulley at the opposite end of the mule, where a similar reverse movement takes place, and thus a reciprocal movement of the slide E is kept up from end to end of the mule for clearing the roller-beam, &c.

Connected with the upper side of the pulley O' is the circular brush U, which has tufts of bristles e', that project downward, so as to sweep the fly from the band P, which would otherwise collect upon it so as to retard its movements.

I claim as my invention—

1. The combination, with the roller-beam and its specified attachments, of the reciprocating slide E, provided with the brush-block h, said block having tufts of bristles e e e, and an offset at the upper end of said slide, to clear the steel roller-stands on the upper side of the roller-beam as the slide passes in front of the same in clearing the beam, substantially as set forth.

2. The longitudinal wire i, having elbows i' i', in combination with the reciprocating slide E, strip g, and blanket-apron F, substantially in the manner and for the purpose set forth.

3. The revolving brush U, in combination with the band P, the brush being driven by means of the pulleys O' O and band P, or other equivalent mechanism, substantially as set forth.

4. The combination of the cord m, having a weight, N, with the back-shaft D, drum J, supporting-pulley L, and driving-pulley O, substantially as and for the purpose set forth.

SEVERIN MOCK.

Witnesses:

J. H. ANDERS,
EUGEN MOCK.