

G. F. CARD.
Cartridge-Loading Device.

No. 209,956.

Patented Nov. 19, 1878.

Fig. 1.

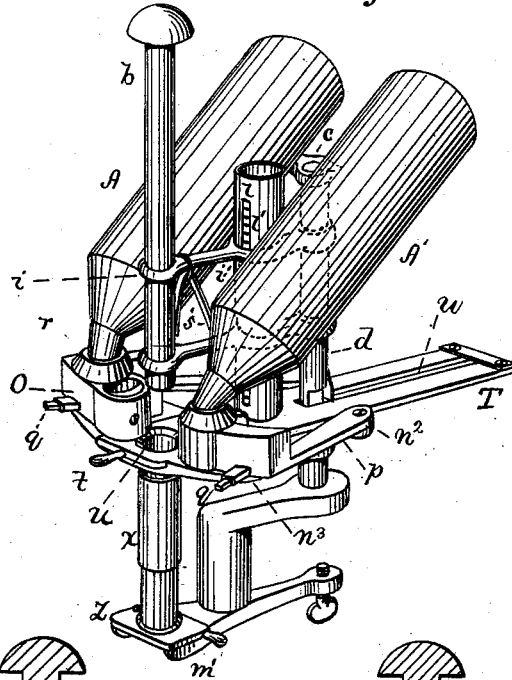

Fig. 2.

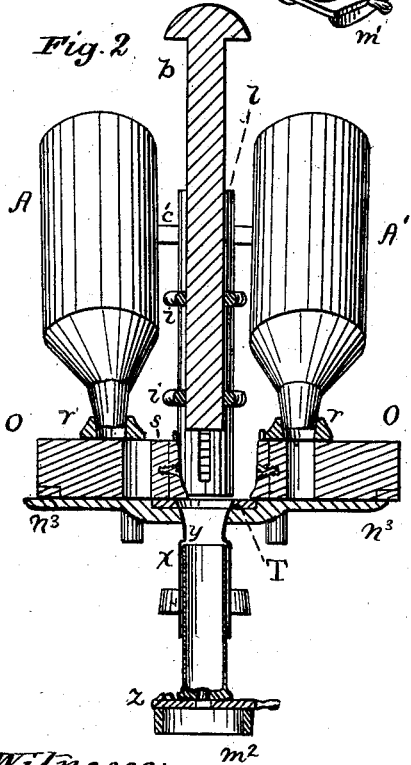
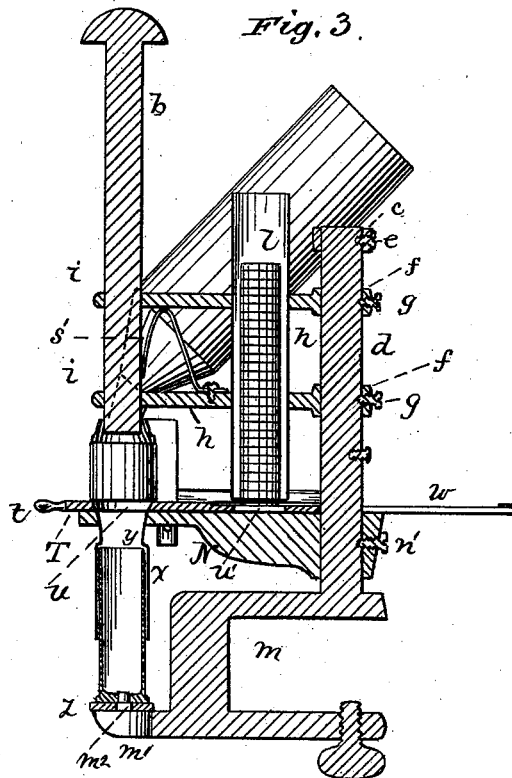

Fig. 3.



Witnesses:

E. E. Masson

E. W. Barney

Inventor:

George F. Card
by Chas. H. Page
his Attorney.

UNITED STATES PATENT OFFICE.

GEORGE F. CARD, OF GUTHRIE, ILLINOIS, ASSIGNOR OF ONE-HALF HIS
RIGHT TO THOMAS F. CORRY, OF COVINGTON, KENTUCKY.

IMPROVEMENT IN CARTRIDGE-LOADING DEVICES.

Specification forming part of Letters Patent No. **209,956**, dated November 19, 1878; application filed
April 9, 1878.

To all whom it may concern:

Be it known that I, GEORGE F. CARD, of the village of Guthrie, in the county of Ford and State of Illinois, have invented certain new and useful Improvements in Machines for Loading Cartridges Used in Sporting-Guns; and I do hereby declare that the following is a full, clear, and exact description of the invention, which will enable others skilled in the art to which it appertains to make and use the same, reference being had to the accompanying drawings, and to letters of reference marked thereon, which form a part of this specification.

My invention relates to certain improvements in the construction of that class of machines for loading cartridges for sporting-guns in which the charger is adapted to slide from under a hopper to and over the shell, whereby a charge is conveyed from the hopper to the shell of the cartridge and then dropped into the same.

In the drawings, Figure 1 is a perspective view of a machine for loading cartridges, and embodying my improvements. Fig. 2 is a vertical section taken through the chargers and tube surrounding a cartridge-shell. Fig. 3 is a vertical central section of the machine, taken on a plane between the two hoppers or reservoirs for powder and shot.

A represents a hopper for holding powder, and A' a similar hopper for containing shot. These hoppers are inclined toward the rear portion of the machine, as shown in Fig. 1, so as to admit of the rammer *b* being readily grasped and operated by a person loading the cartridge. The two hoppers are secured to and supported by the arms *c'* of a collar, *c*, which is adjustably secured upon a standard, *d*, by means of a set-screw, *e*. Upon standard *d* are also mounted two adjustable collars, *f*, which are secured in position thereon by the set-screws *g*. The two collars *f* have each an arm, *h*, which projects forward and at right angles to the arms which support the hoppers. The arms *h* have rings or collars *i*, two of which constitute guides and supports for the rammer *b*, and the remaining two supports for a slotted cylinder, *l*, for containing the wads to be used in loading the cartridges.

The standard *d* is formed in one piece with or secured to a clamp-frame, *m*, which is provided with a clamping-screw, for securing the machine in convenient position upon the edge of a table.

N is a bed-piece, which is adjustably secured upon standard *d* by a set-screw, *n'*, and which may be made of either wood or metal. This bed-piece is formed with two side extensions at the rear for the pivots of the charger-block arms, with two side extensions at the front for the charger-blocks to move upon, and with a central grooved way, running its entire length, for a slide which carries forward the wads from the wad-cylinder, as will be hereinafter more fully set forth.

o o represent the two chargers, which consist of segmental-shaped blocks, enlarged at one end and having an opening formed through said enlargements. One block thus formed is adapted to convey a charge of powder and the other a charge of shot to the cartridge-shell. These blocks have arms *P*, which are pivoted to the extensions *n''* at the rear of the bed-piece, and are also provided with handles *q*, for a ready manipulation of the same. As shown more clearly in Fig. 1, each block has, in addition to its enlarged recessed portion, a segmental-shaped part, with flat upper and lower surfaces. The under faces of the same slide smoothly upon the front extensions, *n'''*, of the bed-piece, which, if the bed-piece be made of wood, should have a thin plate of metal secured thereon. The smooth upper faces of the blocks pass along the under side of the cut-offs *r r*, each one of which is secured in position under the smaller end of a funnel-shaped portion of the hoppers. These cut-offs consist of blocks or pieces, with openings through the same, and a flaring base, so that a smooth and extended under surface may be brought in contact with each of the blocks, and are mounted in the bed-piece by suitable blocks or rods. Within each charger is a block, *s*, secured by a screw and adapted for removal, so that blocks of various sizes may be inserted, and the size of the charge thereby varied.

T represents a flat side of wood or metal,

formed with a handle, *t*, and fitted to move backward or forward within a grooved way formed in the bed-piece N.

The grooved way for the slide is intermediate of the hoppers, and extends from front to rear of the bed-piece. The slide T is formed with two openings, *u* *u'*, and a slot, *w*, through which the standard *d* passes. The forward opening, *u*, comes directly over a corresponding opening formed in the bed-piece near its front when the said slide is pushed back to its farthest limit, which will be determined by the upright *d* coming in contact with one end of the slot *w*, and in this position the rear opening, *w*, in the slide will come directly under the cylinder *l*, which contains the wads. The thickness of the slide is just equal to the thickness of a wad, so that but one wad at a time will drop into the opening *w*. The grooved way in the bed-piece is also of such depth that the upper surface of the slide shall be flush with the surfaces of the bed upon which the charger-blocks slide. Within the forward opening in the bed-piece N, which is directly under rammer *b*, is screwed a tube, *x*, somewhat contracted at its upper end, so as to form a shoulder, *y*, therein, whereby when a cartridge-shell is inserted in the tube the same will be in line with the shoulder, and hence no obstructing edge presented to the rammer or wads.

z is a flat swinging seat for the cartridge, and is pivoted to an extension, *m*¹, of the clamping-frame, so that after a cartridge-shell has been inserted in the tube it may be brought in position under the same, thereby forming a firm support while the shell is being loaded.

In order to prevent any explosion of the cap while the loading is being effected, I form an opening, *m*², in the seat, and so locate the same that it will come directly under the cap.

The bed-piece N is made adjustable upon standard *d*, as before described, so that the same and tube *x* may be raised or lowered to suit cartridges of various lengths. To adjust the same, however, for cartridges of varying diameters, the tube *x* may be unscrewed and replaced by a tube corresponding in size to the cartridge.

The rammer *b*, which is guided by the rings *i* of the arms *h*, is maintained in an elevated position, when desired, by a bent spring, *s*, secured upon one of the arms *h*. When, however, the bed-piece is raised or lowered upon the standard, the arms *h* must also be similarly adjusted, so as to adapt the hoppers to such change of the bed-piece and chargers.

The operation is as follows: The swinging seat *z* is moved aside, the cartridge inserted in tube *x*, and the seat then brought back in position under the same, and with its opening

*m*² directly under the cap. The solid parts of the blocks O being now under their respective cut-offs *r* under the hoppers, one of the same is moved by means of its handle along the bed until the charger-tube in the block is brought under the cut-off and filled with powder. The block is then moved over the bed until the charger with the powder comes over the front opening in the slide, which should be over the tube *x*, so that the powder will be discharged into the shell. During this movement the solid surface of the block O comes directly under the cut-off, and hence the flow of powder through the same will be stopped. The charger is then moved away and the slide T drawn forward, bringing with it one wad in its rear opening, *w*, until the wad comes over the shell, into which it will drop. The slide may then be pushed back for another wad, to be used after a charge of shot has been carried into the shell by the other charger in the same way. After pushing back the slide, as above, the rammer may be depressed and the wad driven home upon the powder in the shell. By means of spring *s'*, the rammer, after such use, will be held in place within its guides in a position to clear it from the chargers. The other charger, for shot, is manipulated in the same way as in the case of the one for powder, and the rammer again brought into play.

The supply of wads can be readily seen through a slot, *v*, in the wad cylinder or reservoir *l*.

What I claim as my invention, and desire to secure by Letters Patent, is—

1. In a machine for loading cartridges, in combination with a standard supporting the adjustable bed-plate with its pivoted chargers, the two adjustable arms *h*, supporting the wad-cylinder *l* and guiding the rammer, and the two cylinders A A', for powder and shot, said cylinders being also adjustable upon the standard through the medium of a cross-arm, all constructed and arranged substantially as herein shown and described, and for the purposes set forth.

2. In combination with the chargers, each composed of a pivoted arm, *p*, and a cut-off block, with an opening for the passage of the charge, the short tubes *r*, each formed with a flaring base and secured upon the bed-plate, and the adjustable hoppers, as herein shown and described, and for the purpose set forth.

In testimony that I claim the foregoing as my own I have affixed my signature in the presence of two witnesses.

GEORGE F. CARD.

Witnesses:

H. A. RANEY,
A. T. LEWIS.