

G. C. CLARKE.
Bale-Tie.

No. 209,958.

Patented Nov. 19, 1878.

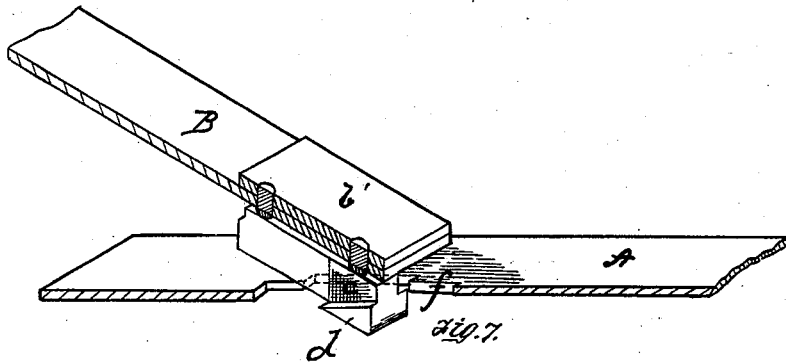
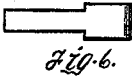
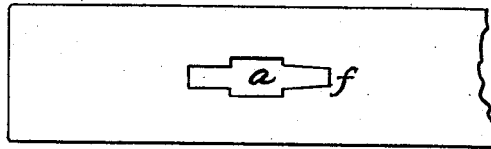
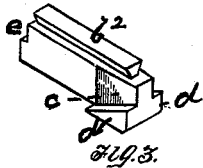
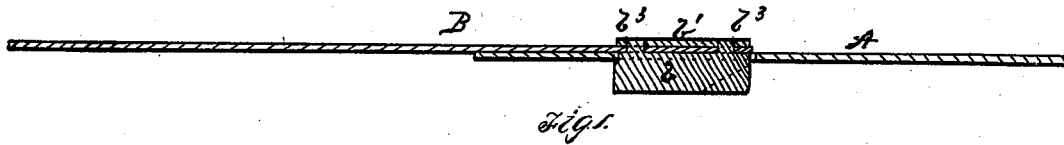

Witnesses.

John H. Smith
R. H. Whittlesey

Inventor.

George C. Clarke
by Bakewell & Kerr
Attys

UNITED STATES PATENT OFFICE.

GEORGE C. CLARKE, OF CLEVELAND, OHIO.

IMPROVEMENT IN BALE-TIES.

Specification forming part of Letters Patent No. **209,958**, dated November 19, 1878; application filed August 14, 1878.

To all whom it may concern:

Be it known that I, GEORGE C. CLARKE, of Cleveland, in the county of Cuyahoga, and State of Ohio, have invented a new and useful Improvement in Bale-Ties; and I do hereby declare the following to be a full, clear, and exact description thereof, reference being had to the accompanying drawing, forming part of this specification, in which—

Figure 1 is a sectional view of a bale-tie embodying my invention. Fig. 2 is a view of the slotted end of the band. Fig. 3 is a perspective view of the cleat detached. Fig. 4 is a top, and Fig. 5 an end, and Fig. 6 a bottom view of the cleat detached from the band. Fig. 7 is a view illustrating the manner of inserting the cleat in the slot, partly in section to show a second method of attaching the cleat to the band.

Like letters refer to like parts wherever they occur.

My invention relates to certain improvements in bale-ties, hereinafter described, and specifically pointed out in the claims.

I will now proceed to describe my invention, so that others skilled in the art to which it appertains may apply the same.

In the drawing, A and B represent the ends of a bale-tie, one provided with a rectangular cleat and the other slotted to receive the cleat. *b* indicates the rectangular cleat, somewhat less in length than the slot which it is to enter. Said cleat is preferably tapered at its forward end, as at *e*, in order that the band may not be unnecessarily weakened by the size of slot required, and is provided with flanges or lugs *d*, which project laterally, so as to take under the band, and are, by preference, inclined or wedge-shaped, as shown, so as to permit the cleat to enter the slot readily, and at the same time preserve the contact of the band-surfaces and prevent the disengagement of the parts.

The heel of cleat *b* may be notched, as at *e*, to engage with the edge of the slot, and thus aid the inclined flanges in preserving the contact of the band ends. This cleat will preferably be made of malleable iron, and can be secured to the band end B (which is usually

reinforced by a washer or otherwise, as at *b*¹) by either an oblong rivet, *b*², or by a series of round or square rivets, *b*³, as preferred.

The end A of the band is provided with a series of slots, which are widest at the center, as shown at *a*, to permit the passage of shoulders or flanges *d*, and taper at the forward ends, as at *f*, to cause the band to engage with the flanges, said slots being somewhat longer than the cleats *b* used therewith.

In securing the band, the cleat end thereof is held at such an angle (Fig. 7) as will permit the wedge-shaped flanges to enter one of the slots at the widest part, *a*. The cleat end of the band is then brought down against the slotted end, which carries the flanges *d* forward, forcing the wedge end of the cleat into the narrowed portion *f* of the slot, so that the flanges *d* take well under the slotted end of the band. As the cleat rides forward the heel of the lug settles in the slot, and the notch *e* takes the edge of the slot, assisting the wedge-flanges to perfect the tie or lock.

The advantages of my invention are, first, great security, as the lock or tie cannot become unfastened until the cleat-band assumes the position shown in Fig. 7, which position it cannot assume accidentally; secondly, the readiness with which the tie can be loosened by prying up the cleat end of the band; thirdly, the strength obtained by the manner of shaping the cleat and slot; finally, the simplicity and reduced cost of manufacture.

Having thus described my invention, what I claim, and desire to secure by Letters Patent, is—

1. The rectangular cleat, slightly less in length than the slot with which it is to engage, and having side flanges at its forward portion, which flanges are non-registering, or incapable of registering with the slot when the cleat is wholly within the slot, substantially as and for the purpose specified.

2. A bale-tie cleat having a rectangular body wedge-shaped at its forward end, and having the wedge-shaped flanges on the two sides of the wedge end of the cleat, substantially as and for the purpose specified.

3. A rectangular cleat for bale-ties, said

cleat provided with longitudinally wedge-shaped flanges at or near one extremity and a notched heel at the opposite extremity, substantially as and for the purpose specified.

4. A bale-tie provided with a rectangular cleat, tapered and flanged at its forward end, and a slot of sufficient width at or near its middle to admit the flanges of the cleat, and tapered from its widest part to increase the

underlapping of the flanges without weakening the band, substantially as specified.

In testimony whereof I, the said GEORGE C. CLARKE, have hereunto set my hand.

GEORGE C. CLARKE.

Witnesses:

JNO. C. WEBB,

WILLIAM E. CLARKE.