

F. BROTHERHOOD.  
Rice Pounding and Hulling Mill.  
No. 210,002. Patented Nov. 19, 1878.

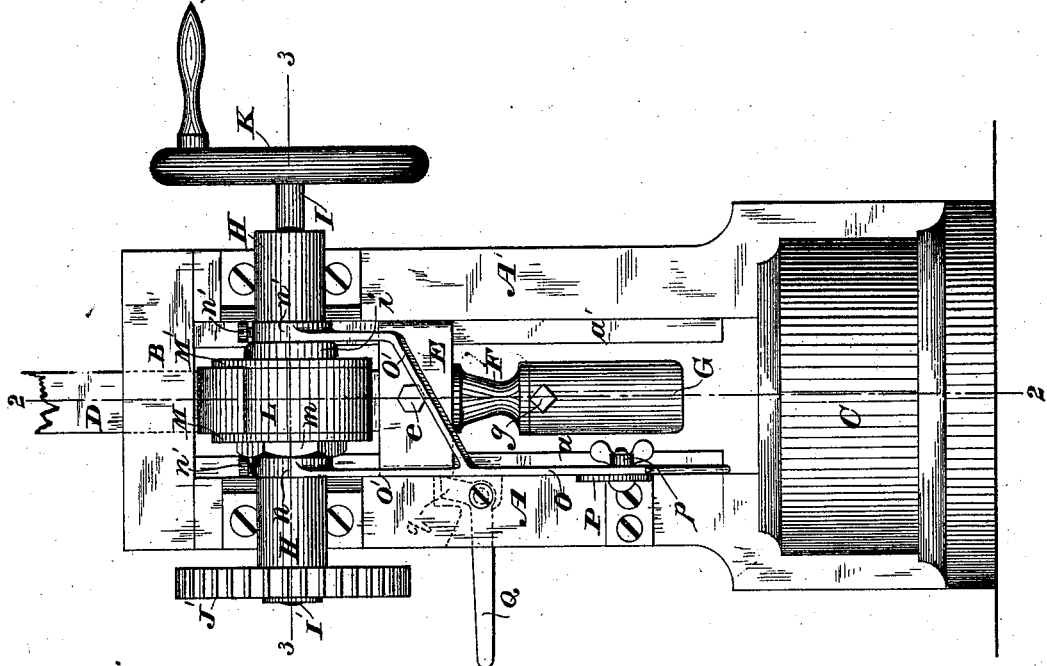

Fig 1.

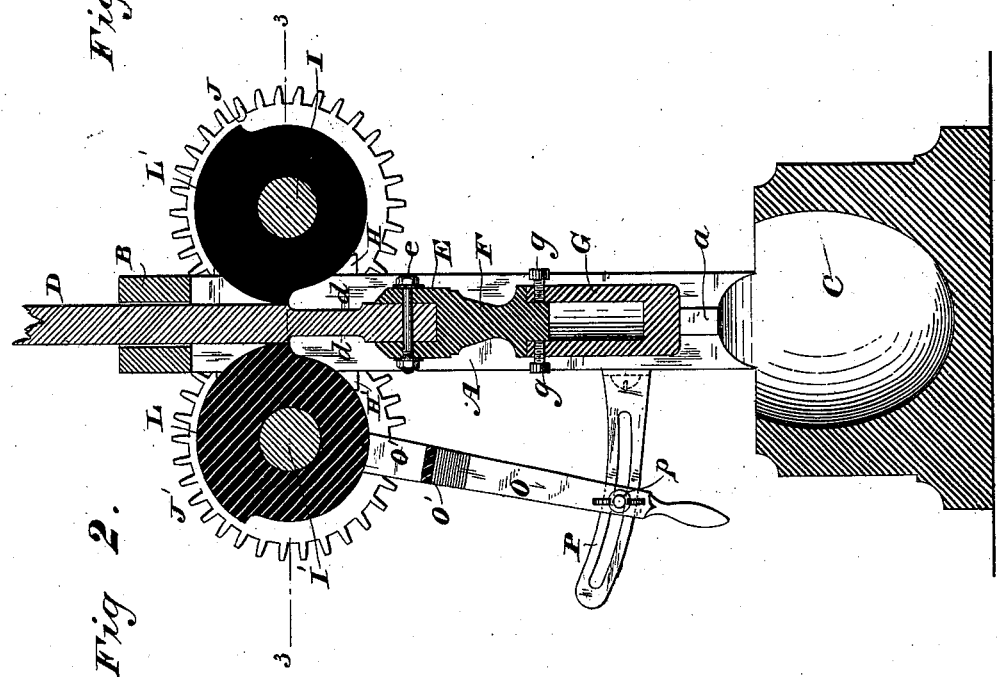

Fig 2.

WITNESSES

*Wm A Skinkle  
Ed Davidson.*

INVENTOR

*Fred Brotherhood.*

By his Attorneys

*Baldwin, Hopkins & Lytton.*

F. BROTHERHOOD,  
 Rice Pounding and Hulling Mill.  
 No. 210,002. Patented Nov. 19, 1878.

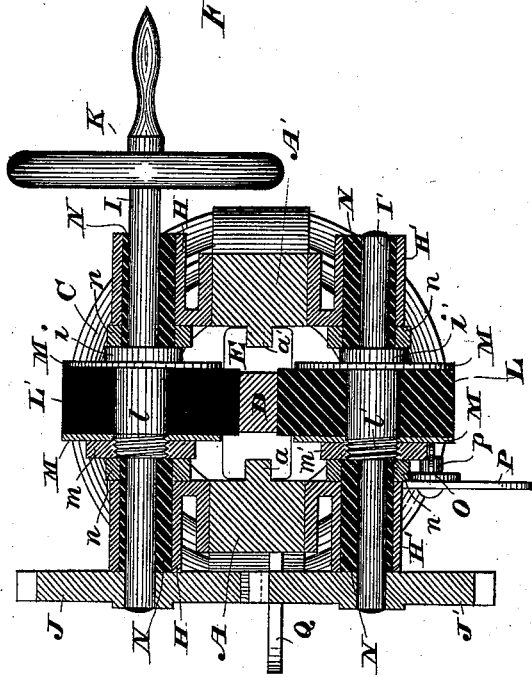

Fig. 3.

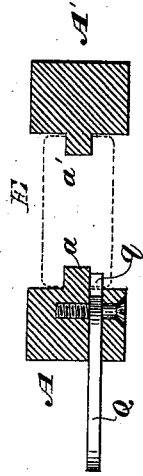
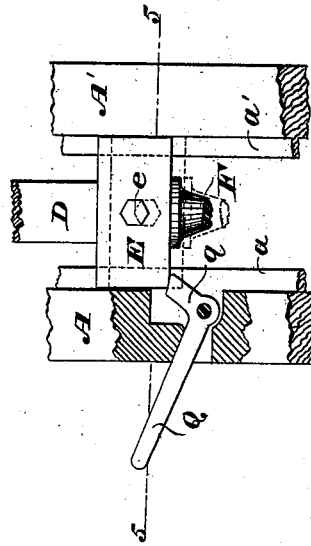

Fig. 5.

Fig. 4.



WITNESSES

*Wm a Shinkle*  
*E. Davidson.*

INVENTORS

*Fred Brotherhood,*  
 By his Attorneys  
*Galdwin, Hopkins & Peyton.*

F. BROTHERHOOD.  
Rice Pounding and Hulling Mill.  
No. 210,002. Patented Nov. 19, 1878.

Fig 6.

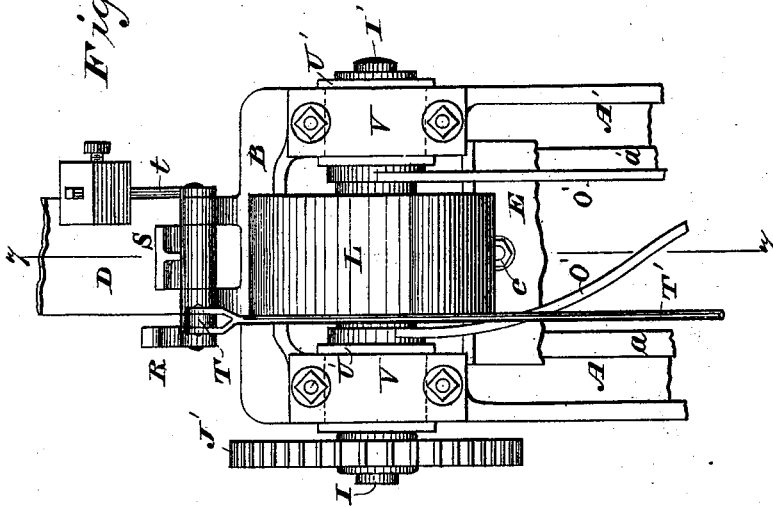
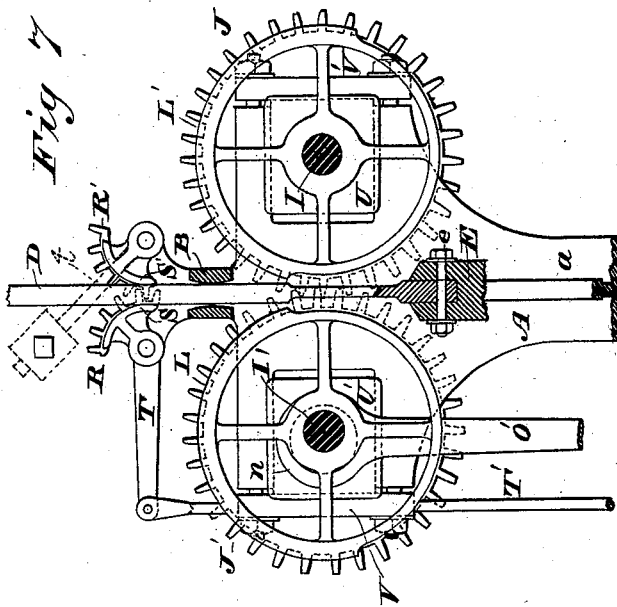

Fig 7.



WITNESSES

*Wm A Skittle*  
*Ed Davidson.*

INVENTOR

*Fred Brotherhood.*

By his Attorneys

*Baldwin, Hopkins & Peyton.*

# UNITED STATES PATENT OFFICE.

FRED BROTHERHOOD, OF CHARLESTON, SOUTH CAROLINA.

## IMPROVEMENT IN RICE POUNDING AND HULLING MILLS.

Specification forming part of Letters Patent No. **210,002**, dated November 19, 1878; application filed September 18, 1878.

*To all whom it may concern:*

Be it known that I, FRED BROTHERHOOD, of the city of Charleston, in the State of South Carolina, have invented certain new and useful Improvements in Rice Pounding or Cleaning Mills, of which the following is a specification:

My invention relates to improvements in mills for cleaning or pounding rice of the class having rapidly-operating pestles, automatically lifted and released, so as to descend or fall by gravity into the rice to be cleaned in the mortars.

My objects are to provide a light, cheap, simple, compact, and durable mill, and one which shall require but a small amount of power to work it, and which may quickly be thrown into or out of operation.

My improvements consist of a novel organization of devices and in certain combinations of parts, hereinafter first fully described, and then specifically designated by the claim.

In the accompanying drawings, Figure 1 is a front elevation of the mill, showing my improvements in the form which I deem preferable; Fig. 2, a vertical section on the line 2 2 of Fig. 1; Fig. 3, a horizontal section of the lines 3 3 of Figs. 1 and 2. Fig. 4 is a view in detail, with a portion of one of the uprights broken away, showing the lifting-board or pestle-carrying rod as elevated and secured in such position as not to be operated upon by the lifting devices; Fig. 5, a section on the line 5 5 of Fig. 4. Fig. 6 is a front elevation of the upper part of the mill, showing a modification of the way of holding up the lifting-board; and Fig. 7, a section through the frame and other parts of the modified mill on the line 7 7 of Fig. 6.

The supporting-frame, composed either of wood or metal, the latter material being preferable, consists of two stout posts or uprights, A A', connected at top by a cross-piece, B, and joined together at their lower ends by a mortar, C, if it is made of metal, or by any suitable base-plate, or by a direct attachment to the floor. If a wooden mortar is employed, as I prefer, it may be suitably secured between the frame-uprights in such a manner as to be readily removable, so that it may be replaced by another, if necessary.

A guide-slot is provided in the top of the frame or cross-piece, B, through which the reciprocated rod or pestle-lifting board D plays up and down as it alternately ascends when acted upon by the elevating devices, and descends when released by them.

A cross-head, E, is secured to the lower end of the lifting-board D, and is guided by vertical ribs or inwardly-projecting rail-like flanges *a a'* of the uprights A A'.

A metallic pestle-connecting piece or boot, F, formed with or secured to the cross-head, serves to attach a pestle, G, to the cross-head of the lifting-board. This boot, at its upper end, is firmly fitted to the lifting-board, being secured thereto with the cross-head by the bolt *e* and its nut, or by set-screws. The bolt passes through the cross-head and boot and the lifting-board, and may readily be removed to separate the parts. At the lower end the boot is fitted to the pestle and secured by set-screws *g g*. In this way one boot may be substituted for another, or the pestle changed, and the distance between the cross-head and the lower end of the pestle be increased or diminished to suit the work to be done, and to properly adjust the pestle to operate upon the rice in the mortar. Heavy or light boots and cross-heads may be used, according to the character of the work to be performed. Sometimes it is desirable to strike heavy blows, and at other times lighter ones, according to the condition of the grain. The heavier the boot is made the greater will be the force of the blows, obviously. The boot may consist of an intermediate piece, separable from both the cross-head and pestle, and thus admit of changing the boot without removing the cross-head.

Suitable shaft-housings or journal-bearings H H H' H' for a driving-shaft, I, and driven shaft I' are secured by screws or otherwise to the front and back of the supporting-frame, near the tops of its uprights A A'. A spur-gear, J, on one end of the driving-shaft, meshes with and drives a corresponding gear-wheel, J', fast on the driven shaft, as the shaft I is revolved by the application of power in any suitable way.

A driving-wheel and its hand-crank K are shown by the drawings as the means employed for operating the mill; but in practice I em-

ploy a band-wheel, and drive it by a steam-engine or other motive power. Cams or eccentric-rolls  $L L'$ , one on the driving-shaft and the other on the driven shaft, revolve with the respective shafts, and act upon the lifting-board  $D$  on opposite sides throughout a portion of each revolution of the shafts.

The cam-surfaces of the rolls may be of any length desired, so long as they extend for less than half—say two-fifths—the circumference of the rolls, the length of the cams depending upon the lift or length of the stroke which it is desired to give the pestle. The cams may be of metal, wood, rubber, &c.; but I prefer to employ rubber, and to make the cam-rolls separate from their respective shafts, and to secure them in position in such way as to be readily detachable. In this instance, one roll,  $L$ , is shown as composed of wood, and the other,  $L'$ , of rubber, and each shaft is formed with an annular shoulder,  $i$  or  $i'$ , near one of its bearings, and is made large at and near its middle portion, and this enlargement terminates in a screw-thread,  $l$  or  $l'$ . Clamping-disks or loosely-fitted annular collars  $M M'$  on the shafts  $I$  and  $I'$  serve, in connection with the screw-threads  $l l'$ , shoulders  $i i'$ , and nuts  $m m'$ , to clasp the cam-faced rolls firmly upon the shafts. The inner faces of the collars, or of one of the collars for each shaft, are roughened or serrated, so as to prevent slip of the rolls on their shafts independently of the collars.

By increasing the pressure upon the rubber cam-rolls from time to time, as occasion may require, the rolls may be compressed in the direction of the length of the shafts and slightly spread or caused to project outward from the shafts, and thus give increased prominence to the cam-surfaces to compensate wear either of the cams or the lifting-board, as well as to enable these parts properly to be adjusted relatively to each other in setting up or starting the mill.

Either the driving-shaft or the driven shaft, or, as shown by the drawings, both these shafts, may be rendered adjustable in their bearings, so as to compensate wear of the cams and the lifting-board; and when both shafts are so mounted in their bearings as to be adjustable, fixedly attached cam-rolls, or those having no adjustment independently of the shafts  $I$  and  $I'$ , may be employed, if desired, and be made of metal, wood, or other durable and non-compressible slightly-yielding material.

To provide for the adjustment of the shafts so as to cause the cams  $L L'$  to approach or recede from each other, and to enable an attendant to make the requisite adjustment while the mill is working, I mount the shaft ends in adjustable bushings or boxes, and connect a lever to them, the handle of which extends down a suitable distance to bring it within convenient reach of the attendant, and is adapted to be held in any position desired.

As shown by Figs. 1, 2, and 3, I attain the objects sought by the following construction

and adaptation of parts: Boxes or bushings  $N$ , having the shafts  $I I'$  mounted eccentrically therein, are adapted to the bearings or housings  $H H'$ . Adjustable collars  $n n$  upon the inwardly-projecting ends of the eccentric bushings are fixed in the desired position by set-screws  $n' n'$ . A bifurcated lever,  $O$ , formed with or secured at the ends of its forks  $O' O'$  to the collars, is provided with a handle at its lower end, and may be held in any desired position, to lock the bushings when adjusted, by a curved segmentally-slotted securing or detent arm,  $P$ , and a clamping thumb-screw or pinch-nut,  $p$ , as is well understood. The securing-arm is attached to the upright  $A$  of the supporting-frame. The adjusting-lever is shown as provided for but one set of bushings, those of the driven shaft  $I'$ ; but a similar lever and holding devices may be used in connection with the driving-shaft bushings.

As shown by the drawings, however, the driving-shaft may be adjusted by means of a wrench fitting upon the collars  $n n$ , polygonally formed for this purpose. When adjusted the bushings may be secured by set-screws passing through the housing  $H' H'$ . The very slight adjustment which may be required while the mill is at work may be accomplished by the single lever. At no time will any considerable adjustment be required. By manipulating the lever  $O$ , the cam  $L$  may be caused to revolve free of the lifting-board, and thus throw the mill out of operation.

To hold the pestle in an elevated position, and to enable an attendant to stop the up-and-down movement of the lifting-board at any time desired without stopping the revolution of the cams  $L L'$ , so that the mortar may be emptied or filled, the condition of the rice inspected, &c., I provide a holding-up lever or rocking catch,  $Q$ , pivoted in a slot in the frame upright  $A$ . The short arm or toe  $q$  of this lever may be caused to pass beneath the cross-head  $E$  and stop its descent, while holding the lifting-board in the proper position to cause the cams to work opposite to the cut-away or recessed parts  $d d$  of the lifting-board, and thus move free of the board as they rotate.

In Figs. 1 and 2, and in dotted lines in Fig. 4, the cross-head is shown as at the highest point to which it is positively lifted by the cams—that is to say, were the cams worked very slowly they would cease to move the lifting-board upward at the time they finished acting upon the thick or regular part of the lifting-board.

The toe  $q$  of the lifting-board holding-catch is slightly higher than the point at which the positive elevation of the lifting-board by the cams ceases, so that when the catch is caused to engage the cross-head by rocking the lever the lifting-board is held in proper position to have the thin or cut-away part  $d d$  between the cams, so that they will not move in contact with the board.

When at work the pestle is operated rapid-

ly, and the inertia or momentum of the lifting-board carries the cross-head somewhat above the point at which it is represented in Figs. 1 and 2 and by dotted lines in Fig. 4, as well as above the end of the catch or toe *q* of the lever *Q*. By watching the movements of the lifting-board the attendant may cause the catch to engage the cross-head just as it commences to descend after being carried upward by the impetus imparted to the lifting-board beyond the point at which the cam-rolls act upon the lifting-board. It is only necessary to press slightly upward upon the outer end of the lever *Q* when the pestle is ascending to cause the catch to act. As the cross-head passes the catch on the upward movement of the board the catch yields; but because of the pressure upward on the lever the catch immediately swings inward across the path of the cross-head, and prevents its descent. Normally the lever occupies the position in which it is shown in Fig. 1, so as not to interfere with the movements of the lifting-board.

In Figs 6 and 7 slight modifications are represented. The changes made are as follows: Instead of the lever *Q* acting on the cross-head to hold up the lifting-board, I employ two sector-racks, *R R'*, at the top of the frame to actuate two rocking-clamps, *S S'*, carried by their shafts. These shafts are mounted in suitable bearings in brackets or uprights on the top of the frame. A lever, *T*, attached to one (*R*) of the racks, serves as a means to rock it and the corresponding rack, and cause the clamps to press upon opposite sides of the lifting-board, as will readily be understood from the drawings.

A link, *T'*, secured to the outer end of the rack-lever, enables the attendant to operate the clamps at the proper moment when the lifting-board is thrown up to engage and hold the board. The link may be secured at its lower end to a hook on the supporting frame or mortar, so as to keep the board elevated, when desired.

To throw the clamps out of operation by rocking them, a weighted lever, *t*, is connected with the shaft of the rack *R'*, as shown, and rocks it and the rack *R* in the direction opposite to that in which they are rocked by the lever. This weighted lever acts as soon as the lever *T* is released, and moves the clamps and holds them out of contact with the lifting-board.

Instead of eccentric bushings, as before described, sliding boxes *U U'* are shown in the modification, so that the cams may be adjusted by sliding the boxes in their ways or housings.

Securing plates or covers *V V'* and set-screws hold the boxes in proper position to keep the cams up to their work when adjusted.

In addition to the sliding box *U*, the eccentric bushing and lever *O*, before described, are employed.

With the above-described exceptions, and the further exception that instead of detachable cams and devices for securing them in

place the cams are formed upon the peripheries of the wheels, the parts are the same as already fully described.

I am well aware that revolving cams or eccentric-rolls and lifting rods or boards have heretofore been used in various kinds of machinery—such, for instance, as stamp-mills or ore-crushers, drop-hammers, and fulling-mills; and I do not therefore claim the combination, broadly considered or in every organization of mechanism, of such rolls and lifting-boards; nor do I broadly claim means for adjusting cams or cam-shafts relatively to lifting-boards.

I am not aware, however, of any organization of mechanism essentially similar to that hereinbefore described, whereby the cam-operated lifting-board is adapted to actuate the pestle of a rice-pounding mill, and the mechanism combined and arranged for operation in the manner explained and shown.

By my peculiar organization and adaptation of devices I provide a light-running, portable, efficient mill for cleaning rice, which, both as regards the general features of construction and mode of operation, and various minor parts or details, is unlike any rice-cleaning mill heretofore known, of which I have knowledge.

I claim as of my own invention—

1. The combination, substantially as hereinbefore set forth, of the supporting-frame, the mortar, the lifting-board, cut away or recessed as at *d*, the pestle carried by the lifting-board, and the cams acting on the lifting-board above its cut-away portion only, whereby, when the board is thrown up by the impetus imparted to it by the cams above the point to which it is positively raised by the cams, it may be secured in an elevated position, free from the cams, by means substantially such as described, to throw the pestle out of operation without stopping the revolution of the cams.

2. The combination, substantially as hereinbefore set forth, of the supporting-frame, the mortar, the lifting-board actuating the pestle, and recessed or cut away, the cross-head at the lower end of the lifting-board below its cut-away portion, the cams, and the lever-catch to engage the cross head and throw the pestle out of operation, as described.

3. The combination, substantially as hereinbefore set forth, of the supporting-frame, the adjustable driving-shaft, the adjustable driven shaft, the cams on said shafts, the lifting-board carrying the pestle, the adjusting lever or levers, and connections between the lever or levers, and one or both of the cam-bearings, whereby the cam or cams may be adjusted toward or from the lifting-board and secured while the mill is working, for the purpose described.

4. The combination of the shaft *I'*, the cam thereon, the lifting-board acted on by the cam, the eccentric-bushings in which the shaft revolves, the collars on said bushings, the forked

lever, and the securing devices, these members being constructed and operating substantially as hereinbefore set forth.

5. The combination, substantially as hereinbefore set forth, of the cam-operated lifting-board, the pestle, and the removable boot, detachably connected both with the lifting-board and pestle, for the purposes specified.

6. The combination of the cam, the shaft on which it is mounted, having the enlarged middle portion and the screw-thread, the collars

on the shaft between which the cam is secured, and the clamping-nut, these members being constructed to operate in connection with the lifting-board, substantially as hereinbefore set forth.

In witness whereof I have hereunto subscribed my name.

FRED BROTHERHOOD.

Witnesses:

A. G. ROSE, Jr.,

ROLLO G. MURDOCH.