

J. A. HOUSE.
Sewing-Machine.

No. 210,036.

Patented Nov. 19, 1878.

Fig 1.

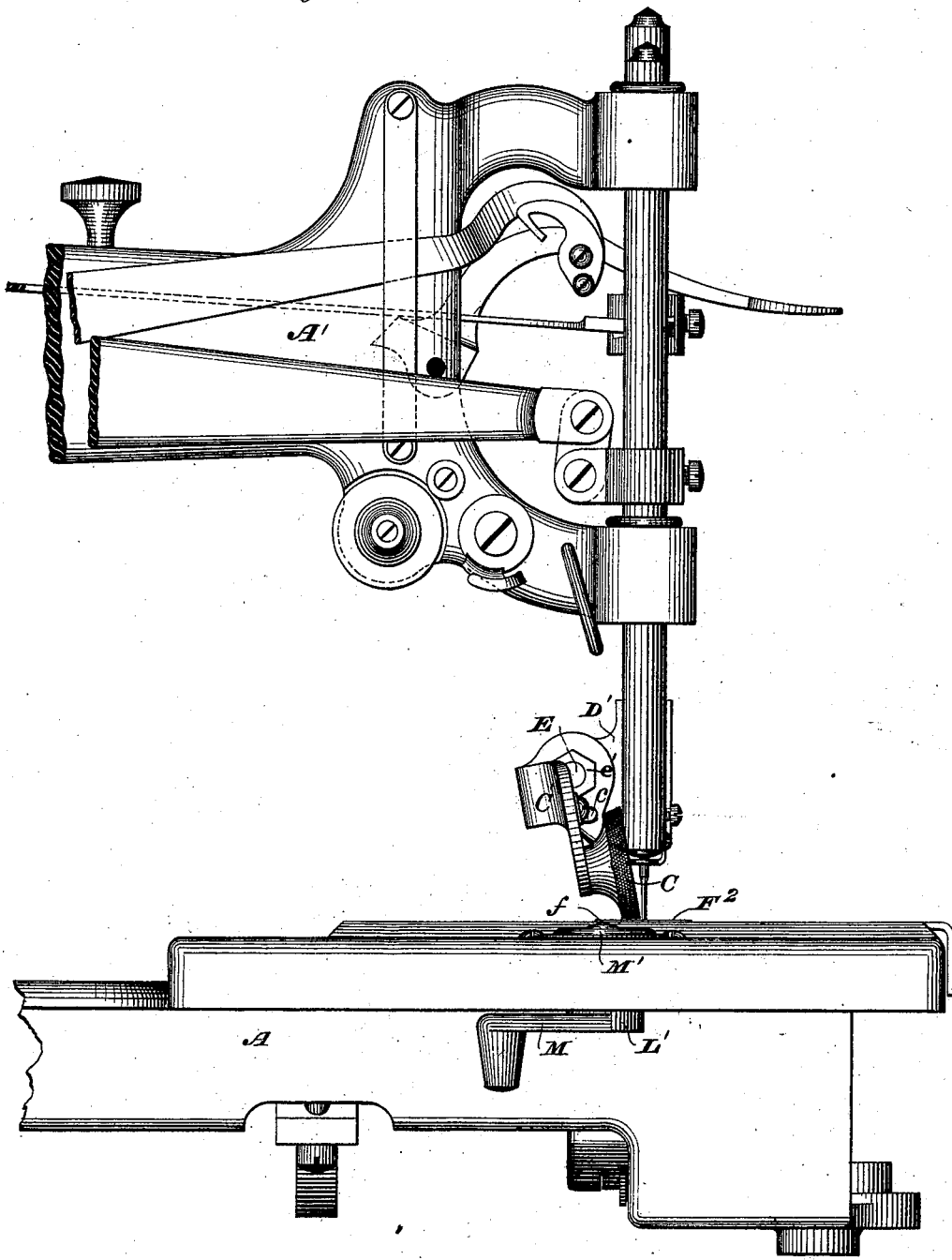

WITNESSES

Wm a Skinkle
Geo. W. Brock

INVENTOR

James A. House.

By his Attorneys

Baldwin, Hopkins & Taylor.

J. A. HOUSE.
Sewing-Machine.

No. 210,036.

Patented Nov. 19, 1878.

Fig 2.

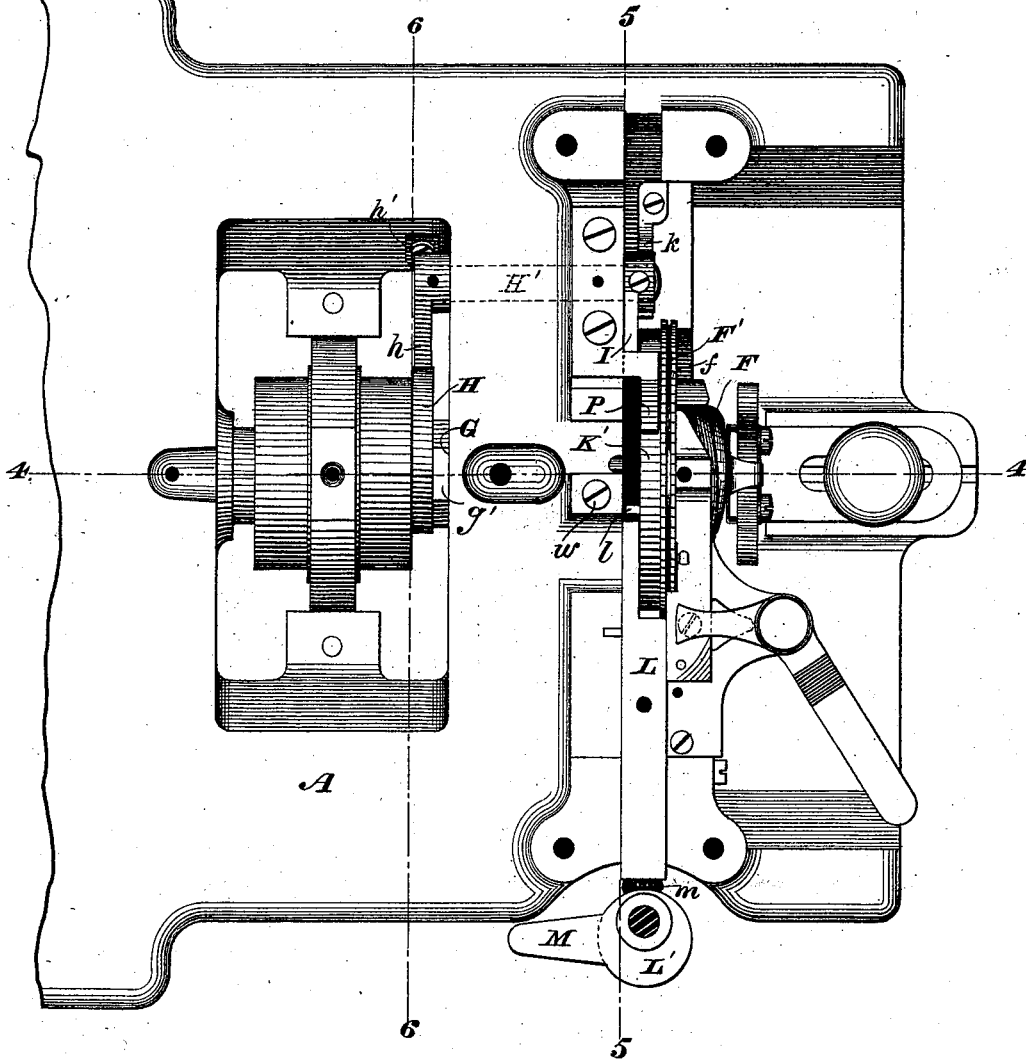

WITNESSES

Mrs A. Skinkle

Geo W. Buck

INVENTOR

James A House

By his Attorneys

Jaldwin, Hopkins & Lytton

J. A. HOUSE.
Sewing-Machine.

No. 210,036.

Patented Nov. 19, 1878.

Fig 7

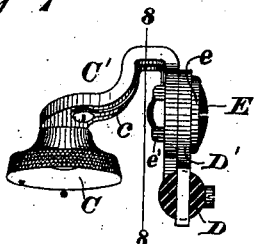

Fig 8.

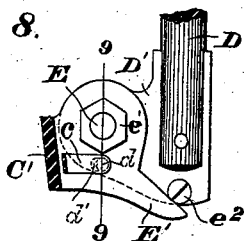

Fig 9.

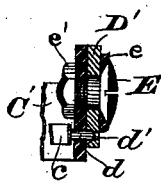
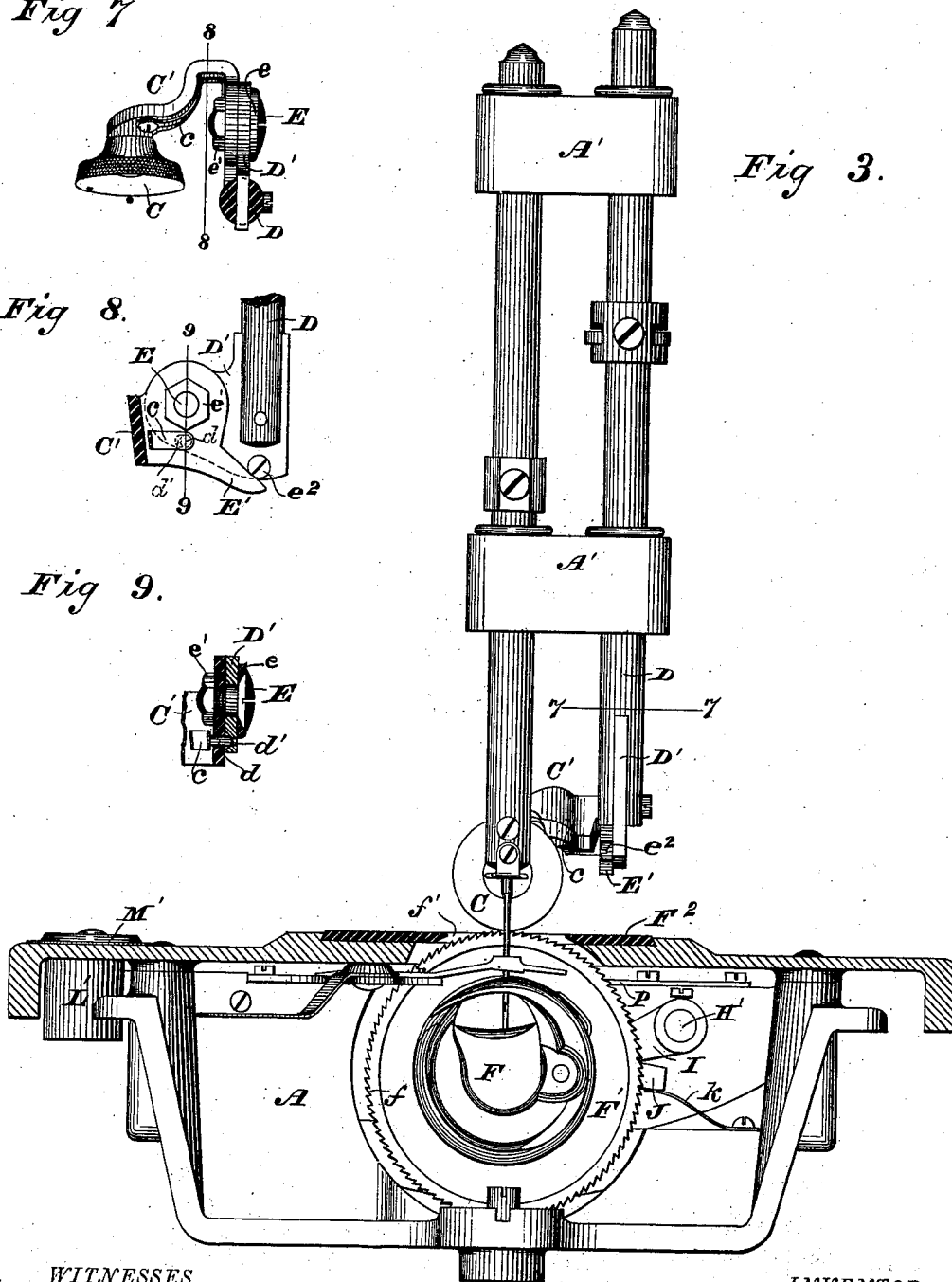

Fig 3.



WITNESSES

Mrs A. Skinkle
Geo. W. Brock

INVENTOR

James A. House.

By his Attorneys

Baldwin, Hopkins & Weston.

J. A. HOUSE.
Sewing-Machine.

No. 210,036.

Patented Nov. 19, 1878.

Fig 4.

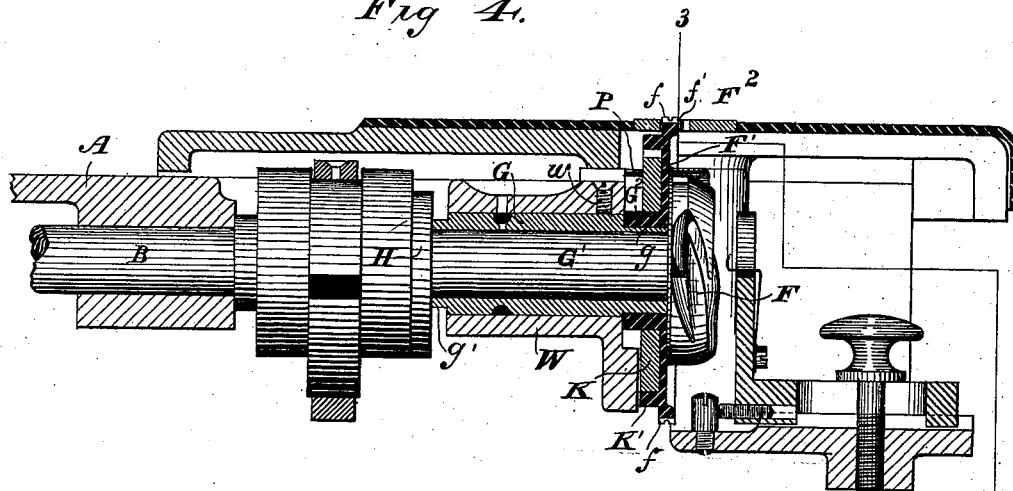

Fig 5.

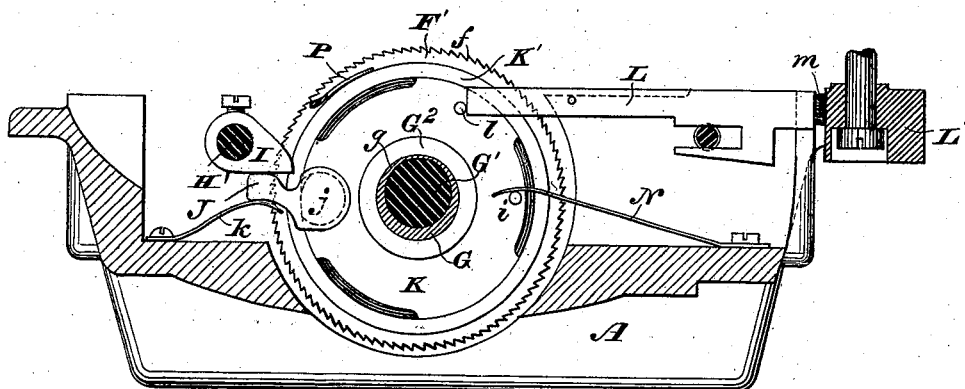
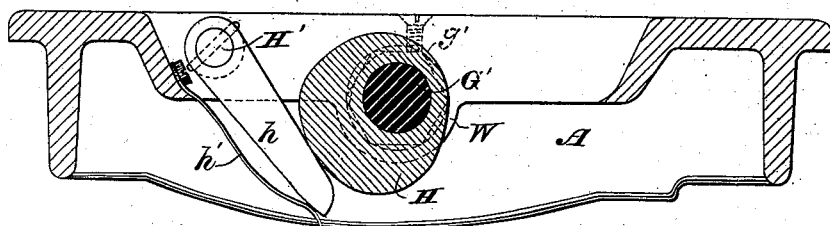

Fig 6.



WITNESSES

Mrs A Skinkle
Geo. W. Beck.

INVENTOR

James A House,

By his Attorneys

Dalwin, Hopkins & Taylor.

UNITED STATES PATENT OFFICE.

JAMES A. HOUSE, OF BRIDGEPORT, CONNECTICUT.

IMPROVEMENT IN SEWING-MACHINES.

Specification forming part of Letters Patent No. 210,036, dated November 19, 1878; application filed May 6, 1878.

To all whom it may concern:

Be it known that I, JAMES ALFORD HOUSE, of Bridgeport, in the county of Fairfield and State of Connecticut, have invented certain new and useful Improvements in Sewing-Machines, of which the following is a specification:

My invention relates, mainly, to improvements in devices for feeding the fabric, especially applicable to the well-known Wheeler & Wilson machine.

My improvements are, in this instance, shown as adapted to the Wheeler & Wilson No. 6 machine, which is generally similar to the sewing-machines illustrated and described in sundry Letters Patent of the United States heretofore granted me, especially the patent dated March 5, 1872, No. 124,360.

My object chiefly is to combine a wheel-feed with a rotary-hook sewing-machine, such as shown and described by said Patent No. 124,360; and my improvements consist in novel organizations of parts and in certain combinations of devices, hereinafter first fully described, and then specifically designated by the claims.

In the accompanying drawings, which show so much of a completely-organized sewing-machine as is necessary to illustrate the improvements herein claimed, Figure 1 is a side elevation; Fig. 2, a plan or top view, with the removable cloth-supporting plate or table detached, and the overhanging portion or bracket-arm of the frame, the needle-lever, &c., omitted; Fig. 3, a view, partly in front elevation and partly in transverse section on the line 3 3 of Fig. 4; Fig. 4, a longitudinal view, partly in vertical section on the line 4 4 of Fig. 2; Fig. 5, a transverse vertical section on the line 5 5 of Fig. 2; Fig. 6, a similar section on the line 6 6 of Fig. 2; Fig. 7, a transverse section through the presser arm or bar on the line 7 7 of Fig. 3, showing a plan view of the presser-foot; Fig. 8, a view, partly in elevation and partly in section on the line 8 8 of Fig. 7, showing the manner of attaching the presser-foot to its bar; Fig. 9, a section on the line 9 9 of Fig. 8.

The frame-bed A and bracket-arm or overhanging portion A' support the various moving parts of the machine, which are, unless it

is hereinafter otherwise stated, the same as or substantially similar to the improvements shown and described, or suggested as modifications, in my prior patents, particular reference being here made to the before-recited Patent No. 124,360. The driving-shaft B is provided with cams or known equivalents (not shown in the drawings) to operate the needle and take-up, as in said patent.

The presser-foot, to best suit it to the wheel-feed hereinafter to be described, instead of being such as heretofore employed by me, consists of a rotary disk or wheel, C, having a serrated periphery or roughened edge. The stud upon which this rotary presser-foot is mounted is secured to the outer end of an adjustable bent arm or bracket C', pivoted to a lug or plate, D', secured to the lower end of the presser arm or bar D. When swung down into its working position in well-known way, the presser-foot is locked in place by an end-wise-moving pin, d, working in a hole in the bracket C', and pressed by a spring, e, into a recess or opening, d', in the laterally projecting plate D' of the presser-bar. The force exerted by the spring upon the pin is sufficient to hold the presser-foot in proper position, while not so great as to prevent its being swung up by hand on its pivot, which is shown as formed by the adjustable screw E, provided with a washer, e, and nut e'. A heel-projection or stop-arm, E', on the bracket-frame abuts against a stop, e², on the presser-foot plate and limits the downward movement of the presser-foot, so that its swing-frame is stopped in proper position for the yielding locking-pin to engage its recess.

A rotary hook, F, such as fully described in my before-referred-to patent, is driven from the driving-shaft in the manner therein fully explained, so as to revolve with a differential velocity and seize and expand the loop of needle-thread.

To adapt a wheel-feed to this style of machine—that is, to combine such feed with a rotary hook—I employ a wheel, F¹, having a ratchet-toothed or serrated periphery, f, and mount this feed-wheel so that it projects slightly above the level of the cloth-supporting plate or table F² through a slot, f', therein beneath the presser-foot. This wheel is shown

by the drawings as formed with a flanged periphery, that the rotary hook may be adjusted close up to the face of the wheel, in proper position to engage the loop of needle-thread, and that the needle may play up and down close to the overhanging edge of the wheel. The wheel is also, in this instance, divided by an annular groove into two sets of ratchet-teeth. The revolving presser-foot is moved by the feed-wheel as it is intermittently turned or partially rotated about its axis, and a positive feed of the fabric between the presser-foot and wheel is insured. A sleeve-bearing or hollow stud, G, upon which the feed-wheel is mounted loosely, envelops the hook shank or shaft G¹, and is supported and held in its adjusted position by a set-screw, w, in a bearing, W, in the frame of the machine. This hollow stud is concentric with the hook-shank or rotary shaft G¹ throughout its bore or internal diameter. Upon its exterior, however, it is eccentric to said shaft G¹ at its outer end, g, where the hub G² of the feed-wheel rotates about it. At its opposite or inner end, g', it is made nut shape or polygonal, to admit of its being turned by a wrench, so as to oscillate the stud-shaft about the rotating shaft of the hook F, and thus adjust the feed-wheel up or down, so as to project more or less through the slot and above the table, to suit the work to be done.

Instead of the polygonal end of the stud, a downwardly-projecting crank might be used.

A partial rotation is imparted to the feed-wheel at regular intervals and when the needle is withdrawn from the fabric by suitable means, which, in this instance, consist, primarily, of a cam or eccentric collar, H, on the rotating hook shaft or shank, which cam operates upon a crank-arm or tappet, h, on the end of a rock-shaft, H', once for every revolution of the driving-shaft, to actuate the wheel by frictional clutch-connections. A spring, h', acts upon the tappet of the rock-shaft, so as to keep it up to the cam. The connections between the rock-shaft and feed-wheel, in this instance, consist of an adjustable toe or wiper, I, on the outer end of the shaft, or that end opposite the tappet h, which toe acts upon a griper, J, the inclined-faced lug or cam projection j of which (see dotted lines) is oscillated in a recess in a loose ring or disk, K, fitted upon the wheel-hub, and operating in a well-known way, so that as the griper-arm is struck by the toe or wiper it binds upon the inner surface of an annular ledge or flange, K', on the feed-wheel, and partially rotates it. A spring, k, throws up the griper after it is acted on by the wiper. A retrograde movement to the wheel is prevented by a spring, P, which bears with sufficient pressure upon the flange K' of the wheel to hold it by frictional contact against reverse movement. The griper is left in position to be again operated to partially rotate the wheel upon the next revolution of the shaft and cam.

To adjust the feed so as to vary the length of

the stitch, the disk K is provided with two pins, l, l', the former serving as a stop, against which a regulating-arm or endwise-moving bar, L, acts. This bar is operated by a cam, L', secured to a stud upon the under side of the cloth-supporting plate, and provided with a crank, M, and an indicator-plate, M', graduated, as usual, to show the adjustment of the feed-wheel. A spring-cushion or rubber block, m, is secured to the end of the bar, so as to prevent a too sudden shock in adjusting, and to hold the regulator-bar up to the pin l on the wheel, so as to be capable of slightly yielding. A spring, N, acts upon the pin l', with a tendency to rock the disk or ring K in a direction opposite to that in which the feed-wheel rotates. This tendency is checked as desired by the bar L.

From the above description it will be seen that the griper is always, after it is released from the toe or wiper of the rock-shaft, thrown upward the same distance by its spring k, and has at each stroke of the toe to describe a like portion of a revolution in its seat or recess in the ring before acting upon the feed-wheel.

It will also be apparent that the farther outward or away from the pin on the disk the regulator-bar is moved or allowed to move the greater will be the retrograde movement of the loose ring or disk, and the consequent upward movement of the griper by the action of the spring N. The higher the griper is moved, provided it is not adjusted so as to clear it from the rock-shaft toe as it revolves, the longer it will be operated upon by said toe and the greater will be the movement of the feed-wheel and the length of stitch.

It is deemed unnecessary to describe herein other details of the construction of the machine, as they form no part of the invention claimed; and it is not deemed essential that the peculiarities of construction and operation of the rotary hook be particularly described, as they are well known and have been fully set forth in my prior patents.

I have herein described only one way, and the best way now known to me, of carrying out my invention; but I do not confine myself to the details of construction, nor to the precise arrangements of parts specifically described and shown by the drawings, as other and equivalent ways—such, for instance, as would be suggested to a skilled mechanic by reading this specification and examining the accompanying drawings—of combining the peculiar rotary hook and a wheel-feed may be adopted.

The axis of revolution of the differentially-rotating hook is the same as that of the feed-wheel, or so nearly so as to be substantially the same, the only variation in the centers of rotation of the feed-wheel and hook being due to the slight eccentricity to the hook-shank of the bearing for the wheel upon the end of the stud enveloping the shank. The feed-wheel rotates vertically and in a plane parallel to

that of the hook, and acts upon the fabric through the slot in the work-supporting table, as will readily be understood.

By my invention, as shown in the drawings, it will be seen that the horizontal driven shaft or hook-shank in the line of the driving-shaft serves as a means of imparting the desired intermittent movement to the feed-wheel; that the wheel may readily be adjusted to suit variations in length of stitch and changes in the fabric; and that the operations of the needle, rotary hook, and feed-wheel are performed automatically. As the hook-shank has no endwise adjustment, and as there is no horizontal adjustment or movement endwise of the hook-shank of either the hook or wheel, they always rotate in parallel vertical planes at the proper distance apart, insuring uniform work, and preventing possibility of accidentally interrupting or impeding the operation of the needle working vertically between them.

I claim as of my own invention—

1. The combination, substantially as hereinbefore set forth, of the driving-shaft, the rotary hook-shaft, the rotary hook having a differential motion imparted to it, and the intermittently-operating feed-wheel revolving about the hook-shaft and actuated therefrom by connecting mechanism, substantially as described.

2. The combination, substantially as here-

inbefore set forth, of the frame of the machine, the rotary hook, its shank or shaft, the feed-wheel, and the hollow stud enveloping the hook-shank, and upon the eccentrically-formed portion of which the wheel is mounted so as to be capable of adjustment vertically.

3. The combination, substantially as hereinbefore set forth, of the driving-shaft, the rotating hook-shaft, the cam thereon, the rock-shaft, the tappet on the rock-shaft actuated by the cam, the feed-wheel rotating about the hook-shaft, and its frictional clutch-connections actuated by the rock-shaft upon each revolution of the cam, for the purpose described.

4. The combination of the intermittently-operated rock-shaft, its toe, the feed-wheel, its disk or ring, the griper mounted in a slot therein, its spring, the stop-pins on said disk, the adjusting-bar acting upon one of said pins, and the spring bearing upon the other, these members being constructed and operating substantially as hereinbefore set forth to adjust the feed.

In testimony whereof I have hereunto subscribed my name.

JAMES ALFORD HOUSE.

Witnesses:

FREDK. L. HEARSON,
CHAS. H. DIMOND.