

C. H. NYE.
Car-Brake.

No. 210,050.

Patented Nov. 19, 1878.

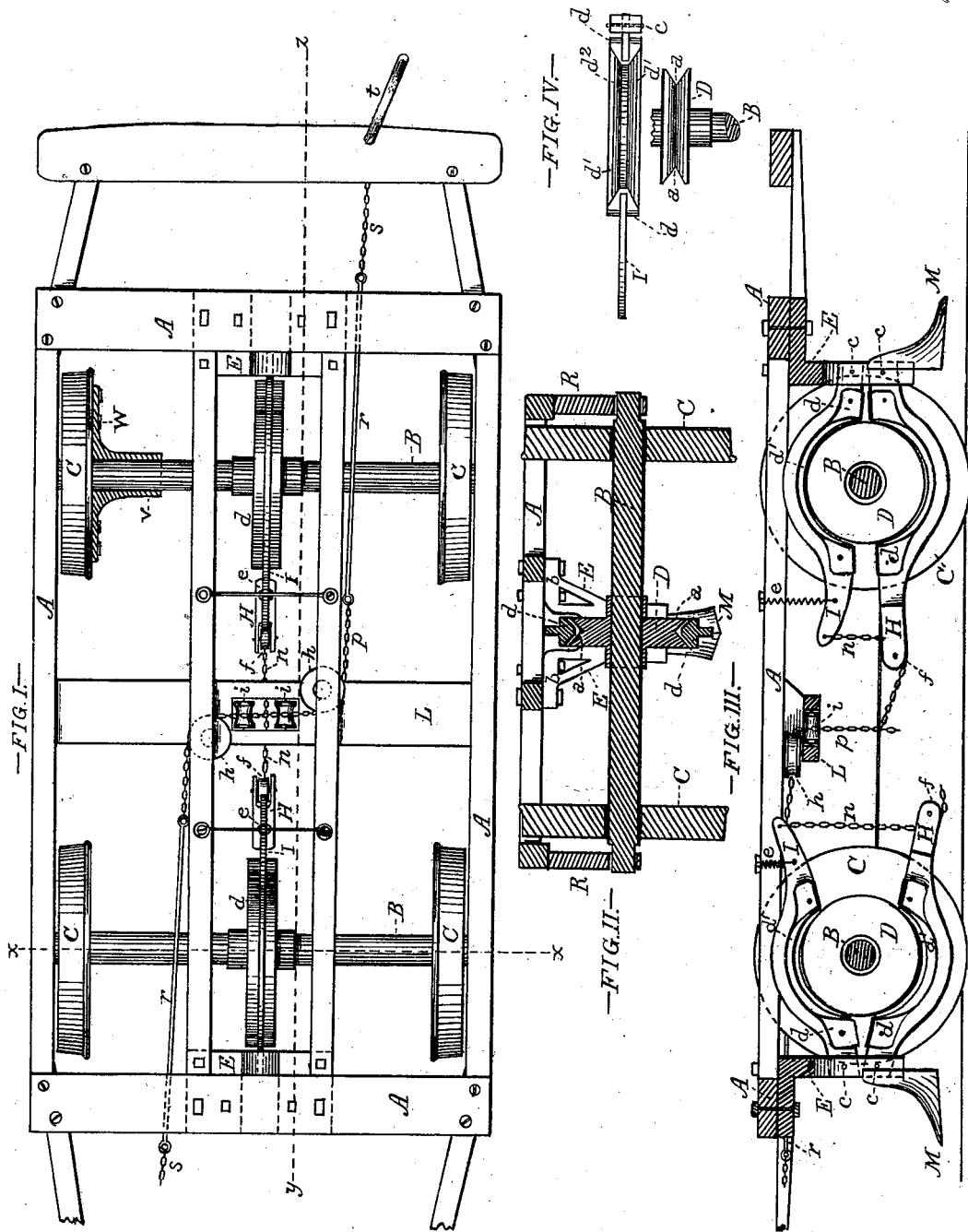

Witnesses:

Chas. C. Lewis
A. C. Eader

Inventor:

Chas. H. Nye
By his Atty.
Chas. B. Mann

UNITED STATES PATENT OFFICE.

CHARLES H. NYE, OF BALTIMORE, MARYLAND, ASSIGNOR OF ONE-HALF HIS RIGHT TO CHARLES H. STEVENSON, OF SAME PLACE.

IMPROVEMENT IN CAR-BRAKES.

Specification forming part of Letters Patent No. **210,050**, dated November 19, 1878; application filed April 27, 1878.

To all whom it may concern:

Be it known that I, CHARLES H. NYE, of Baltimore, in the county of Baltimore and State of Maryland, have invented a new and useful Improvement in Car-Brakes, of which the following is a specification:

My invention relates to an improvement in car-brakes of the class in which a special brake-wheel is secured to the axle, and is applicable either to steam railroad or horse cars.

The invention consists in a novel construction and arrangement of the brake-levers and their operating-chains for applying the brake-shoes to the wheels, as hereinafter described.

Figure 1 is a plan view of the bed-frame of a car embodying my improvements. Fig. 2 is a section view through $x x$, Fig. 1, as seen toward the near end of car. Fig. 3 is a vertical longitudinal section through $y z$. Fig. 4 is a detached view of one of the brake-levers and brake-wheels.

A represents the frame of a car or truck; B, the axles; C, the wheels; R, the journal-boxes. Upon the center of the axles is secured a brake-wheel, D, in the rim of which is formed a V-shaped groove, a . To the under side of frame A, and close to the brake-wheel on the side next to the near end, is secured a stanchion, E, the upper part being bifurcated, as shown at $b b$, and secured to the frame. To this stanchion the end of the lower brake-lever, H, and upper brake-lever, I, are secured by bolts c . To each lever is attached a brake-shoe, d , having beveled sides d' , of the same pitch as the sides of the V-shaped groove on the brake-wheel. These beveled sides join the flat face d^2 . Thus formed, the shoe will fit the groove of the wheel, and has the advantage of bearing on the wedge principle.

To the free end of lever I a spring, e , is attached and secured to the frame or car, serving to relieve the pressure of the shoe when the brake is released. To the free end of lever H a sheave, f , is attached. In the center of cross-beam L is a mortise, in which is secured two friction-rollers, $i i$, and on the upper side are two sheaves, $h h$. Instead of the cross-beam L, as shown in the drawing, the rollers i and sheave h may be secured to a plate of cast-iron affixed to the central part of the frame.

One end of the chain n is secured to the free end of the upper brake-lever, I, and thence passes around sheave f in the end of lower brake-lever, H, and thence passing across to the other brake-levers, where it is arranged and the end secured in the same manner. A chain, p , connects with chain n , as shown, and, passing over the friction-rollers i and around sheave h , is attached to the rod r , from the other end of which a chain, s , connects with the brake-staff t . The same arrangement is made with another chain, p , to connect with the brake-staff on the other end of car, in order that the brake may be applied from either one or both ends, at one and the same time, if desired.

At each end of the car, and attached to and in front of the stanchion E, is the clearing-pilot M, which is designed for use only on street-cars, the object of which is to clear the way of obstructions, especially snow and ice during the winter season.

Should it be deemed necessary to provide additional means for securing the wheels C to the axles, a re-enforcing flange, W, may be used of a size to extend well over the side of the wheel, to which it is bolted, and having a sleeve, V, to fit the axle, to which it is keyed or otherwise secured.

It will be seen that when the brake is applied through the medium of the crank on the brake-staff, the chains draw on all the brake-levers, causing the shoes to clamp the brake-wheels alike on opposite sides, thus obviating the difficulty commonly occasioned by brake-shoes pressing against the wheel altogether on one side, which causes undue wear on the bearings or boxes; and the arrangement of the chains is such that the brakes may be applied with double effect by persons at each end of the car simultaneously turning the crank.

Having described my invention, I claim—

In a car-brake, the brake-wheel D, secured to the center of the axle, brake-levers H I, the ends of which are secured to the stanchions E, and having the brake-shoes d to clamp the wheel on opposite sides, chains n and p , friction-rollers, and brake-staff t , arranged and constructed as herein shown and described.

In witness whereof I hereunto sign my name.

Witnesses: CHARLES H. NYE.
CHS. E. LEWIS,
JNO. S. MADDOX.