

M. T. BAILEY.  
Grate.

No. 210,077.

Patented Nov. 19, 1878.

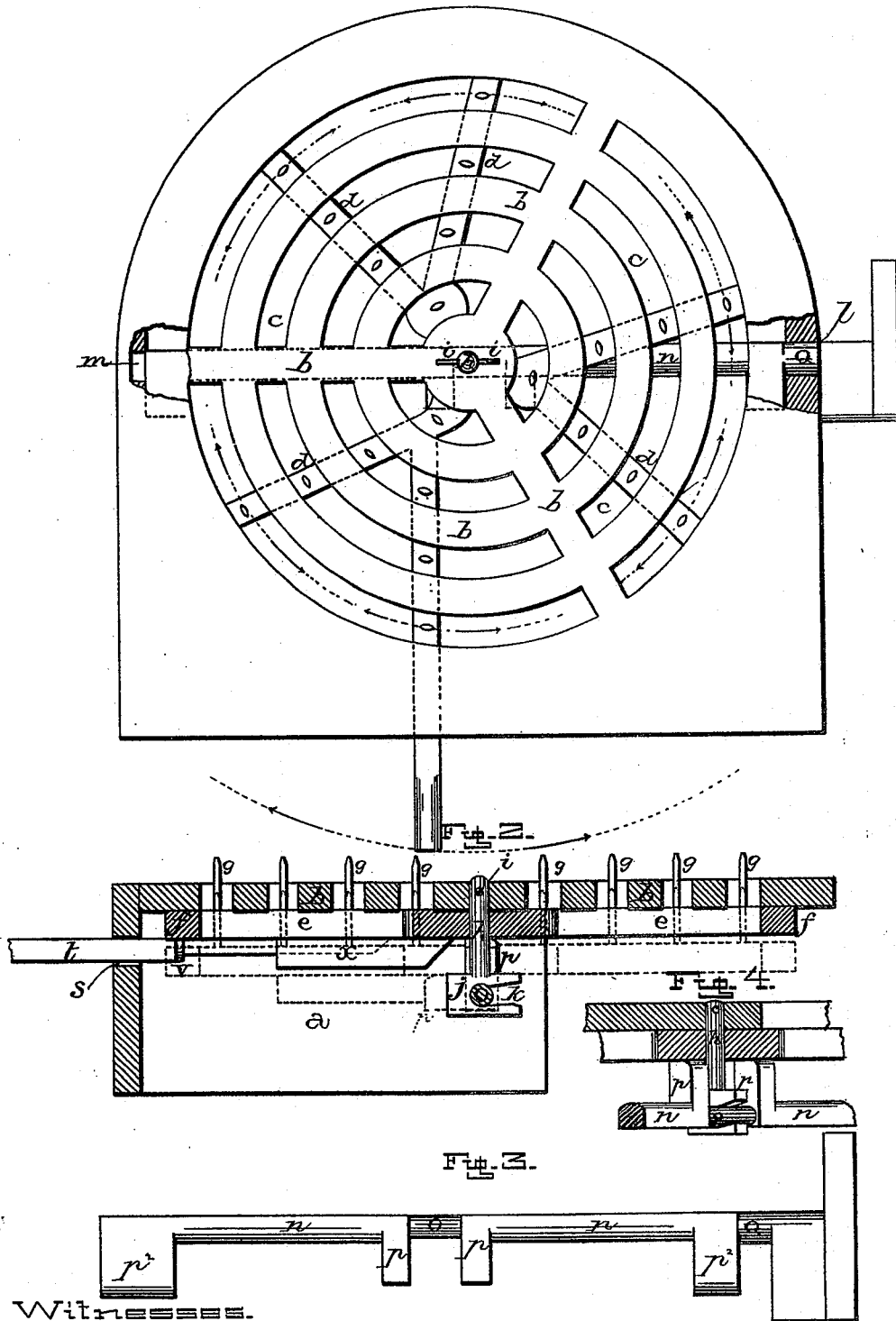

Witnesses.

*J. W. Garner*  
*W. S. D. Gaines*

Inventor.  
*M. T. Bailey*  
per  
*J. C. Lehmann atty.*

# UNITED STATES PATENT OFFICE.

MILTON T. BAILEY, OF PHILADELPHIA, PENNSYLVANIA.

## IMPROVEMENT IN GRATES.

Specification forming part of Letters Patent No. 210,077, dated November 19, 1878; application filed May 25, 1878.

*To all whom it may concern:*

Be it known that I, MILTON T. BAILEY, of Philadelphia, in the county of Philadelphia and State of Pennsylvania, have invented certain new and useful Improvements in Grates; and I do hereby declare the following to be a full, clear, and exact description of the invention, such will enable others skilled in the art to which it pertains to make and use it, reference being had to the accompanying drawings, which form part of this specification.

My invention relates to an improvement in rakers for grates; and it consists in the arrangement and combination of parts, whereby the ashes may be removed in a rapid and effectual manner and the fire left in a porous condition, instead of shaking it down upon the grate in a solid mass, as will be more fully described hereinafter.

Figure 1 is a plan view of my invention. Fig. 2 is a vertical section of the same, and Fig. 3 a detail. Fig. 4 is a detail perspective.

*a* represents the ash-pit, which may be of any desired shape, size, or construction, upon the top of which is placed the grate *b*, which consists of the circular and radial bars, as shown. Between the circular bars are formed the circular slots *c*, the lengths of which are determined by the radial rods or bars. Under this grate is pivoted the raker *d*, which consists of a series of arms, *e*, the outer ends of which are joined together by the ring *f*, and from the tops of these arms *e* project a series of suitably-shaped sharp-pointed projections, *g*, which are arranged in such relation to the slots *c* that when the raker is pressed upward against the grate the projections will project a suitable distance above the top of the grate into the fire and ashes upon it. This raker is pivoted upon and is vertically adjustable upon the center-pin *h*, which passes down through the center of the grate, and is supported in position by means of a pin, *i*, which is recessed in the top of the grate. Upon the lower end of this pin is formed an enlarged head, *j*, which has a slot, *k*, formed in one side, and which head prevents the raker from descending too low.

Through one side of the ash-pit is made a suitably-shaped hole, *l*, and in the inner side of the opposite side of the pit is made the recess *m*. Passing through the hole *l*, and ex-

tending across the pit so that the inner end will catch in the recess *m*, is the elevator-rod *n*, which is given a suitable play back and forth. The center of this rod is reduced in size, as shown at *o*, so as to fit in the recess *k*, and on each side of the head *j* is formed a shoulder, *p*, which acts as a stop to prevent the rod from being displaced.

Near the outer end of the rod *n*, upon which the operating-handle is formed, the rod is again reduced in size for just sufficient distance to make the shoulders on each side fit down over the side of the pit. When the rod *n* is drawn outward until the reduced part *q* rests upon the side, the inner end of the rod is drawn out of the recess *m* in the pit, when the rod can be turned freely around.

Upon the same edge of the rod as the shoulders *p* are formed the two shoulders *p*<sup>2</sup>, which are just far enough apart to fit under the ring *f* on opposite sides, so that when the rod is turned these shoulders raise the raker upward against the under side of the grate, so that the projections *g* will project up through the slots *c*.

After the raker has been raised upward, if it is desired to retain it there for any length of time, the rod *n* is pressed inward, so that its end will catch in the recess *m*, when it cannot turn.

Through the front of the ash-pit is made the horizontal slot *s*, through which a lever, *t*, is passed, so that its end will catch in the staple or loop *v* and socket *x* formed on the under side of the raker.

When it is desired to rake the ashes out the elevating-rod is turned half-way around, so as to cause the shoulders to raise the raker upward, and then the rod is pressed inward, so that the inner end catches in the recess *m*. While thus pressed inward, holding the raker upward, the outer end of the rod closes the hole *l*, so that no ashes can escape at this point. By moving the lever *t* from side to side, the raker is made to revolve back and forth, so that the projections *g* will rake out the ashes and pulverize the clinkers and cinders, leaving the fire in a porous condition, instead of shaking it down in a solid mass upon the grate. When the ashes have been cleaned out the rod *n* is drawn outward and turned half-way around, thus leaving the raker free to drop downward,

so that the projections will not be injured by the fire.

Having thus described my invention, I claim—

1. The combination of a grate and a raker, the raker being made vertically adjustable and to turn freely upon its pivot, so that after it has been raised upward it can be used to clean out the ashes and cinders, substantially as shown.

2. The combination of a grate having the circular slots *c* with the raker *d*, having the projections *g*, and a rod or other suitable device for raising the raker upward, substantially as described.

3. The center-pin *h*, having the head *j* and slot *k*, in combination with the raker and grate, substantially as set forth.

4. The combination of the raker, the center-pin, and the rod *n*, having the shoulders *p*<sup>2</sup>, substantially as specified.

5. The combination of the pit *a*, having a hole, *l*, on one side and a recess, *m*, on the other, with the rod *n* and raker, the rod having both a rotary and an endwise movement, for the purposes substantially as shown.

6. The combination of the pit *a*, grate *b*, center-pin *h*, having head *j* and slot *k*, rod *n*, having the shoulders *p*<sup>2</sup>, the hole *l* in one side of the pit, and a recess in the other for the rod *n* to fit in, all being arranged and combined to operate substantially as described.

In testimony that I claim the foregoing I have hereunto set my hand this 21st day of May, 1878.

MILTON T. BAILEY.

Witnesses:

JNO. R. FENNER, Jr.,  
FRANCIS S. CANTREL.