

J. C. MACK.

Pumps for Ice and Refrigerating Machines.
No. 210,134. Patented Nov. 19, 1878.

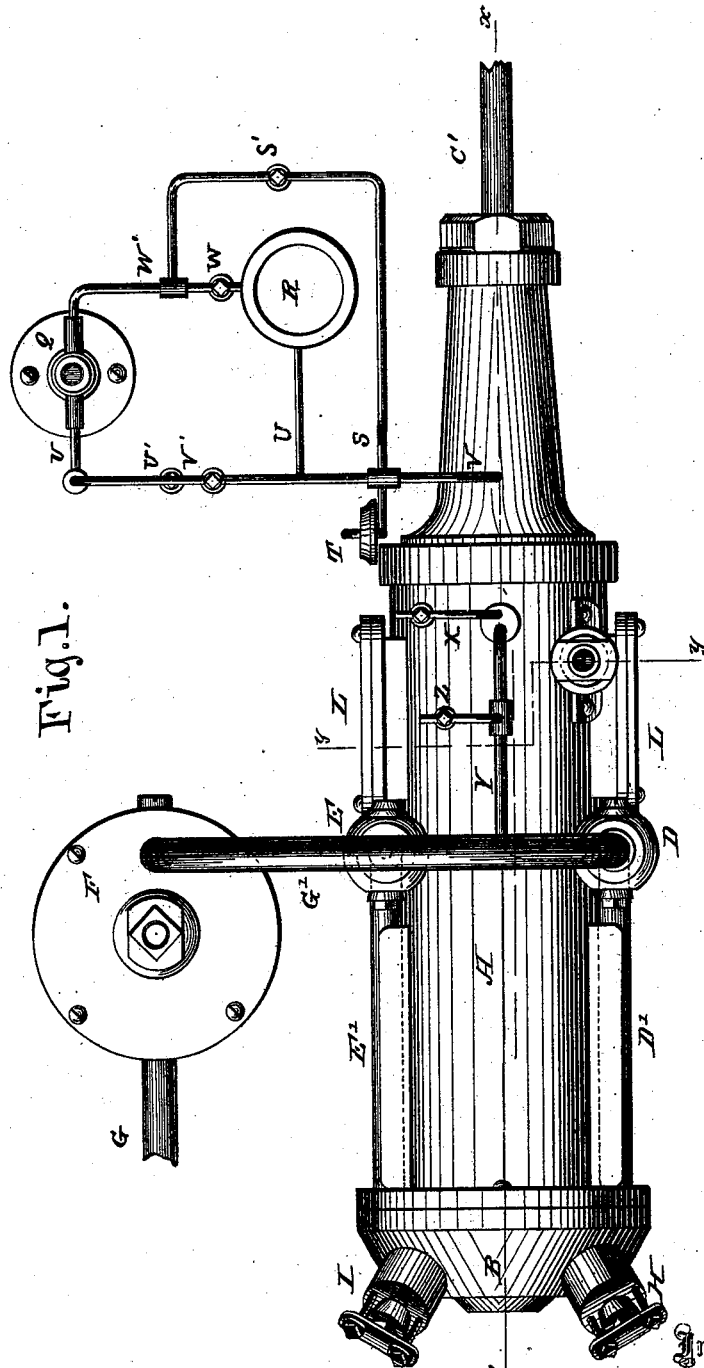

Fig. 1.

Witnesses:

P. C. Weston
R. A. Dyer

Inventor:

J. C. Mack

J. C. MACK.
Pumps for Ice and Refrigerating Machines.
No. 210,134. Patented Nov. 19, 1878.

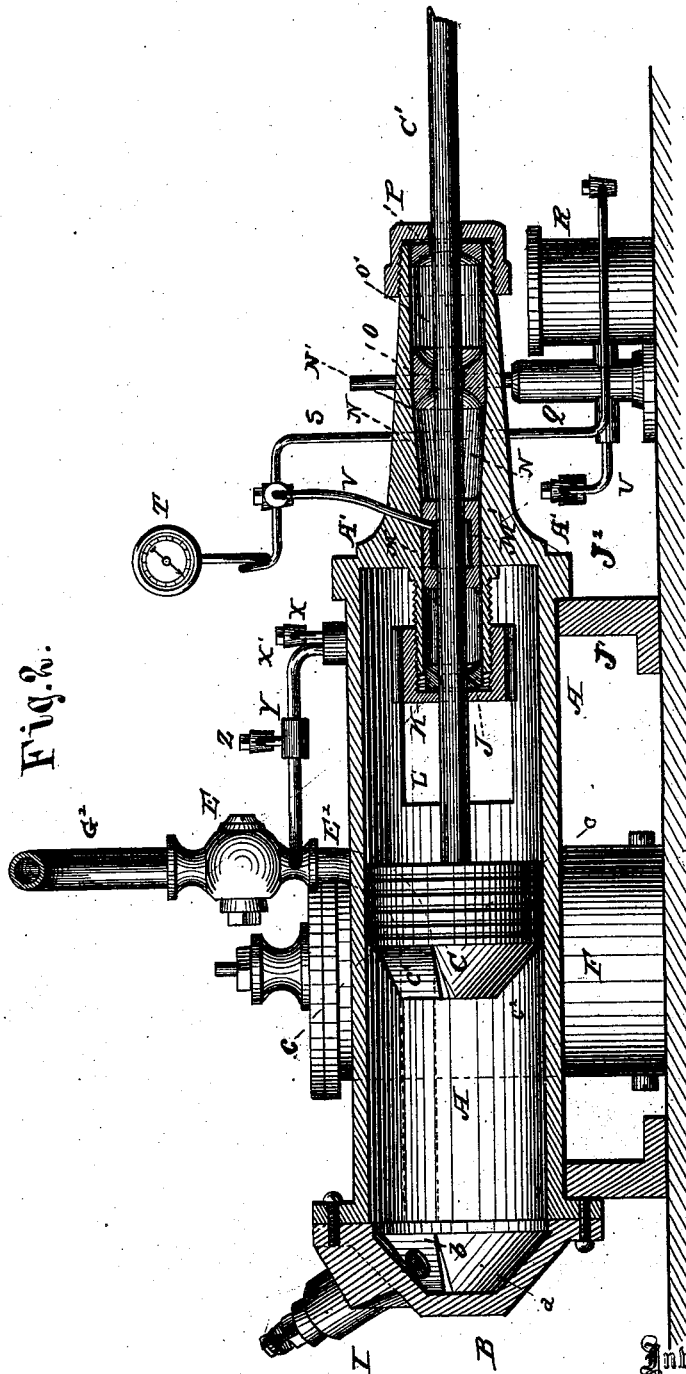

Fig. 2.

Witnesses:

P. C. Dietrich.
R. A. Dyer.

Inventor:

James C. Mack

J. C. MACK.
Pumps for Ice and Refrigerating Machines.
No. 210,134. Patented Nov. 19, 1878.

Fig. 3.

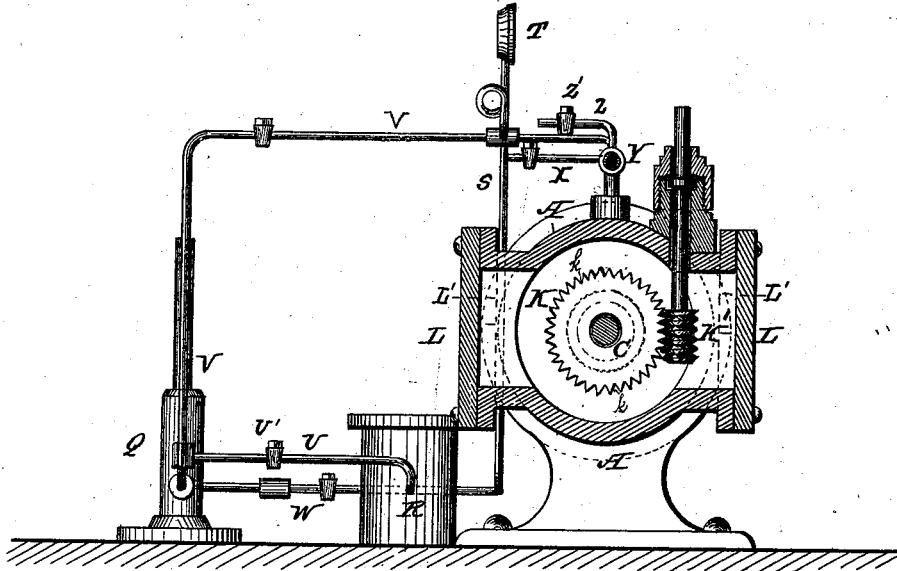

Fig. 4.

Fig. 6.

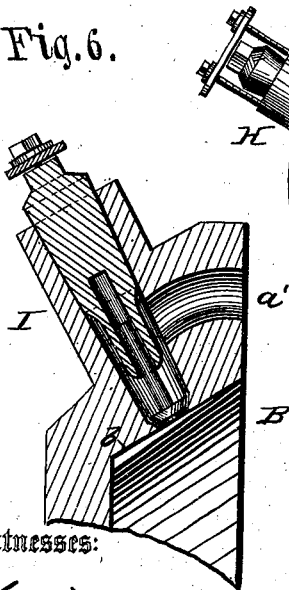

Fig. 5.

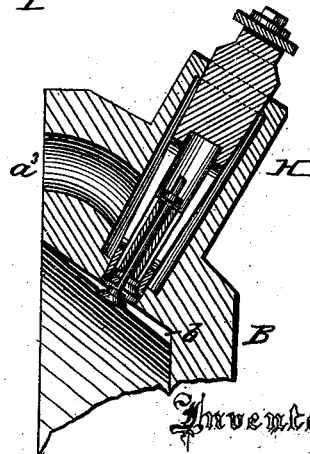
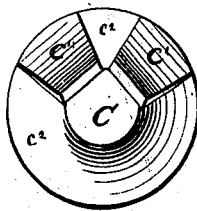

Fig. 7.



Witnesses:

P. C. Dietrich.
R. N. Dyer.

Inventor:

James C. Mack

UNITED STATES PATENT OFFICE.

JAMES C. MACK, OF BROOKLYN, NEW YORK.

IMPROVEMENT IN PUMPS FOR ICE AND REFRIGERATING MACHINES.

Specification forming part of Letters Patent No. **210,134**, dated November 19, 1878; application filed February 21, 1878.

To all whom it may concern:

Be it known that I, JAMES C. MACK, of Brooklyn, in the county of Kings and State of New York, have invented a new and useful Improvement in Pumps for Ice and Refrigerating Machines; and I do hereby declare that the following is a full and exact description of the same, reference being had to the accompanying drawings, and to the letters of reference marked thereon.

The object I have in view is, mainly, an improvement in pumps employed in forcing by mechanical means a circulation of volatile refrigerants, especially ammoniacal gas, into machines intended for the manufacture of ice, and for other refrigerating or cooling purposes, and thereby aiding in the subsequent liquefaction of said gases; and my apparatus is so constructed as to avoid the defects and inconveniences now found objectionable in such pumps. These defects and inconveniences which I wish to avoid or overcome may be briefly described as follows, viz: First, the liability of leakage of gas; second, the introduction of air and water into the pump; third, the inability of the pump to force out all the gas at every stroke of the piston; fourth, the liability of the pump to heat in use, all of which arise from a faulty construction and arrangement of the pump, its valves and valve-seats, and its packing.

The novelty of my invention consists, mainly, in the construction and arrangement of the internal stuffing-box; in the peculiar construction of the valve-seats; in the means employed for the supply and regulation of the lubricator; in the means for the application of the lubricator to the internal stuffing-box; in the means for adjustment of the internal stuffing-box; and in the various operative combinations of its principal parts, all as more fully hereinafter explained.

In order that those skilled in the art may know how to make and use my apparatus, I proceed to describe the same, having reference to the accompanying drawings, in which—

Figure 1 is a top view of my apparatus; Fig. 2, a central vertical section on line *x x* of Fig. 1; Fig. 3, a cross-section on line *y y* of

Fig. 1; Fig. 4, a view of the inside of the pump-head, showing also the valve-seats. Figs 5 and 6 are sections through the valves in the pump-head; and Fig. 7, an end view of the front end of the piston.

Like letters denote corresponding parts in each figure.

In the drawings, A represents the pump-cylinder, made of any proper material; and A', the neck, which may be made solid with the cylinder, or may be a separate part, adapted to be secured to the cylinder proper in any convenient manner. It will be observed that this cylinder is to be supported in any proper way, upon any suitable bed, in a horizontal position, although it is apparent that without invention the attachments to my pump may be arranged so that the pump may be operated when in a vertical position or at any angle of inclination.

B represents the pump-head, designed to be secured to the cylinder in any usual or convenient manner, which head is recessed or hollowed out, as at *a*, to correspond with the construction of the piston-head C in the form of the frustum of a cone, except at *b b*, where the recess *a* is cut away at a less angle than the remainder of the recess into rectangular seats in direct lines without curvatures, intended to correspond closely with similar projecting faces *c' c'* upon the piston-head. These rectangular seats enable the valve to be pitched several degrees nearer to the perpendicular, and serve as cavities, into which the gas impelled by the forcing action of the piston within the recess *a* is collected, and out of which it is forced by the piston into the valve-opening *b'*, and to serve as exact face-lines for the faces of the valves *b³ b⁵*, and as seats for the faces *c' c'* in the piston-head.

It is apparent that if the valves *b³ b⁵* entered directly into the recess *a* with its circumferentially-curved lines, and the valve-faces were made convex to correspond, it would be inconvenient to fit them to the seats or grind them tight or otherwise properly adjust them.

Any complications of springs or guides would cause the valves to work hard, and not operate

automatically by pressure and gravity alone, which is quite an essential condition in my apparatus.

The valves b^3 b^5 , of which the first is the inlet and the last the outlet, are arranged at right angles with the faces of the rectangular seats, so as to present their flat faces to the flat seats. The inlet-valve stem passes through a three-winged guide within a cone-shaped plug, and is secured by nuts or their equivalents on the top of the guides. The valve has the necessary freedom of movement within the plug. The plug has suitable openings into its interior, and is fitted into a conical bearing, having a chamber around its central part to enable the gas to circulate round it and fill all the openings in the plug. A passage, a^1 , serves as a conduit to the plug on the inlet side from the interior of the supply-pipe D' , hereinafter described at a^2 ; and a similar passage, a^3 , serves as a conduit from the plug on the outlet side to the outlet-pipe E^1 , hereinafter described. The conical plugs shown by the letters H and I are turned tapering within the angle of friction, and are ground gas-tight into their seats in the piston-head of suitable metal. The head is chambered out for lightness, and upon its periphery are grooves e , adapted to hold a packing, preferably metallic, and has a face, c^2 , like the frustum of a cone, adapted to fit closely into the recess a , and other projecting flat faces, c^1 , adapted to fit accurately into the seats b b .

If, now, in the operation of the pump the piston-head is moved into the head of the pump for the purpose of forcing out gas, the gas is compressed into the recess a and into the rectangular seats b b , and out of the valve-opening b^4 , and through the connecting-passage a^3 , into the outlet-pipe; and when the piston-head is withdrawn the gas from the inlet or supply pipe enters through the passage a^1 into the plug, and thence through the opening b^2 into the interior of the cylinder.

To shut off the movement of gas, I employ an ordinary cock, D, on the inlet side of the pump, and a similar cock, E, on the outlet side. The inlet-pipe D' , passing along preferably close to the inside of the cylinder, connects with the passage a^1 , and from the cock D another pipe, G' , passes into the separating-chamber F at or near the top of the same. The outlet-pipe E' , having a connection with the passage a^3 , leads along, preferably upon the outside of the cylinder, to the cock E, and thence to the condenser. (Not shown in the drawings.)

The office of the separating-chamber F, which is a suitable vessel, having a gas-tight partition across its lower part, in which a hygroscopic is deposited, so arranged that when the hygroscopic becomes hydrated it may be removed and renewed without stopping. The duty of the apparatus is to store the gas, so as to present to the pump a continuous supply, and has also means for drying the gas, if necessary, and also a pipe, G, which leads from

the congealer. This chamber, however, is not more fully described here, as it is intended to make it the subject of a distinct application for Letters Patent.

For the better operation of my pump I employ certain features connected with packing and lubrication, which I now proceed to describe. The piston-rod C' first passes through the independent stuffing-box J in the interior of the cylinder A, which box J is composed of a cylinder made of suitable metal, with its periphery K grooved longitudinally, as at k , so as to engage with a worm-gear, K' , whose shaft is vertically arranged, and passes out through a suitable stuffing-box, and has at its upper end some convenient means for turning it. Instead of the worm-gear, other equivalent gearing may be used.

A follower-ring, J^1 , may be used upon the the interior of the stuffing-box. This stuffing-box is screwed upon the neck J^2 , which has a cylindrical opening of uniform size, extending as far as the stationary hollow bushing M, which has a chamber, M' , for receiving mineral oil as a lubricant. In this opening or chamber, or space between the hollow bushing M and the interior of the stuffing-box, I propose to use soft pliable packing, preferably such as cotton fiber and the like, which are in the market.

L L are plates to cover the hand-holes $L' L'$, closed gas-tight, and secured in any proper way, which holes are for the purpose of giving access to the interior of the cylinder at a point convenient to the interior stuffing-box.

The object of the interior stuffing-box and its worm-gear, operated from the outside, is to enable the operator, by turning the shaft of the worm-gear, to screw up the stuffing-box, thus compensating for the wear of the soft packing, and keeping the piston-rod securely packed to prevent the escape of gas or the entrance of oil into the cylinder. Next after the bushing M the piston-rod passes through the packing-space N, which tapers regularly toward the bushing, and extends thus tapering as far as the point N' , where there is placed the double-cupped loose gland O. This gland, through which the piston-rod passes, is recessed or cupped at each end, so that the soft packing which is employed at each end is crowded into such recesses, and the piston-rod is thereby packed more securely. Next to this gland O is another packing-space, O' , which is to be filled with soft fibrous packing.

The external stuffing-box, P, having preferably a following ring within it, is screwed lightly upon the neck A' , and the piston-rod outside, when necessary, is kept moistened with water or oil.

By screwing up the packing-box P the packing in the space O' is forced along, in turn forcing the gland O along, which, in turn, forces the packing into the tapering space N, and thus the wear of the packing is taken up conveniently.

For the supply of the lubricating-oil the

pump Q is employed, which has connection, by a suitable pipe, V, with the stationary hollow bushing M. This pump serves also for withdrawing the oil or air from the same hollow bushing.

R is an oil-reservoir, connected with the pump by a suitable pipe, W. On the pipe V is a cock, V'. On the pipe W is a cock, W'. From the pipe W proceeds a pipe, S, having upon it a cock, S'.

Another pipe, U, leads from the pipe V into the oil-reservoir R, and this pipe U has a cock, U'. A pressure and vacuum gage, T, is connected by a suitable pipe to a cross-coupling, where the pipe S joins the pipe V.

When it is desired to furnish oil to the hollow bushing M, the cocks W' and V' are opened, and the cocks S' and U' closed, and the oil is drawn directly from the reservoir through the pump and pumped into the hollow bushing M. When the cocks W' and V' are closed and the cocks S' and U' opened the pump then draws the oil and air also from the hollow bushing along the pipe V to the pass-over pipe S, along this pipe to the pipe W, then into the pump, then along the pipe U into the reservoir. The pressure and vacuum gage T shows the condition of pressure or vacuum at M, as it has a free open communication with the pipe V, and the pressure in this pipe is the pressure in the bushing M, and so in like manner the vacuum in the bushing M is shown by the gage.

As the pump-cylinder is liable to heat, particularly when started, I employ a system of appliances to cool the same, which I thus describe: A small pipe, X, of about one-eighth of an inch internal diameter, leading from the receiver (not shown) or other supply of liquefied ammoniacal gas, is tapped into the cylinder near the neck end of the same, has on it a cock, X', which allows a small flow of liquefied gas to enter the cylinder. This liquefied gas evaporizes immediately and absorbs heat, and keeps the interior of the cylinder near J and the piston-rod cool. After performing this duty the gas passes into the inlet side of the pump through Y, as shown. After the cold gains upon the congealer the cock X' is shut, but the pipe Y is left open to destroy the vacuum behind the piston and create a back-pressure. A water-jacket may be used on the cylinder; but a stream of water on head B will keep down all violent heating caused by the action of the piston upon the gas.

The mode of operation of my pump may be described as follows, viz: The back-stroke of pump-rod creates a vacuum behind the piston, which causes the inlet-valve to open, and the gas from inlet-pipe D' and chamber F, connecting to congealer (not shown) by pipe G, is drawn into the pump. Now, upon the return stroke of the piston the inlet-valve closes, preventing the escape of the gas back through the inlet-valve H. The pressure in the pump opens the outlet-valve I, and the gas is forced into the condenser, (not shown,) which may

be a coil of pipe immersed in running water, and there the restored or sensible heat evolved by the action of the piston on the gas is carried off, and under the forced pressure of the pump the gas is liquefied. A receiver (not shown) contains this liquefied gas, and from thence it is conducted by a small tube (not shown) to the congealer, (not shown,) where the main effect of the evaporation is to be produced.

When it becomes necessary to renew the packing between the parts M and P, the pump A is stopped, the internal stuffing-box, J, tightly screwed up from the outside, and the oil in the part M' is pumped out into the oil-reservoir R. After the packing has been renewed the pump Q is to be worked until the gage T shows a vacuum of at least twenty inches. The bushing M is then to be charged afresh with oil from the oil-reservoir.

When it is desired to repack the internal stuffing-box J, the plates L' L' are removed, and, the packing being renewed and the plates restored to place, the pump must be purged of air, which may be done by opening the cocks Z' and X', and also, if need be, the cocks E and D, so as to allow the cylinder to fill with gas when the cocks Z' and X' are closed.

I prefer to use mineral oil as a lubricant in the part M', because it is a superior lubricant, and is not affected by the alkaline properties in ammonia.

Should it be deemed desirable to place the pump vertically—as, for instance, in small machines—the inlet-valve can be placed in the piston-head, and reached through the hand-holes, and the outlet-valve vertically in the head.

Should it be desirable, flexible packing-rings may be used upon the piston, which can be adjusted through the hand-holes.

The advantages of arranging the pump in a horizontal position consist in economy of space, making the same adapted particularly for vessels, stability upon foundation, ease of access, and greater cheapness of construction and of repair.

The advantages of the system and means for packing and for lubrication are apparent upon inspection. It is to be observed, however, that this system and means for packing may be applied to a pump with a rotary shaft, as well as to a pump with a reciprocating piston-rod.

I propose to drive this pump direct by a steam-engine, the cylinder of the engine being on a line with the cylinder of the pump, the engine being a half-trunk piston-engine, designed to give full pressure of steam upon one side in a gradually-increasing pressure and a much smaller pressure upon the other side, upon which engine I intend to make application for Letters Patent.

It is evident that any other engine or suitable power may be used to drive this pump, a fly-wheel being necessary to govern speed and insure regularity of stroke.

Having thus described my apparatus and its

method of use and some of its advantages, what I claim as new therein and of my invention is—

1. In a pumping apparatus for ice-machines, the internal stuffing-box, J K, grooved upon its periphery and adapted to be turned by external means, substantially as and for the purposes described.

2. In a pump, the piston-head C, with the faces $c^1 c^1$, substantially as described.

3. In combination with the solid fixed chambered bushing M, the pump Q and connecting-pipes, whereby oil is forced into said bushing or air exhausted from the same, substantially as described.

4. In a pump, a worm or equivalent gear, operated from the outside, for adjusting an internal stuffing-box, substantially as described.

5. In a pump, a pump-head having a curvilinear recess and flat recesses, substantially as described.

6. The combination of the oil-pump Q and reservoir R with the pipes V, W, S, and U and their cocks, substantially as and for the purposes described.

7. The combination of the cylinder A with the pipes X Y Z and their cocks, substantially as and for the purposes described.

8. The combination, with the inlet and outlet pipes, of the pipes X, substantially as and for the purposes described.

9. The combination, with the outlet and inlet pipes and their cocks, of the pipes Z and X and their cocks, substantially as and for the purposes described.

This specification signed and witnessed this 20th day of February, 1878.

JAMES C. MACK.

Witnesses:

L. W. SEELY,
R. N. DYER.