

P. NOYES.
Gas-Pressure Regulator.

No. 210,141.

Patented Nov. 19, 1878.

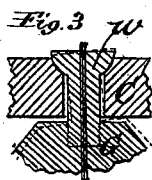
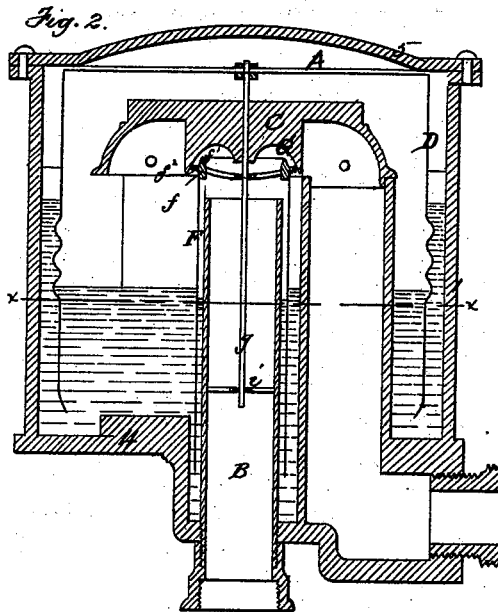
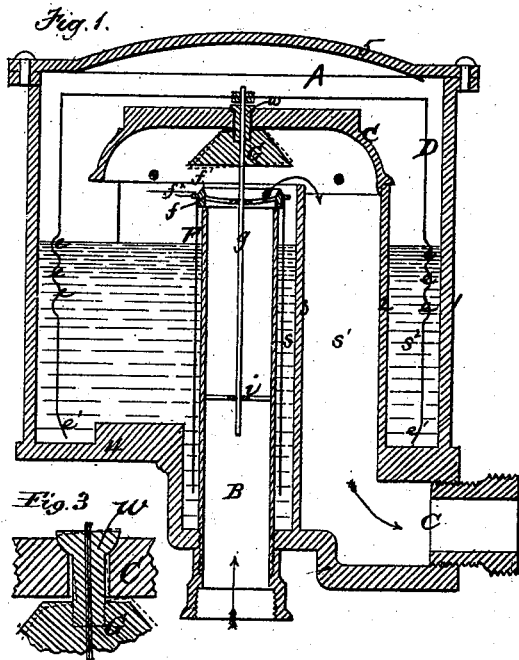
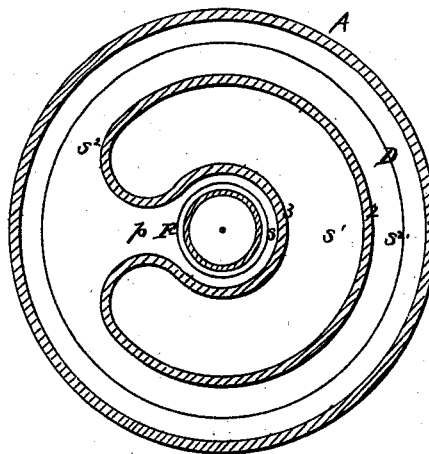

Fig. 4.



Witnesses.
C. F. Brown
W. Rosney

Inventor.
Person Noyes

UNITED STATES PATENT OFFICE.

PERSON NOYES, OF LOWELL, MASSACHUSETTS.

IMPROVEMENT IN GAS-PRESSURE REGULATORS.

Specification forming part of Letters Patent No. **210,141**, dated November 19, 1878; application filed May 6, 1878.

To all whom it may concern:

Be it known that I, PERSON NOYES, of Lowell, in the county of Middlesex and State of Massachusetts, have invented certain Improvements in Gas-Pressure Regulators, of which the following is a specification:

This invention relates to gas-pressure regulators employing as elements a floating gas-holder inclosed in a casing, and having suspended from it a valve, which closes upwardly against a seat, the holder, valve, and casing being so arranged that the gas can pass through the casing without obstruction until its pressure reaches a given point, when it will lift the floating holder and valve, and thus cause the valve to close on its seat and shut off the flow of gas through the casing.

My invention consists in certain improvements appertaining to the floating holder, the valve, and valve-seat, all of which I will now proceed to describe and claim.

Of the accompanying drawings, forming a part of this specification, Figure 1 represents a vertical section of a regulator embodying my improvements, showing the holder depressed and the valve open under a light pressure of gas. Fig. 2 represents a section, showing the holder and valve raised to shut off the flow of gas under a high pressure. Fig. 3 represents a vertical section, showing a portion of the tilting valve and of the dome. Fig. 4 represents a section on line *x x*, Fig. 2.

Similar letters of reference indicate corresponding parts.

A represents the casing of a gas-regulator, the same being composed of an outer wall, 1, two inner walls, 2 3, one within the other, a bottom, 4, cast with the walls, and a closely-fitting cover, 5, applied to the outer wall. The walls 1, 2, and 3 are concentric with each other; but the inner walls, 2 3, do not extend to the same height as the outer wall, and the wall 2 is provided at its upper end with a dome, *e*, which is suitably secured thereto, and is provided with perforations for the passage of gas.

B represents the pipe for the introduction of gas into the casing. This pipe enters the bottom of the casing, and extends to about the same height as the walls 1 2. Between the pipe B and the inner wall, 3, is a space, *s*, for

sealing-liquid. Between the walls 2 3 is a space, *s*¹, for gas, and between the walls 2 1 is another space, *s*², for sealing-liquid. The spaces *s s*² are connected by any suitable means, so that the liquid can flow from one to the other. This connection is preferably made by connecting the walls 2 3, so as to form a passage, *p*, between the spaces *s s*², as shown in Fig. 4.

C represents the gas-outlet which leads from the space *s*¹.

D represents the floating gas-holder, which is a cylinder of thin sheet metal, closed at its upper end and open at its lower end, and is arranged to float in the liquid in the space *s*², covering and inclosing the inner walls 2 3 and the dome *e* of the former. The holder is of uniform diameter from top to bottom, excepting at a point about midway between, where it is provided with a series of preferably three peripheral corrugations, *e e e*, and at its lower end, where it is bent inwardly to form an inclined flange, *e'*.

F represents the valve, which consists of a sheet-metal tube, open at both ends, and terminating at its upper end in a horizontal ring, *f*, which has an inverted-V-shaped or knife edge, *f*¹, and an outer flange or edge, *f*². The edge *f*¹ operates in connection with a flat valve-seat and the edge *f*² in connection with a concave seat, as described hereinafter. The ring *f* is provided with a cross-bar, to which is attached the rod *g*, that connects the valve with the floating holder, said rod passing through and sliding in an orifice in the dome C. The rod *g* also passes down into the tube below the ring *f*, and projects into the inlet-pipe B, which is provided with a fixed guide, *i*, consisting of a cross-bar having a hole, through which the rod *g* passes, and by which the valve is steadied and guided. The lower ends of the holder D and valve F project down into glycerine or other liquid, which is placed in the spaces *s s*².

G represents the valve-seat, which is located on the under side of the dome C, and is preferably of a conical form, with a flat base, which constitutes the seat, and is attached to the dome by a screw, *w*, screwed into its upper portion, said screw passing loosely into a hole in the dome, and having a head that bears

upon the upper surface of the dome. By this method of attachment the valve-seat is adapted to tilt slightly in either direction, and thus conform to any slight inclination of the ring *f* of the valve, so that the valve will always close tightly when it strikes the seat G.

Of the parts thus far described none constitute my invention, excepting, first, the corrugations *e* and the flange *e'* of the holders, and, secondly, the tilting valve-seat G.

The operation of a regulator having the parts described is as follows: The inlet B is connected to the outlet of a gas-meter and the outlet C to a pipe leading to the burners. The lower edges of the valve F and holder D are sealed by the glycerine in which they are immersed, so that no gas can pass below them, and the glycerine extends above the corrugations *b* on both sides when the holder is depressed, as shown in Fig. 1. The gas entering through the pipe B strikes against the dome C, and a portion passes through the perforations of the dome into the holder D, so that the pressure of gas in the holder is the same as that in the dome. As long as the pressure is light the holder and valve F remain depressed, and the gas passes freely from the pipe B through space *s'* and outlet C; but as the pressure increases upon the under side of the floating holder the latter is raised, and the suspended valve is brought so near its seat as to shut off the flow of gas so far as to reduce the supporting pressure below the holder until said pressure becomes equal to the downward pressure produced by the weight of the holder and its attachments. As the gas is drawn away from the regulator the pressure is relieved, and the holder and valve fall sufficiently to create a sufficient opening between the valve and its seat to permit the passage of the needed quantity of gas. It will be seen, therefore, that the holder rises and falls as the pressure varies.

The corrugations *e* and flange *e'*, when immersed in the glycerine, create friction, and thus cause a checking or governing action, which controls or governs the rate of the upward and downward movement of the holder, and prevents a too ready response on the part of the holder to slight variations of pressure, and also prevents sudden upward jerking of the holder under a sudden increase of pressure. The flange *e'* also acts particularly to prevent the holder from wobbling.

The rod *g* and guide *i* steady the valve in its movement and prevent it from coming in contact with the central pipe, B.

The tilting valve-seat G insures a perfect fit of the edge of the ring *f* of the valve against the seat, so that the flow of gas can be entirely stopped, whether the ring be exactly horizontal or otherwise.

The valve-seat on the dome may be rigidly attached to the dome, if desired, and may be hollowed or flat. When the valve-seat is hollow or concave it operates in connection with the flange or edge *f*² of the valve F, as shown in Fig. 2, and when the seat is flat it operates with the knife-edge *f*¹.

I claim as my invention—

1. In a gas-pressure regulator, the floating gas-holder D, provided with peripheral corrugations *e* and the inclined flange *e'*.
2. The valve-seat G, adapted to tilt on the dome *c*, combined with the valve F, substantially as described.
3. The valve-ring *f*, provided with the knife-edge *f*¹ and the outer flange or edge, *f*², as and for the purpose specified.

In testimony whereof I have signed my name to this specification in the presence of two subscribing witnesses.

PERSON NOYES.

Witnesses:

C. F. BROWN,
WM. ROSSNEY.