

J. ROSS.
Planing-Machine.

No. 21,499.

Patented Nov. 19, 1878.

FIG. 1.

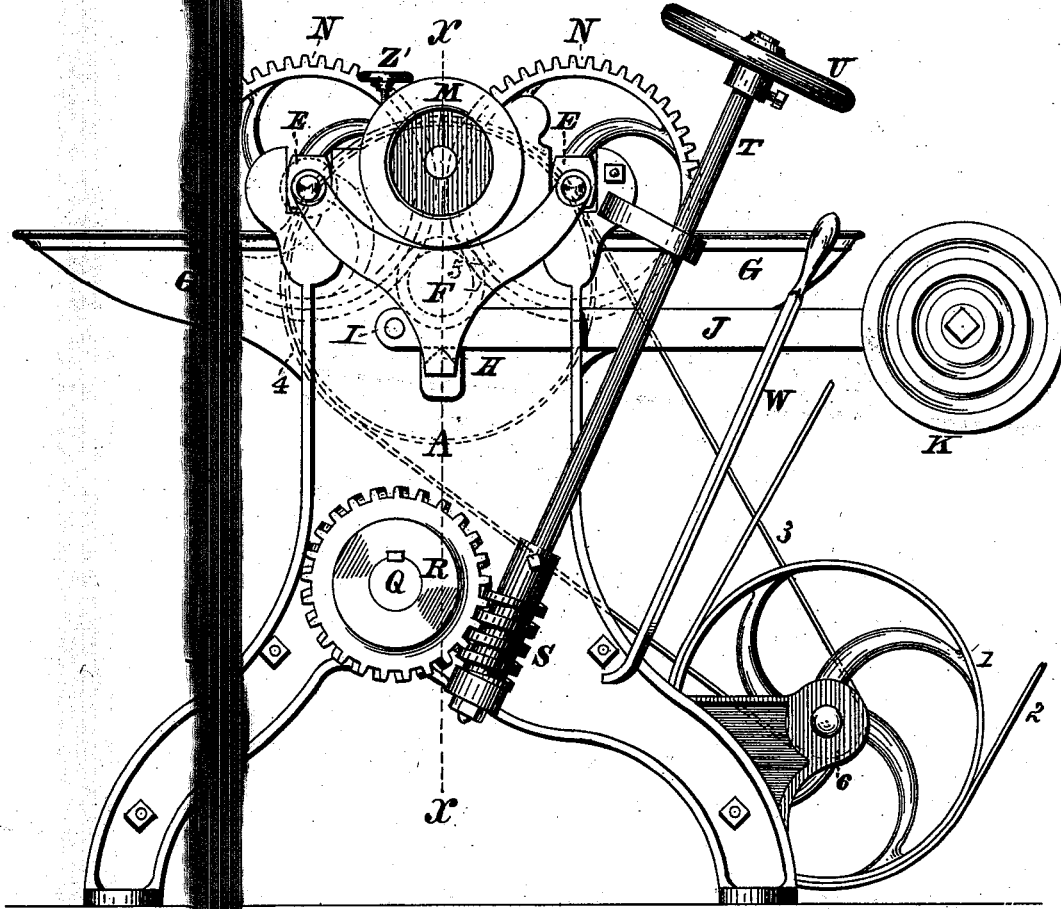
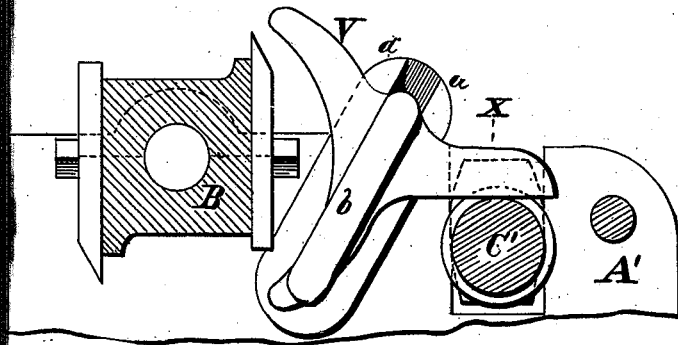

FIG. 2.



Witness:
 No. J. Stark
 J. Ross

Inventor:
 Josiah Ross,
 by Michael J. Stark atty

J. ROSS.
Planing-Machine.

No. 210,149.

Patented Nov. 19, 1878.

FIG. 3.

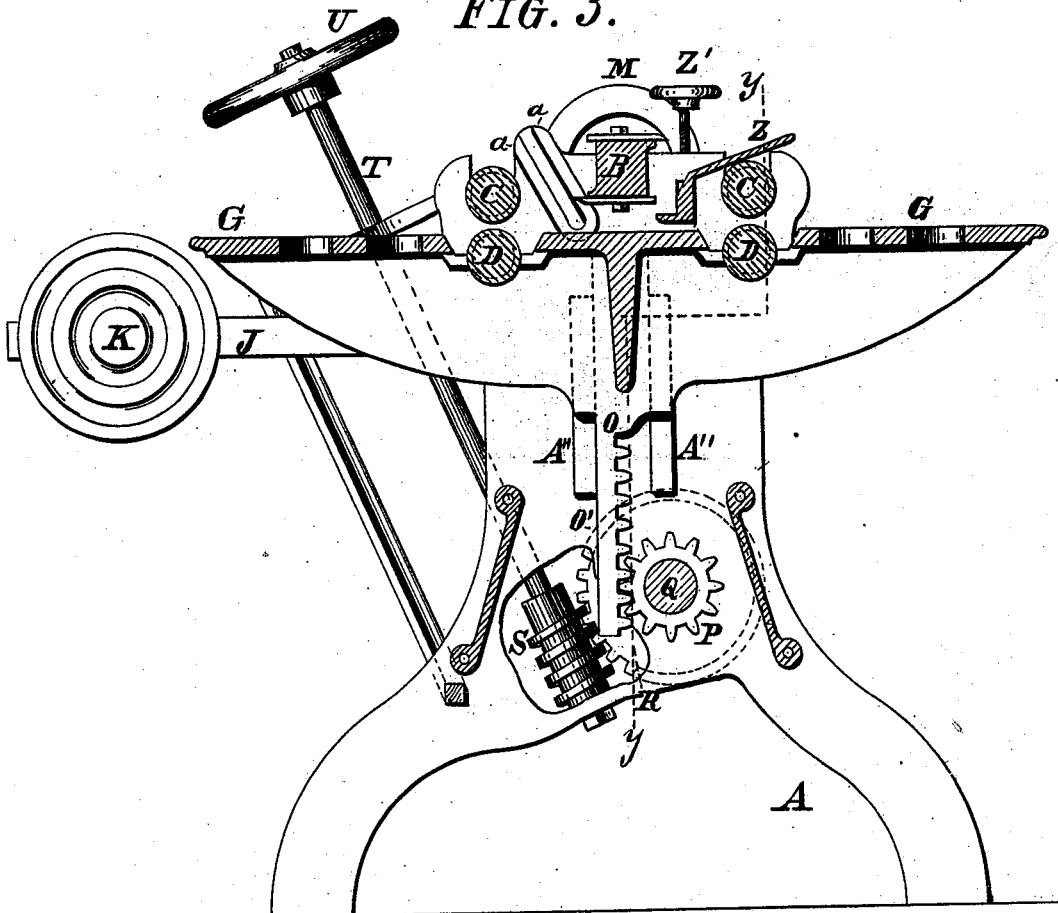
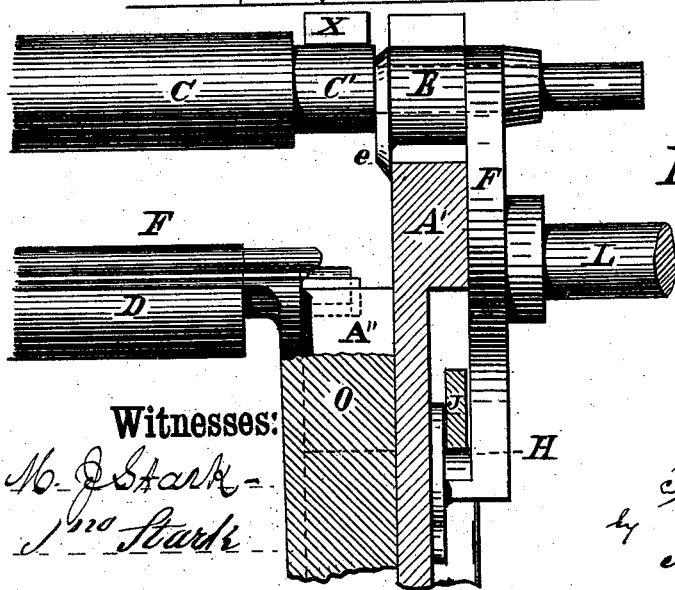

FIG. 4.



Witnesses:

*No. J. Stark -
J. Stark*

Inventor:

*Josiah Ross,
by Michael J. Stark atty.*

J. ROSS.
Planing-Machine.

No. 210,149.

Patented Nov. 19, 1878.

FIG. 5.

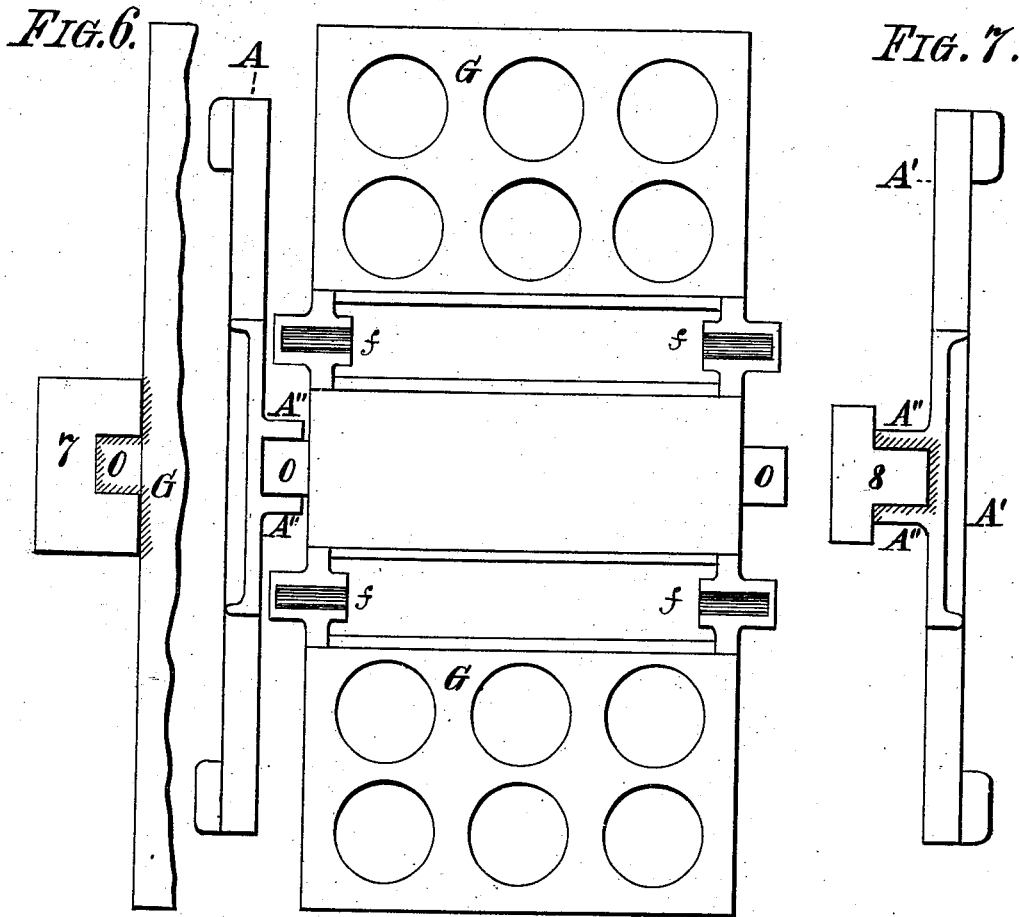

Witnesses:

Wm. J. Stark

Geo. Stark

Inventor:

Josiah Ross,
by Michael J. Stark atty

UNITED STATES PATENT OFFICE.

JOSIAH ROSS, OF BUFFALO, NEW YORK.

IMPROVEMENT IN PLANING-MACHINES.

Specification forming part of Letters Patent No. **210,149**, dated November 19, 1878; application filed September 19, 1878.

To all whom it may concern:

Be it known that I, JOSIAH ROSS, of Buffalo, in the county of Erie and State of New York, have invented certain new and useful Improvements on a Planing-Machine; and I do hereby declare that the following description of my said invention, taken in connection with the accompanying sheet of drawings, forms a full, clear, and exact specification, which will enable others skilled in the art to which it appertains to make and use the same.

This invention has special reference to planing-machines; and it consists in the novel arrangement of parts and details of construction, as hereinafter first fully set forth and described, and then pointed out in the claims.

In the drawings hereinbefore mentioned, which serve to illustrate my invention more fully, Figure 1 is a front elevation of my improved planing-machine. Figs. 2 and 3 are transverse sectional elevations in line *xx* of Fig. 1. Fig. 4 is a fragmental sectional elevation in line *yy* of Fig. 3. Fig. 5 is a plan. Fig. 6 is a fragmental plan of the table and a chill. Fig. 7 is a similar view of one of the standards and chill.

Like letters of reference indicate corresponding parts in all the figures.

A A' are the two sides or standards of a so-called "pony-planer," carrying the cylinder B in the usual manner, said cylinder revolving in bearings in the upper part of the said standards. C are the upper, and D the lower, feed-rollers, the former being pivoted within bearings E on the end of yokes F, and the latter revolving within half-boxes *f* in the table G. These bearings E are formed in one piece with a curved yoke, F, and their sides, which fit the bearing-notches in the standards A A', are curved, so as to allow the yoke to slightly oscillate or rock in said bearings without having any lateral play. The lower ends of the yokes F have notches, the edge of which is quite sharp at H to form a scale-beam bearing for the levers J, which are pivoted to the standards A A' at I. These levers J are weighted by means of counterpoises K, and they serve the purpose of furnishing a self-adjusting pressure device for the feed-rollers C.

One of the yokes F is pivoted centrally with a stud, L, Fig. 4, upon which revolves

the usual pulley 4, with its pinion 5, by means of which and the spur-wheels N said rollers C are revolved.

The table G has on both of its longitudinal sides laterally and downwardly projecting bars O, the lower ends of which are formed into toothed gear-racks O', engaging the pinions P upon a shaft, Q, passing transversely between and through the standards A A', and projecting with one end sufficiently out of said standard to receive a worm-wheel, R, engaging a screw-worm, S, fixed to an obliquely-arranged spindle, T, having on its upper extremity a hand-wheel, U, by means of which said spindle, and through it the worm S, worm-wheel R, shaft Q, and pinions P, is revolved. This hand-wheel U, when revolved in the proper direction, causes the table G to rise or fall, as the case may be, in a manner readily understood.

The standards A A' have obliquely-arranged projections *a* on their upper end, serving as guides for the hood V, which consists of a nearly-semicircular casting, having on both its ends flat projections *b*, also obliquely arranged, so as to fit the guides *a*, the angularity of these parts being such as to bring the front curve of said hood in line with a circle having its center coinciding with that of the cylinder B. On the back of said hood, and near both ends thereof, are rearwardly-projecting arms X, which are arranged to rest with their lower edges upon the reduced part O' of the rollers C, (see Fig. 4,) and the lower edge of said hood is so arranged as to slightly project over a line drawn from the lowest point in the periphery of one to that of the opposite roller C.

Z is the pressure-plate, secured between the standards A A' by means of the set-screws Z'.

The standards A A' have vertical projections A'', within which slide the laterally and downwardly projecting bars O of the table G. These projecting bars, as well as the inner sides of the guides A'', are cast in a "chill"—that is to say, instead of placing a sand core into the places intended to form the grooves between said projections A'' or letting them make their own core, and, instead of having the sand-mold forming said projecting bars O, perfectly-shaped metallic blocks 7 and 8, re-

spectively, are placed into the sand molds, which cause the iron to chill on the surfaces in contact with said metallic blocks, and thereby not only to harden them, but also to cause them to assume such perfect and exact shapes (owing to the perfect forms of the metallic blocks heretofore mentioned) as to enable me to dispense with any manual labor for shaping, planing, filing, or fitting said parts together, which is quite an item in the manufacture of wood-working machinery.

It will be observed that the two upper rollers, C, are pivoted within the yokes F, and the latter weighted by the scale-beam levers J and counter-weights K.

This arrangement is a very decided improvement in wood-working machines, since it perfectly equalizes the pressure upon the feed-rollers C without interfering in any manner with their raising and lowering independently of each other to accommodate themselves to the varying thicknesses of the lumber to be planed.

The yoke F, with the stud L, has, furthermore, the advantage of keeping the pinion 4 always in proper mesh with the spur-wheels N, and thereby avoid undue friction or binding or looseness in the teeth of said gear-wheels.

It will further be observed that, owing to the oblique arrangement of the hood V, which is inclined toward the cylinder B and loosely inserted in the guides *a*, and resting upon the unplanned side of the lumber, the same is caused to slightly recline when the stuff passes underneath it, and thereby to wedge itself tightly between said guides *a*, requiring no further mechanism to hold it in proper place, and pressing with all the necessary force upon the lumber to act as a perfect chip-breaker. By means of its arms X it is elevated and lowered automatically, so as to follow any undulations in the rough boards, &c.; but its lower edge being slightly beyond the lowest points of said feed-rollers, it is, by the passing stuff, caused to rise just sufficiently to release the arms X from pressing upon said rollers, and thereby to avoid friction and abrasion.

The worm-wheel arrangement of the mechanism for elevating and lowering the table is likewise a very essential feature in my machine, not only because it is extremely cheap, but also because it holds the table G so securely in any desired position as to preclude the possibility of its moving, which, in tables having miter or bevel wheels operating screws, is always more or less the case, the constant slight jar or vibration of the machine being more than sufficient to cause the bevel-wheels to move, while such has no effect whatever upon the worm and worm-wheel connection, as hereto-

fore described. It brings, furthermore, the hand-wheel U in the most convenient position for setting the table, and so high up that the operator can closely examine his work and adjust the machine without leaving his place of observation.

W is the shipper-rod, which consists of an angular rod of iron passed through apertures in the standards, and having its operating-handle in close proximity to the hand-wheel U, so that the operator has full control of all the operating mechanism without leaving his place in front of the machine.

The table, projecting bars O, and rack-bars O' are cast entire, and therefore dispense with screwing the said bars to the table, amounting to quite a saving in the cost of putting up this machine.

Having thus fully described my invention, I claim as new, and desire to secure to me by Letters Patent of the United States, the following:

1. In planing, &c., machines, the combination, with the feed-rollers C, pivoted within the yokes F, of the levers J and weights K, said levers being fulcrumed at I, and caused to act upon the lower extremity of said yokes midway between the rollers C, as and for the purpose stated.

2. In a planing-machine, the standards A, having the bearings for and in combination with the obliquely-arranged shaft T, provided with the hand-wheel U and worm S, the worm-wheel R, secured to the shaft Q, together with the pinions P and the gear-toothed rack-bars O' on the table G, whereby said table is vertically raised and lowered without change of plane, as and for the object specified.

3. A planing-machine having a hood, V, provided with projecting sliding bars *b* and arms X, said projections *b* being constructed to engage with obliquely-arranged guides *a* on the standards A A' and the arms X to rest upon the rollers C, as specified, for the object stated.

4. The combination, with the standards A A', having the obliquely-arranged projecting guides *a*, of the hood and chip-breaker V, provided with the projecting slides *b* and arms X, the latter being arranged to rest upon the feed-rollers C, as and for the purpose stated.

In testimony that I claim the foregoing as my invention I have hereto set my hand and affixed my seal in the presence of two subscribing witnesses.

JOSIAH ROSS. [L. s.]

Attest:

MICHAEL J. STARK,
JNO. STARK.