

G. C. SMITH.
Register.

No. 210,159.

Patented Nov. 19, 1878.

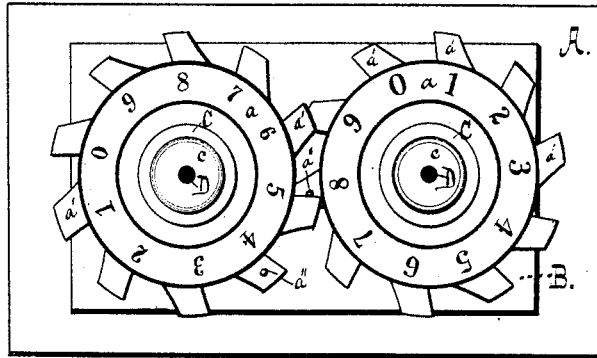

Fig. 1.

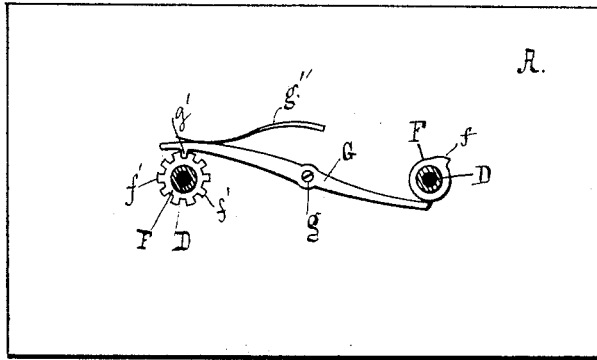
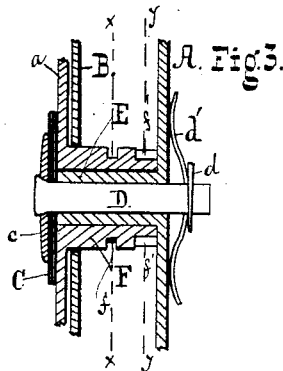

Fig. 2.



Witnesses,
David G. Weems
W. A. Beermann

Inventor
Geo. Smith.
by
R. W. Williams
Attorney.

UNITED STATES PATENT OFFICE.

GEORGE C. SMITH, OF BALTIMORE, MARYLAND.

IMPROVEMENT IN REGISTERS.

Specification forming part of Letters Patent No. **210,159**, dated November 19, 1878; application filed April 2, 1878.

To all whom it may concern:

Be it known that I, GEO. C. SMITH, of the city of Baltimore, State of Maryland, have invented certain new and useful Improvements in Registers; and I hereby declare the same to be fully, clearly, and exactly described as follows, reference being had to the accompanying drawings, in which—

Figure 1 is a plan view of the device; Fig. 2, a similar view, the dials and cover-plate being removed; and Fig. 3, a vertical sectional view through one of the dial-pivots.

While my present improvement is applicable to any registering device having revolving dials or arbors, it is especially adapted to the register described in Letters Patent granted to me March 12, 1878, No. 201,295.

In order that the present invention may be readily understood without necessarily referring to said Letters Patent, the construction of the register therein described will be here briefly set forth.

A large unit-wheel bearing numerals upon its face is actuated by means of a lever, ratchet, and pawl. The said wheel is furnished with a number of pins corresponding to the numerals upon its face, one of which pins, at each registration, actuates a gong-hammer. A single pin upon the opposite side of the unit-wheel engages at each complete revolution with a tens-wheel, and moves it through a single cog-space. Other wheels, representing hundreds, thousands, tens of thousands, &c., are similarly geared in a train, the entire mechanism being suitably mounted in a case adapted to be locked or sealed.

The present invention is designed to furnish means for preventing the fraudulent alteration of the indication of the register, even should the outer casing be removed. To this end each arbor is furnished with a locking mechanism out of the reach of any tool or implement, and which automatically releases the arbor at the instant of registration, and immediately thereafter again secures it.

In the accompanying drawings, A represents the main plate of the register, upon which the various wheels are mounted. But two dials are illustrated in the drawings, which, in fact, illustrate only so much of a register as is necessary to make my present in-

vention understood. The dials *a* are mounted upon arbors F, which turn upon tubular bearings E, attached to the plate A. Felt or leather washers C are held against the dial-faces by means of disks *e*, through which pass rivets D to the rear of the plate A. Springs *d'* being slipped over the ends of the rivets and secured by the pins *d*, the parts are held together with a yielding pressure.

In Fig. 2 is illustrated in detail the locking mechanism—the arbor on the right of the figure being represented in section on line *x x*, that on the left in section on line *y y*, of Fig. 3. The arbor of each dial or wheel in the train is provided with a cam, *f*, and a series of teeth, *f'*, the latter being equal in number to the numerals on its face—in this case ten.

Pivoted to the main plate A, between each pair of arbors, is a lever, G, having at one end a single lug, which enters successively the interstices between the teeth *f'*, and engaging at the other with a cam, *f*, as shown.

The operation of the mechanism is as follows: At each complete revolution of a dial, and just as its pin *a''* is about to engage with the cog *a'* of the next, the cam *f* upon the end of the arbor of the first dial depresses the end of the lever G, releasing the lug *g'* at the opposite end from engagement with the toothed arbor of the next wheel, which is then free to be, and is, rotated through a single cog-space. Immediately thereafter the lever is released, and its lug again falls into engagement with the toothed arbor, where it is retained by the spring *g''* until the next complete revolution of the first dial.

It will be observed that the cover-plate B is perforated for the admission of the various arbors, and the wheels fit snugly against it, rendering it impossible to insert any instrument between the arbor and plate.

The cover B is soldered to the main plate A, obviating the possibility of fraudulent undetected access to the registering mechanism, and as the same is effectually locked, the alteration of its indications, except by and in the manner of the legitimate and intended use of the device, is out of the question.

Having thus described my invention, what I claim as new, and desire to secure by Letters Patent, is—

1. In a registering device, the dials or indices thereof, having their arbors situated within a sealed case and normally locked, in combination with mechanism which automatically releases them at the moment when registration is being effected, the said dials being exterior to the sealed case, and constituting cover-plates for the arbor-orifices, substantially as set forth.

2. In a registering device, the dials or indices thereof, having their arbors situated within a sealed case, each dial actuating at each complete revolution the next dial in the train, and at the same time releasing a locking mechanism, the said dials being exterior to the sealed case, and constituting cover-plates for the arbor-orifices, substantially as described.

3. In combination with the main plate, having tubular shaft, the dials *a*, bolt D, and locking mechanism, substantially as described.

4. In combination with the arbors F F, having, respectively, a series of teeth and a cam, the lever G, having lug *g'* and spring *g''*, and the plate B, substantially as described.

5. In combination with the plate A, having shaft E, and wheel *a*, having arbor F, the plate B, substantially as described.

GEO. C. SMITH.

Witnesses:

S. D. WILLIAMS,
DAVID G. WEEMS.