

J. W. THOMAS.
Sash-Fastener.

Patented Nov. 19, 1878.

No. 210,167.

Fig. 1.

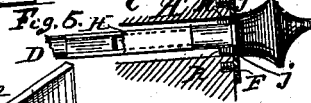
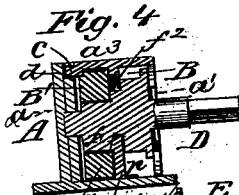
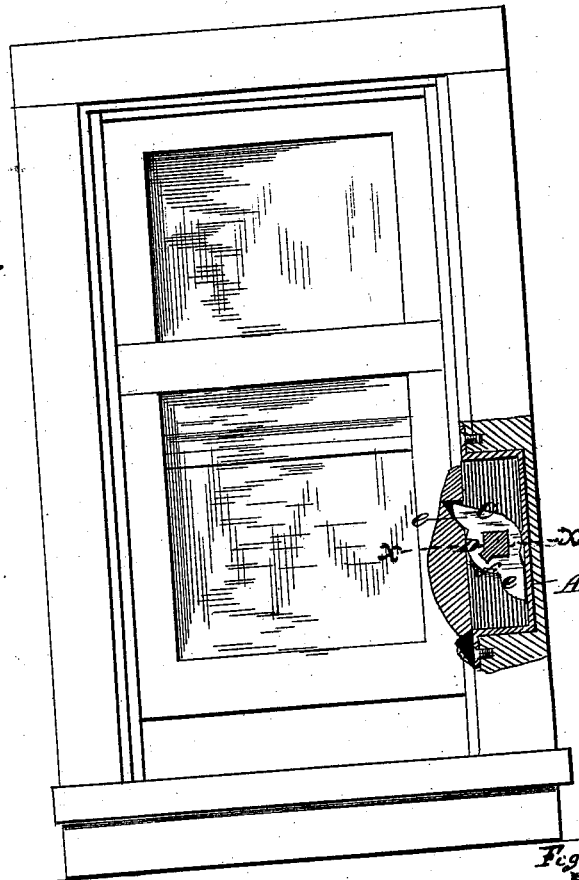

Fig. 2.

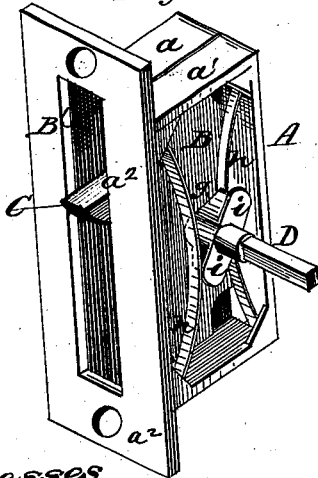
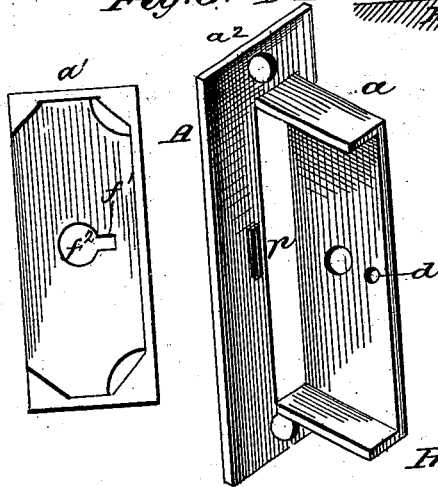

Fig. 3.



Inventor

Witnesses
Died L. Dütterich
Eduard A. Schmidt

John W. Thomas,
PER. C. A. Snow & Co.
attys.

UNITED STATES PATENT OFFICE.

JOHN W. THOMAS, OF TYRONE, PENNSYLVANIA.

IMPROVEMENT IN SASH-FASTENERS.

Specification forming part of Letters Patent No. **210,167**, dated November 19, 1878; application filed May 21, 1878.

To all whom it may concern:

Be it known that I, JOHN W. THOMAS, of Tyrone, in the county of Blair and State of Pennsylvania, have invented certain new and useful Improvements in Sash-Locks; and I do hereby declare that the following is a full, clear, and exact description thereof, which will enable others skilled in the art to which it appertains to make and use the same, reference being had to the accompanying drawings, which form a part of this specification, and in which—

Figure 1 is a side view of a window-casing with my improved fastener applied thereto, and shown in section. Fig. 2 is a view of the lock or fastener itself in perspective, and Fig. 3 is a perspective view of the two parts forming the lock-case, showing the said parts disconnected. Fig. 4 is a sectional view taken through the line *x x* in Fig. 1; and Fig. 5 is a sectional view, showing the key by which my improved sash-fastener is operated.

Corresponding parts in the several figures are denoted by like letters.

My invention relates to that class of sash locks or fasteners in which the lock is inserted in a mortise in the window-casing, its bolt being adapted to engage in notches or recesses formed in the side rail of the sash to lock it in position.

This invention has reference to certain improvements upon the Patent No. 192,529, and granted June 26, 1877, to Stephen Rush, the object of which is to render the working of the lock or fastener more effective, to promote the convenience of operation, and simplify the construction of the fastener; and it consists, primarily, in constructing or casting the lock or fastener case in two parts, and the manner of uniting the said parts together; and, secondarily, in certain other details of construction and arrangement of parts, substantially as hereinafter more fully set forth.

In the drawings, A refers to the lock-casing, which is cast or constructed in two parts, *a a'*. The part *a*, which is provided with the fastening-flange *a'*, is cast or constructed open at one side, and at its rear end, as shown in Fig. 3. The part *a'* is cast or constructed open at one side also, but with its rear end closed and extended laterally, as at *a''*, to close the opening in the rear end of the part *a* when the

parts are brought together. In order to lock the parts together, and to permit of their separation or detachability, the part *a* is provided with a slight elevation or stud, *p*, and the part *a'* with a lateral stud or projection, *c*, entering an aperture, *d*, in the part *a*.

The parts are put together by first inserting the lateral projection *c* into the aperture *d* of part *a*, and then forcing the inner end of the closed side of part *a'* over the slight elevation *p* of the part *a*, which will lock them together.

To separate the parts, pry one end of the part *a'*, and they will readily spring apart.

This method of constructing and uniting the parts of the case obviates the providing of the same with screw or rivet openings and the use of rivets or screws or similar fastenings heretofore employed for that purpose.

The case A is provided with a longitudinally and centrally dividing partition, A', formed with the part *a'*, to form the said case into two compartments, B and B', one of which contains the locking-lever and the other the locking-lever actuating springs and cams.

C is the sash supporting or locking-lever, having bent arms *e e*, one of which holds the lower sash in an elevated position, and the other, when the lever is turned in a reversed position, will secure it in a locked position when lowered. Of course this fastening is equally applicable to the upper sash for holding it in a lowered position or locking it securely when not lowered. The lever C is hung upon an operating-shaft, D, bearing in the casing A, the shaft being feathered, as at *f*, which feather enters a slot in the lever to cause the latter to turn with said shaft.

The part *a'* of the case A is also provided with a slot, *f'*, communicating with the aperture *f''* therein, which receives the end of shaft D. This slot is arranged so as to be out of line with the feather *f* on the said shaft after the latter is in position in the case. By this arrangement the shaft D is secured in its bearings without fastenings, such as are now commonly used. Upon the opposite side of the partition A' the lever-shaft D is provided with cams *g g*, against which is exerted the pressure of the springs *h h*, arranged in the compartment B' of the case A, and having their ends held in place by the corner-pieces *h' h'*

cast or otherwise affixed to the case. To prevent the lateral displacement of the springs, the shaft or spindle D is provided with arms *i i*, constructed with or otherwise applied to the said lever.

By thus duplicating the cams and springs, the operation or working of the fastener or lock is rendered more effective. It will not be overlooked that notches are provided in the side rails or rails of the sash, which may be lined or plated, as shown, to receive the arms of the lever, or rather their points.

The extending portion of the shaft or spindle D is square, which permits the application of a correspondingly-shaped sleeve, H, which receives the square shaft of a key, E, to effect the operation of the lever C. By this connection between the lever spindle or shaft D and its operating-key, the said spindle may be made of a uniform length for all sizes of windows, as either the tube H or key-shaft may be adapted to that end. Placed over the aperture through which the shaft or spindle D is reached is an escutcheon, F, with two opposite slots, *j j*, to admit of the passage through it of the feathers or nibs *k k* upon the key E.

It will be observed that by lengthening either one of the feathers *k k* of the key-shaft or either one of the slots *j* in the escutcheon F, and inserting the said key-shaft through the escutcheon, and turning the said key so as to bring the different-sized feathers and slots in a line with each other, and then inserting the key-shaft in the barrel of the spindle D and securing the escutcheon in position, the key will be connected to the above-mentioned

parts, so as to prevent its detachability, and thus be always in readiness for operating the lever C.

From the foregoing it will be observed that convenience in operating the fastener is promoted, simplicity of construction is obtained, and the working of the lock or fastener possessed of greater efficiency.

Having thus described my invention, I claim and desire to secure by Letters Patent of the United States—

1. In a sash lock or fastener, the case A, constructed in two parts, substantially as shown and described, one part, *a*, having an aperture, *d*, and a slight elevation, *p*, and the part *a'* provided with a lateral projection or stud, *c*, substantially as and for the purpose set forth.

2. The combination, with the case A, having the shaft or spindle D, provided with the lever C and cams *g g*, of the springs *h h* and the key E, adapted to fit the spindle D and operate it and the lever C, substantially as and for the purpose set forth.

3. The combination, with the partition, of the two-part case A *a a'*, said partition being provided with a slotted aperture, *f'*, of the lever C and its feather-shaft D, substantially as and for the purpose set forth.

In testimony that I claim the foregoing as my own I have hereto affixed my signature in presence of two witnesses.

JOHN W. THOMAS.

Witnesses:

JAS. J. PLUMMER,
W. L. PASCOE.