

G. H. CORMACK.  
Oatmeal-Machine.

No. 210,188.

Patented Nov. 26, 1878.

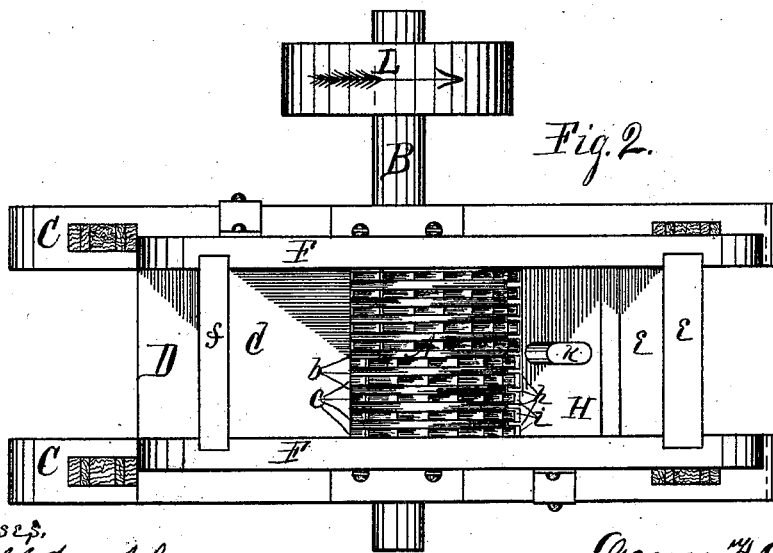
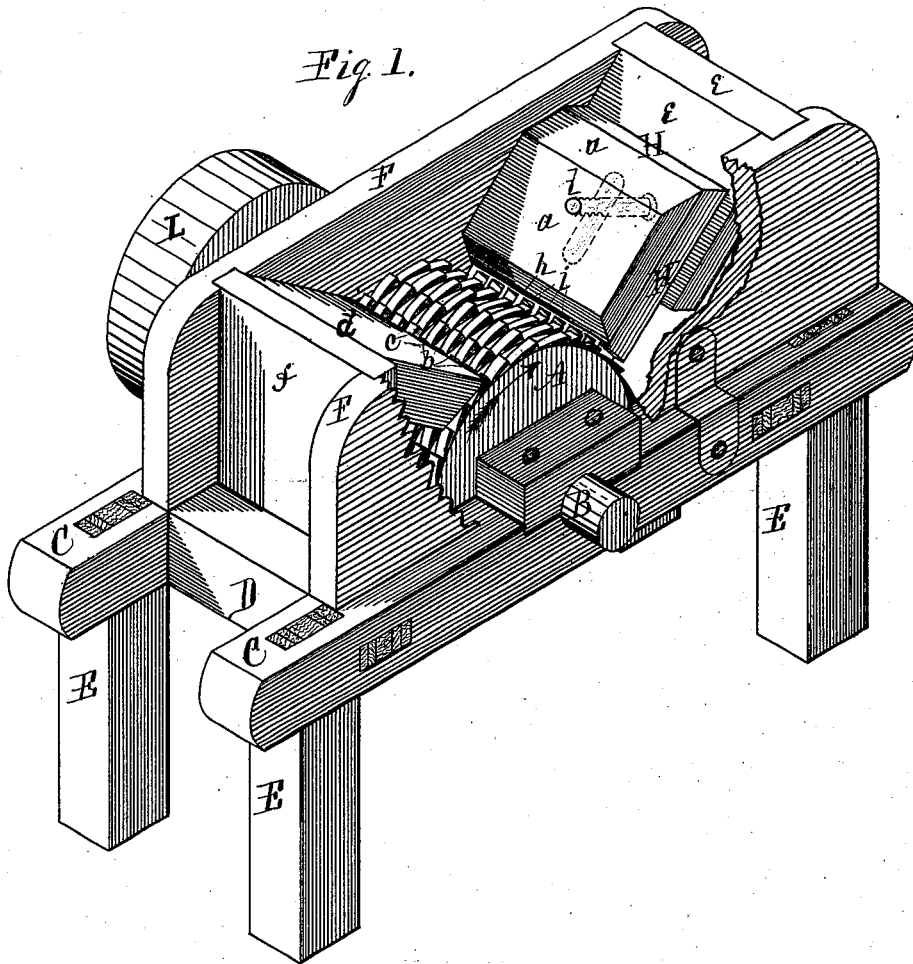

Witnesses,  
J. M. Doubler  
A. O. Behel

Inventor,  
George H. Cormack.  
Per. Jacob Behel  
Atty.

# UNITED STATES PATENT OFFICE.

GEORGE H. CORMACK, OF ROCKFORD, ILLINOIS, ASSIGNOR TO A. M. JOHNSTON & CO., OF SAME PLACE.

## IMPROVEMENT IN OATMEAL-MACHINES.

Specification forming part of Letters Patent No. 210,188, dated November 26, 1878; application filed March 26, 1878.

*To all whom it may concern:*

Be it known that I, GEORGE H. CORMACK, of the city of Rockford, in the county of Winnebago and State of Illinois, have invented a new and useful Improvement in Oat-Milling Machines, of which the following is a specification:

This invention relates to that class of machines employed in the manufacture of oatmeal or grits, and is employed, after the chaffy hull or shuck has been removed, to cut the grain into small sections or grits, forming a clean sharp oatmeal with but little waste.

To this end I have devised and constructed the machine represented in the accompanying drawings, in which—

Figure 1 is an isometrical representation of my improved oatmeal-cutting machine, in which portions of the frame are broken away to more clearly show the machine. Fig. 2 is a plan view of the same, in which the beveled cap *a* on the upper side of the notched or toothed cutting-plate is omitted to more clearly show the notched or toothed plate.

In the drawings, A represents an oat-cutting cylinder, formed of disks provided on their periphery with alternate annular grooves *b* and annular fillets *c* in about equal divisions. The annular fillets *c*, which rise above the annular grooves *b*, are at proper intervals formed in teeth similar to the teeth of a circular slitting-saw. A series of these disks with annular grooves and annular fillets, toothed as above, are mounted on a shaft, B, to which they are fixed to revolve with the shaft. A sufficient number of these disks are placed on the shaft in close contact to form a cutting-cylinder of any practical length. The shaft of this cylinder is fitted to revolve in bearings on the horizontal beams C of the main frame, with the grooved and toothed cylinder to revolve between the beams.

The beams C form the sides of the main supporting-frame, and are connected by end beams, D, framed into their inner faces toward their ends. This horizontal frame is supported on posts E, framed into the under faces of the side beams, C. These parts—viz., the side beams, C, end beams, D, and posts E—form the main frame, in which the cutting-cylinder is mounted to revolve on its journal-bearings.

F are sides of an upper box-frame with inward-beveling ends *d* and *e* and a vertical end *f*, which are secured firmly to each other, and form the upper casing and a portion of the hopper to the cutting-cylinder. This box-frame is placed over the cutting-cylinder in the main frame in such position that the under beveled edge of the inclined end *d* shall about touch the cutting-cylinder, and in this position is secured to the main frame firmly.

H is a metallic plate having one or both of its edges notched in comb form, having teeth *h* to correspond, and fitted to enter the annular grooves *b* in the cutting-cylinder, and notches *i*, which receive the teeth formed in the annular fillets *c* on the cutting-cylinder. This toothed plate is provided with a transverse slot, *k*, and the plate is placed on the inclined end *e* in such position that its teeth *h* enter the grooves *b*, and the notches *i* receive the teeth on the fillets *c* in such a manner as to permit the cylinder to revolve freely. The teeth *h* of the plate H and the grooves *b* in the cutting-cylinder A, the teeth *c* in the cylinder A and the notches *i* in the plate H, are made to fit as close as practicable, to permit of the cylinder revolving freely without cutting the teeth in the plate. *a* is a cap-plate having beveled edges, and is placed on the upper side of the toothed plate H, with one of its beveled edges toward the toothed cylinder, and at such a distance from it as to permit the oat-grains to freely pass from the hopper to the toothed plate, and to prevent them being thrown therefrom when acted upon by the teeth of the cylinder. This bevel-edged plate *a* and the toothed plate H are held in an adjustable manner in position on the beveling end *e* by means of a screw, *l*, which is passed upward through the beveled end *e*, toothed plate H, and screw-threaded into the bevel-edged cap-plate *a*.

L represents a pulley mounted on the outward-projecting end of the cylinder-shaft, and is for the purpose of imparting motion to the cylinder by means of a belt connecting the pulley with a driving-pulley connected with the motor.

In the manufacture of oatmeal with my improved oat-cutting machine, with the machine set in motion in the direction indicated by the

arrows, the shelled oats are passed into the hopper onto the toothed cylinder in any convenient manner, and the rotation of the cylinder in connection with gravity will carry the oat-grains onto the teeth of the plate H, where they will be cut into meal or grits by the shear action of the teeth of the cylinder passing between the fixed teeth of the toothed plate H, and carried through with the revolving cylinder, and permitted to drop into any receptacle provided for its reception. In this method of cutting oats in the manufacture of meal, the tendency would be to throw the grain from the cutters, and the grain would be liable to approach the cutters endwise, all of which would tend to retard the operation and lessen the quantity of sharp grits and increase the quantity of dust or fine meal from a given quantity of grain. To obviate the above tendencies, I have introduced the bevel-edged plate *a* to narrow the throat and prevent the throwing back of the grain.

In the foregoing I have described my improved cutting-cylinder made of disks of considerable thickness, constructed with alternate grooves and toothed fillets mounted on a suitable shaft in close contact, and this method I

prefer, and I also prefer to make these disks of a good quality of iron, and case-hardened; but they may be made of any suitable material; and, instead of the grooved disks, the cylinder may be made of one piece, or of thin or plate disks alternately large and small. The large disks being toothed, as hereinbefore described, and the smaller disks being placed between the larger toothed disks, form the grooves.

I claim as my invention—

1. The combination, with a cylinder provided with a series of teeth, separated by annular grooves, of a hopper-plate provided with a notched edge, which fits closely the teeth and grooves on the cylinder, substantially as set forth.

2. The combination, with a toothed cutting-cylinder and a toothed cutting-plate, of the bevel-edged plate, operating to prevent the grain from being thrown from the cylinder, substantially as set forth.

GEORGE H. CORMACK.

Witnesses:

A. O. BEHEL,  
DUNCAN FERGUSON.