

U. CUMMINGS.
Rock-Drill.

No. 210,189.

Patented Nov. 26, 1878.

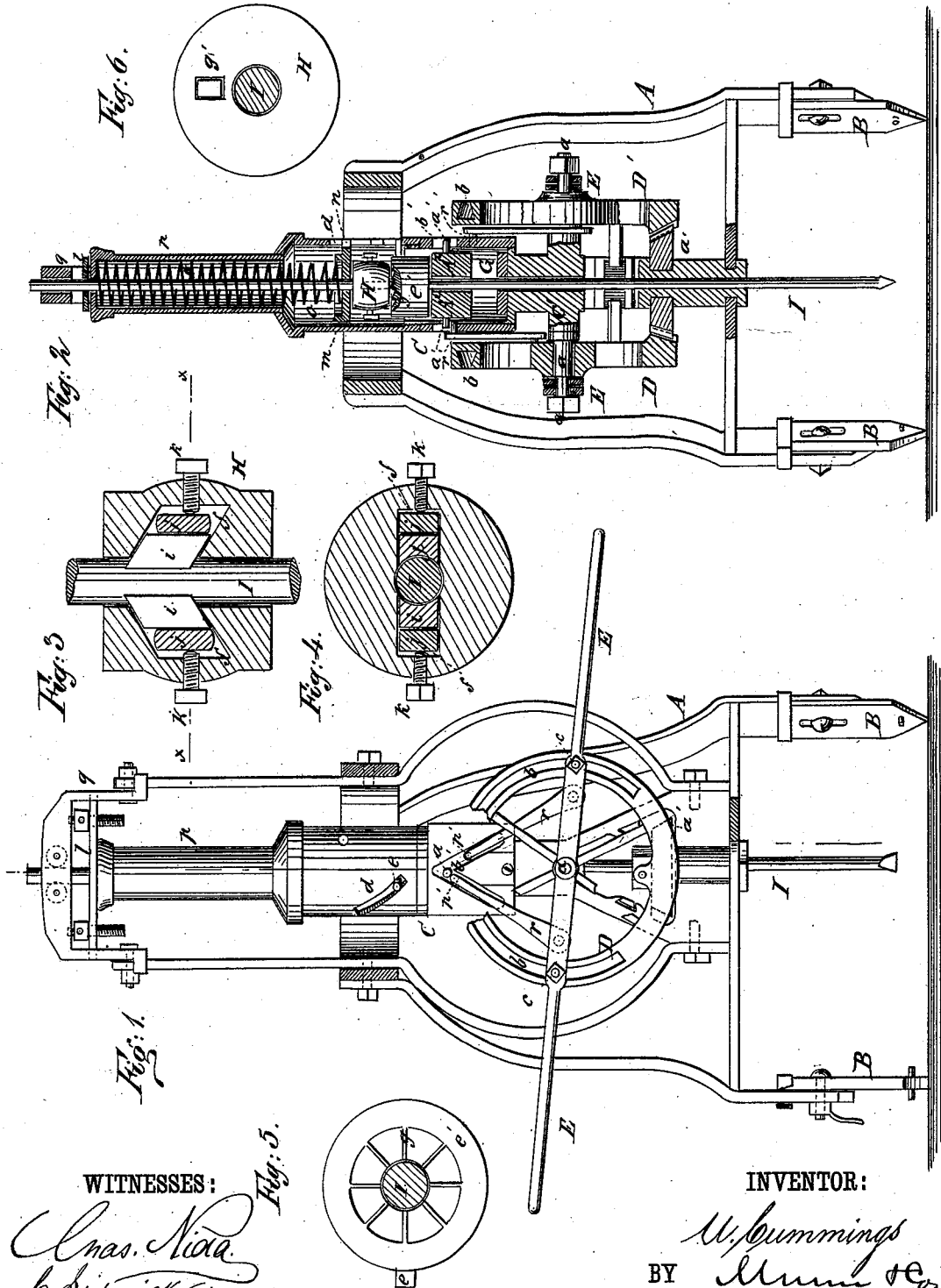

WITNESSES:
Chas. Nida
C. Bidgwick

INVENTOR:
U. Cummings
BY *Mum & Co*
ATTORNEYS.

UNITED STATES PATENT OFFICE.

URIAH CUMMINGS, OF BUFFALO, NEW YORK, ASSIGNOR TO HIMSELF AND ARTHUR W. WHITE, OF SAME PLACE.

IMPROVEMENT IN ROCK-DRILLS.

Specification forming part of Letters Patent No. 210,189, dated November 26, 1878; application filed April 22, 1878.

To all whom it may concern:

Be it known that I, URIAH CUMMINGS, of Buffalo, in the county of Erie and State of New York, have invented a new and Improved Rock-Drill, of which the following is a specification:

Figure 1 is a front elevation, partly in section. Fig. 2 is a vertical section. Fig. 3 is a detail sectional view of the clutch-head. Fig. 4 is a horizontal section, taken on line *x x* in Fig. 3. Fig. 5 is a detail view of the ratchet. Fig. 6 is a detail view of the lower face of the clutch-head.

Similar letters of reference indicate corresponding parts.

The object of my invention is to provide a rock-drill that may be operated effectively and continuously by hand-power without unduly tiring the operator.

The invention consists in a drill propelled by a spring that is compressed by two hand-levers geared together, so as to move in opposite directions, and carrying pawls which alternately lift the drill.

It also consists in a clutching and rotating device of novel construction which causes the drill to operate with regularity.

Referring to the drawing, A is a tripod-frame, having extension-pieces B, which support the frame at any desired height. In the frame A a barrel, C, is supported, and upon each side of a casting, C', attached to the lower portion of the barrel, wheels D D' are journaled on studs *a*, that project in the same axial line from opposite sides of the casting C'. Dovetail slots *b* are formed in the rims of these wheels for receiving the bolts *c*, by which the lever-arms E are secured to the said wheels. The wheels and lever-arms are alike on both sides of the barrel, and each pair of arms E form, with the wheel D or D', an equal-armed lever, whose fulcrum is on the stud *a*. The wheels have, on their inner face, a segment of bevel-gear which engages a bevel-pinion, *a'*, placed on a sleeve at the lower end of the casting C'. By means of this arrangement the levers are made to move in opposite directions. Spiral slots *d* are formed in opposite sides of the barrel C to receive studs *e*, projecting from the ratchet *e'*, contained by the barrel. These

slots are equivalent to the length of the stroke of the drill. The ratchet *e'* is loosely fitted to the barrel, and is bored axially to receive the drill-rod I, which also passes axially through the barrel C. The ratchet-teeth *g* are formed on the upper face of the ratchet, and from diametrically-opposite sides of the ratchet *e'* studs *e* project through the spiral slots *d* in the barrel C. Below the ratchet *e* there is a short sleeve, A², through which the drill-rod I passes, and from diametrically-opposite sides of which studs *a'* project through inverted V-shaped slots *b'*, formed in opposite sides of the barrel C. At the lower end of the barrel C there is a buffer-spring, G, of rubber or other suitable material, for arresting the downward movement of the short sleeve A². Above the ratchet *e'* there is a clutch-head, H, which is bored to receive the drill-rod I, and is provided with two cavities, *f*, on opposite sides of the drill-rod, for containing the clamping-pieces *i*, which are pressed into contact with the drill-rod by the rubber springs *j*. The rubber springs abut upon set-screws *k*, by which the pressure of the spring may be adjusted. The upper and lower walls of the cavities *f* are inclined downward and outward. Between the cavities *f* on each side of the cylinder-head there is a mortise containing a pawl or bolt, *g'*, which is forced into engagement with the ratchet *e'* by a rubber spring.

A plate, *m*, having a lug, *n*, that projects through the slots *d*, is placed upon the clutch-head H to receive a spiral spring, *o*, that is incased by the tube *p*, that rests against an adjustable bar, *l*, whose ends slide in slots in the upper portion, *q*, of the frame A, and is capable of sliding through the cap of the barrel C. The bar *l* is capable of being moved up or down to adjust the pressure of the spring *o* on the clutch-head H by means of adjusting-screws *v*, that bear against the upper part of the frame A.

To diametrically-opposite sides of the wheel D pawls *r* are pivoted. These pawls are provided with pins *r'*, which move in the V-shaped groove. The pins *r'*, carried by the free ends of the pawls, engage the studs *a* when the levers D D' are oscillated.

A small force-pump may be attached to the

lower end of the barrel for forcing water into the drill-hole to facilitate the operation of drilling. The drill-rod I passes between guide-rollers at the top of the machine, and is threaded at its upper end, so as to receive additional sections of drill-rod when required.

The hand-levers are moved in opposite directions by the operators, two in number, who stand between the ends of the levers and grasp one in each hand. By oscillating the levers the pawls r' are alternately raised and lowered. As the pawls rise they engage the studs a , projecting from the ratchet e' , and thus raise the sleeve, the clutch-head, and the drill-rod I until the stud, by following the inclined slot in the barrel, arrives at the apex of the angle of the inverted V-shaped slot, when it slips from the pin in the end of the pawl and follows the opposite limb of the V slot. As the ratchet is raised it turns the clutch-head, and consequently the drill, while the plate m , at the top of the clutch-head H, is prevented from turning by the engagement of the lug n with the slot d in the barrel. When the stud a slips from the rim r' of the pawl r , the spring o forces the clutch-head and drill downward.

The pressure of the spring may be varied by adjusting the bar l in the upper portion of the frame, as previously described. The stroke of the drill is about four inches, and the stroke of the outer end of the operating-levers is about fourteen inches. With this slight movement of the levers, the drill is easily raised

against the spring-pressure. As the pivot of the pawl gradually nears the fulcrum of the operating-levers it virtually shortens the shorter end of the operating-lever, forming at the same time a toggle-joint, by which the spring is compressed with the expenditure of a small amount of power.

Having thus fully described my invention, I claim as new and desire to secure by Letters Patent—

1. The combination, in a rock-drill, of two adjustable oscillating levers, arranged to move simultaneously in opposite directions, substantially as herein shown and described.

2. The combination, in a rock-drill, of the pawls r , the oscillating lever, having arms E, the sleeve A^2 , having studs a' , and a clutching device, as herein shown and described.

3. The barrel C, having the angled slots b' , the pawls r , having pins r' , and the sleeve A^1 , in combination, as herein shown and described.

4. The sleeve A^2 , having studs a' and the ratchet e' , and barrel C, having a spiral slot, d , in combination, substantially as herein shown and described.

5. The combination of the adjustable tube p with the barrel C for containing the drill-actuating spring o , substantially as herein shown and described.

URIAH CUMMINGS.

Witnesses:

BENJ. A. PROVOST,
M. F. WARREN.