

H. WATKEYS.
 Valve-Seat for Steam-Cylinders.

No. 210,279.

Patented Nov. 26, 1878.

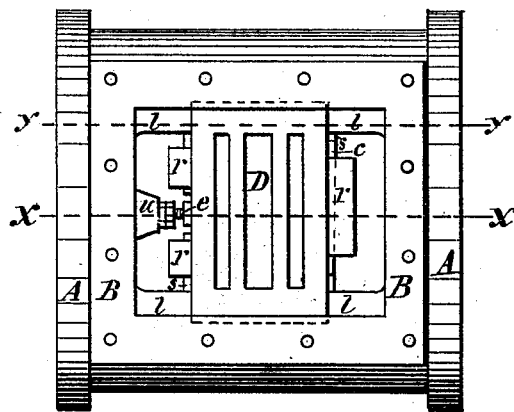

Fig. 2

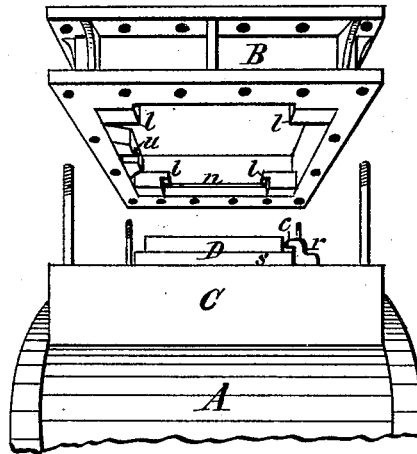

Fig. 1

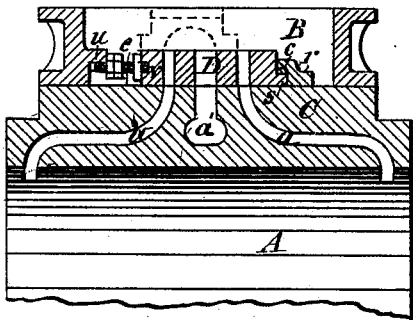

Fig. 3

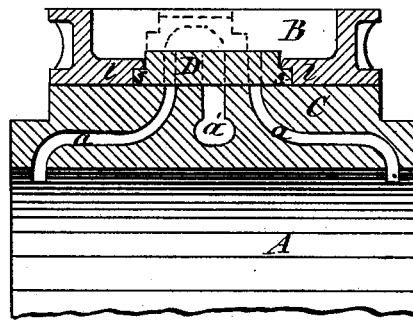

Fig. 4

WITNESSES:

A. Bell

C. Bendixen.

INVENTOR:

Henry Watkeys
 per E. Laass his Atty.

UNITED STATES PATENT OFFICE.

HENRY WATKEYS, OF SYRACUSE, NEW YORK.

IMPROVEMENT IN VALVE-SEATS FOR STEAM-CYLINDERS.

Specification forming part of Letters Patent No. **210,279**, dated November 23, 1878; application filed September 13, 1878.

To all whom it may concern:

Be it known that I, HENRY WATKEYS, of the city of Syracuse, in the county of Onondaga, in the State of New York, have invented new and useful Improvements in Valve-Seats for Steam-Cylinders, of which the following, taken in connection with the accompanying drawings, is a full, clear, and exact description.

This invention relates more particularly to the cylinder face or seat of reciprocating or so-called "slide" valves of steam-engines; the object of the invention being to provide the cylinder with a face or valve-seat which shall be more readily attached and detached, and thus capable of being redressed or refaced with great facility and at a materially-reduced expense, and, when worn out, readily substituted by a new one, and, furthermore, shall be adjustable in its position.

The invention consists, essentially, of a plate or diaphragm provided with the requisite steam and exhaust ports, and detachably confined upon the cylinder-face by shoulders on the interior of the steam-chest and by set-screws or wedges connected therewith, all as hereinafter fully described.

In the accompanying drawings, Figure 1 is a perspective side view of a steam-chest, detached from the cylinder to show my improvements; Fig. 2, a top view of a steam chest and cylinder provided with my improvements; Fig. 3, a longitudinal section on line *xx* in Fig. 2, and Fig. 4 a longitudinal section on line *yy* in Fig. 2.

Similar letters of reference indicate corresponding parts.

A represents the steam-cylinder, and B the steam-chest, of a reciprocating engine. The top portion of the cylinder is usually cast with a saddle, C, of sufficient height to contain internally the exhaust-port *a'* and steam-channels *a a*, by which latter the cylinder communicates with the steam-chest, mounted on top of the saddle C. The top surface of this saddle is usually cast with a raised face or valve-seat, which is planed to form a uniform true bearing for the valve, which slides thereon. The friction resultant from the movement of the valve necessitates frequent redressing or refacing of the valve-seat, and this operation has, on account of the inconvenience of ac-

cess to the valve-seat, generally been accomplished by chipping and filing, and was therefore rendered expensive, not only in the time and labor required, but also in the amount of files consumed in the operation.

It is to obviate these difficulties, and to a great extent their attending expenses, which my invention has for its object, and to attain this I interpose between the cylinder-face and valve a detachable valve-seat, D, in the form of a plate or diaphragm, provided with the requisite steam and exhaust ports, and secure it in its position by shoulders or lugs, either on the cylinder or sides and ends of the steam-chest, and by set-screws or wedges, or the equivalent devices, arranged to tighten it.

When my invention is to be applied to the old form of steam-chests, I bolt to the cylinder-face, at opposite ends of the detachable valve-seat D, flanged lugs or ribs *r r*, which engage with a flange, *s*, on the base of the said valve-seat. In this case the valve-seat is inserted endwise, and tightened by a wedge or key, *c*, driven between the engaging parts. With new cylinders the ribs *r* can be cast on the cylinder-face. In case the proximity of the steam-inlet port to the steam-chest does not admit of the rib *r*, I cast on the inside corners of the steam-chest lugs *l*, abutting against the ends of the valve-seat, D, and having a flange engaging the top of flange *s* on same. To compensate for any variations which may occur in the size of the interchanged valve-seat, and to properly tighten and adjust the same in its position relative to its ports with those in the cylinder-face, I arrange between one end of the valve-seat and the adjacent end of the steam-chest a set-screw, *e*, by means of which and, if necessary, a wedge at the opposite end of the valve-seat, the latter can be set so as to bring its ports properly over those in the cylinder-face. To prevent the set-screw, in case of its working loose, becoming displaced and interfering with the working of the valve or causing other injury, I fit the ends of the set-screws in sockets *u* and *v*, respectively, in the steam-chest and valve-seat of sufficient depth to retain the set-screw. This set-screw may be employed in connection with either the lugs *l* or ribs *r*, as fully shown in Fig. 2 of the drawing.

In order to brace the central portion of the valve-seat D, I provide the sides of the steam-chest with a shoulder, *n*, which rests on the flange *s*, extended around the sides of the valve-seat; and in case the steam-chest is too short to admit of either the lugs *l* or ribs *r*, before described, I employ the said shoulder *n* as the principal means of resisting the back-pressure upon the valve incident to the reversing of the engine, and secure it against other displacement by extensions of its ends near the sides thereof, and abutting against opposite ends of the steam-chest. The function of the overlapping part of all the described lugs and shoulders bearing down upon the valve-seat D, is merely to prevent its lifting off the cylinder-face under the circumstance last mentioned, experience having proved that the pressure acting on the valve and valve-seat when the engine is in operation is sufficient to hold the valve-seat steam-tight upon the cylinder-face.

It will be observed that either of the described constructions admit of a ready attachment and detachment of the valve-seat, which feature is the essential part of my invention, as by that means I am enabled to remove the worn or injured valve-seat from the cylinder and place it in a planer to reface it; and by

keeping on hand duplicates of the valve-seat, the injured valve-seat can immediately be substituted by a perfect one, and thus frequently save expensive delays or stoppages of the use of the engine.

Having thus described my invention, what I claim is—

1. The valve-seat D, having steam and exhaust ports and mounted loose on the cylinder-face, and provided with flange *s*, in combination with lugs or shoulders either on the cylinder-face or interior of the steam-chest, and having a flange engaging with that of the valve-seat, and a set-screw or key arranged to adjust and tighten it longitudinally in its position, substantially as described.

2. The combination of the valve-seat D, mounted loose on the cylinder-face, and provided with flange *s*, the rib *r*, attached to the cylinder-face, and the set-screw *e*, fitted in sockets *u* and *v*, respectively, in the end of the steam-chest and end of valve-seat, substantially as specified and shown.

In testimony whereof I have hereunto set my hand this 9th day of September, 1878.

HENRY WATKEYS.

Witnesses:

C. BENDIXEN,

C. R. HOLMES, Jr.