

A. G. CLINE.
Water-Wheel.

No. 210,298.

Patented Nov. 26, 1878.

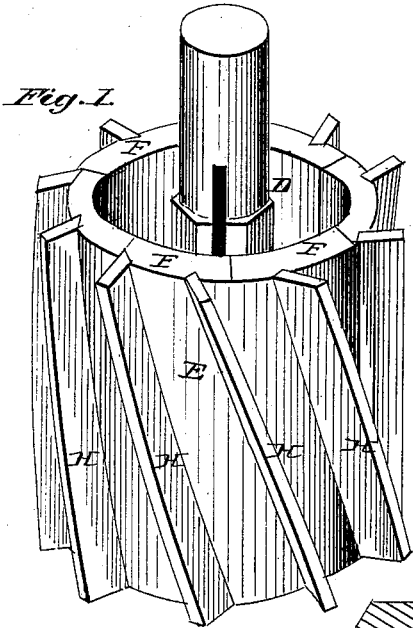

Fig. 2.

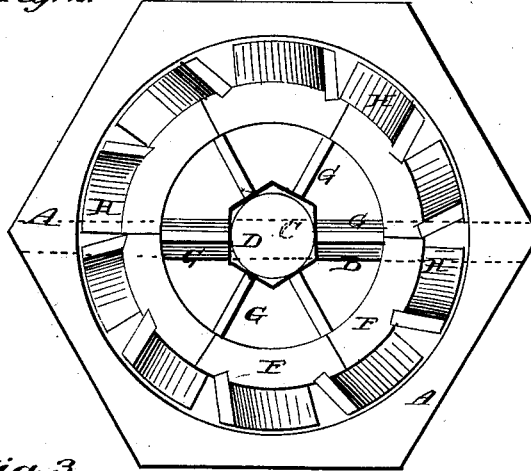

Fig. 3.

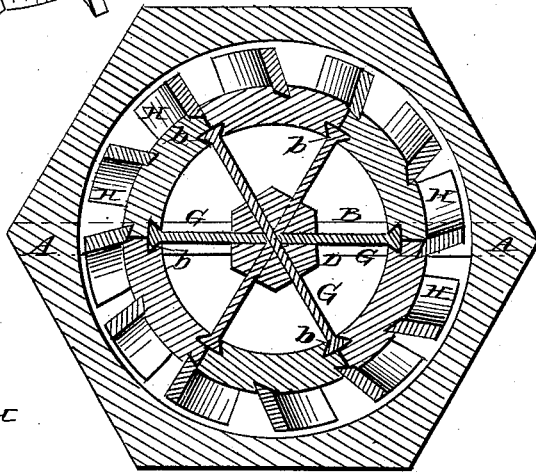

Fig. 4.

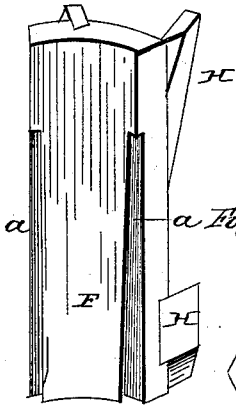

Fig. 5.

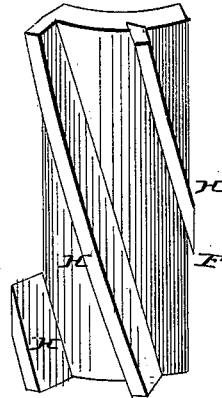
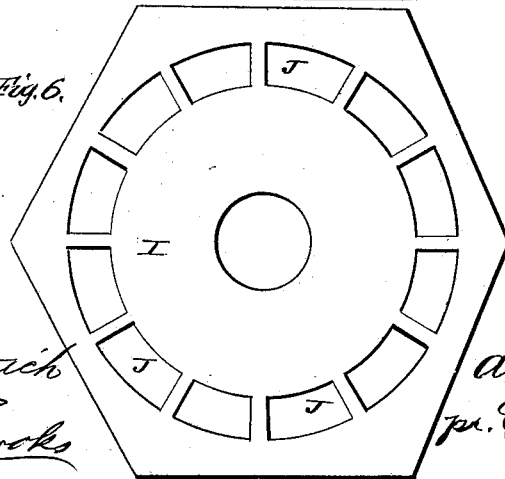

Fig. 6.



Witnesses

Fred G. Dietrich

Jno. P. Brooks

Inventor

Albert G. Cline,

per C. A. Snow & Co.
Attorneys

UNITED STATES PATENT OFFICE.

ALFRED G. CLINE, OF CRETE, NEBRASKA.

IMPROVEMENT IN WATER-WHEELS.

Specification forming part of Letters Patent No. **210,298**, dated November 26, 1878; application filed September 23, 1878.

To all whom it may concern:

Be it known that I, ALFRED G. CLINE, of Crete, in the county of Saline and State of Nebraska, have invented certain new and useful Improvements in Water-Wheels; and I do hereby declare that the following is a full, clear, and exact description of the invention, which will enable others skilled in the art to which it appertains to make and use the same, reference being had to the accompanying drawings, which form a part of this specification, and in which—

Figure 1 is a view, in perspective, of the drum of a water-wheel embodying the improvements in my invention. Fig. 2 is a plan view of the case and wheel. Fig. 3 is a horizontal cross-section of the case and wheel. Fig. 4 is an interior view of one of the removable sections of which the wheel is composed, showing the grooves by which the sections are connected to the flanged arms. Fig. 5 is an outside view of one of the sections removed. Fig. 6 is hereinafter referred to.

This invention has relation to water-wheels; and it consists of the improvements in the construction of the same hereinafter fully described, and particularly pointed out in the claims.

In the accompanying drawings similar letters of reference indicate corresponding parts in the several figures.

The outside of the case A, in this instance, is hexagonal in form, the interior being circular. A cross-piece, B, traverses the bottom of the case A, and is provided with a step, C, in which the lower end of the shaft D revolves.

The water-wheel F is constructed in removable sections F, having on their inner sides grooves *a a*, which receive flanges *b b* upon the outer ends of the arms G, secured to the shaft D in any suitable manner, as by mortising,

or otherwise. The sections F have diagonal ribs H, the faces of which are straight and the edges are curved, as shown; and these ribs H are so arranged that the top of one and the bottom of the next preceding one come in the same vertical plane. In order to make the sections F of the wheel or drum E removable the ribs H must be constructed in sections, as shown in Fig. 6.

A top, I, having slots or openings J, is secured to the top of the case A, and through these openings the water is admitted to the wheel.

When one of the sections F becomes damaged or broken it can be removed and a new one substituted, thus saving the expense and labor of putting in an entire wheel. The sections can be kept on hand for use, and as they are all of the same size they can be used to replace any one of the sections.

Having thus described my invention, what I claim as new and useful, and desire to secure by Letters Patent of the United States, is—

1. In a water-wheel, the drum E, composed of the removable sections F, constructed and operating substantially as set forth.

2. A water-wheel, E, composed of the sections F, having grooves *a a* and ribs H, in combination with the flanges *b b* on the outer ends of the arms G, secured to the shaft D, constructed and operating substantially as and for the purposes set forth.

In testimony that I claim the foregoing as my own I have hereto affixed my signature in presence of two witnesses.

ALFRED G. CLINE.

Witnesses:

WILL. W. WATSON,
J. D. ACKARET.