

J. B. FULLER.

Induction Apparatus for Lighting by Electricity.  
No. 210,317. Patented Nov. 26, 1878.

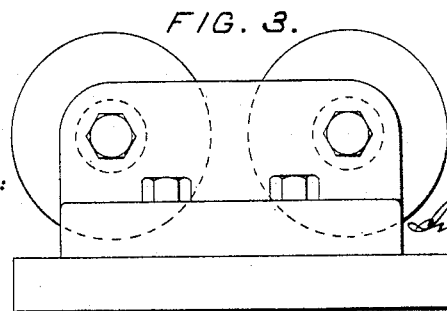
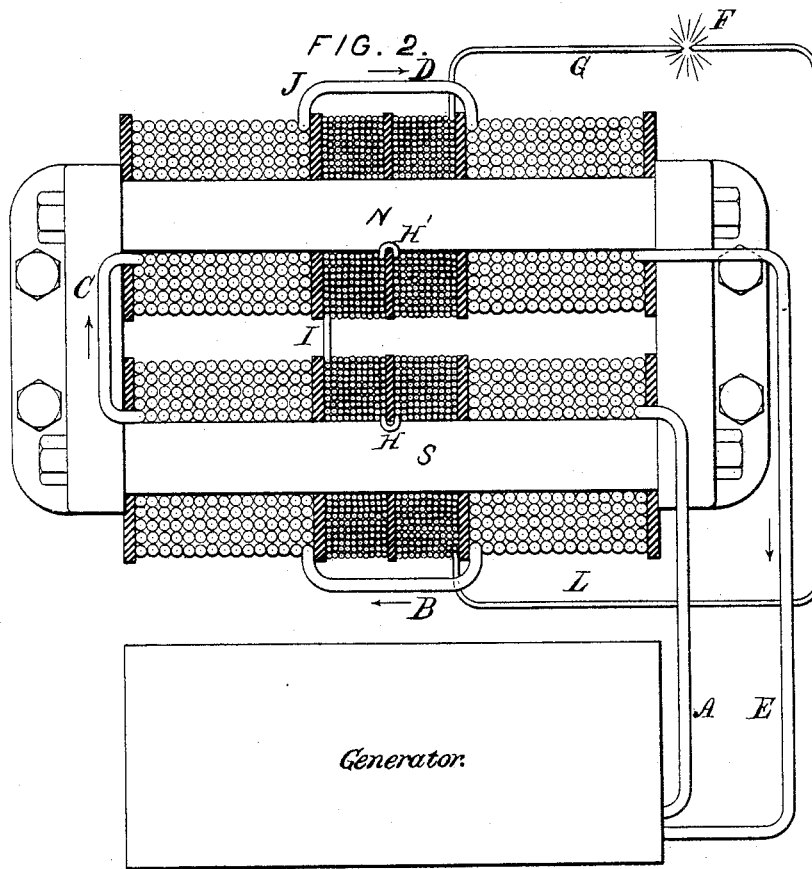
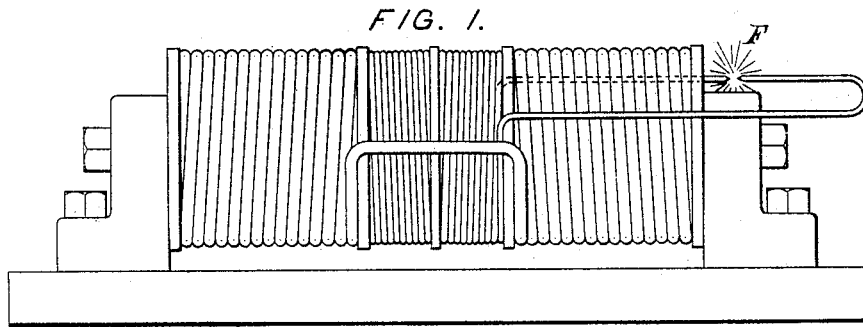

WITNESSES:  
*John W. ...*  
*J. N. ...*

INVENTOR:  
*J. B. Fuller.*

J. B. FULLER.

Induction Apparatus for Lighting by Electricity.  
No. 210,317. Patented Nov. 26, 1878.

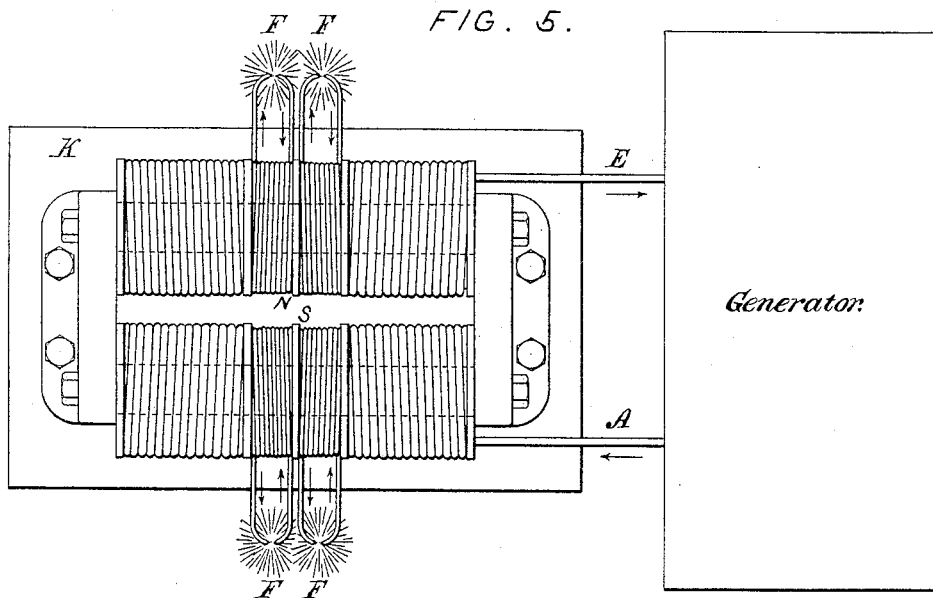
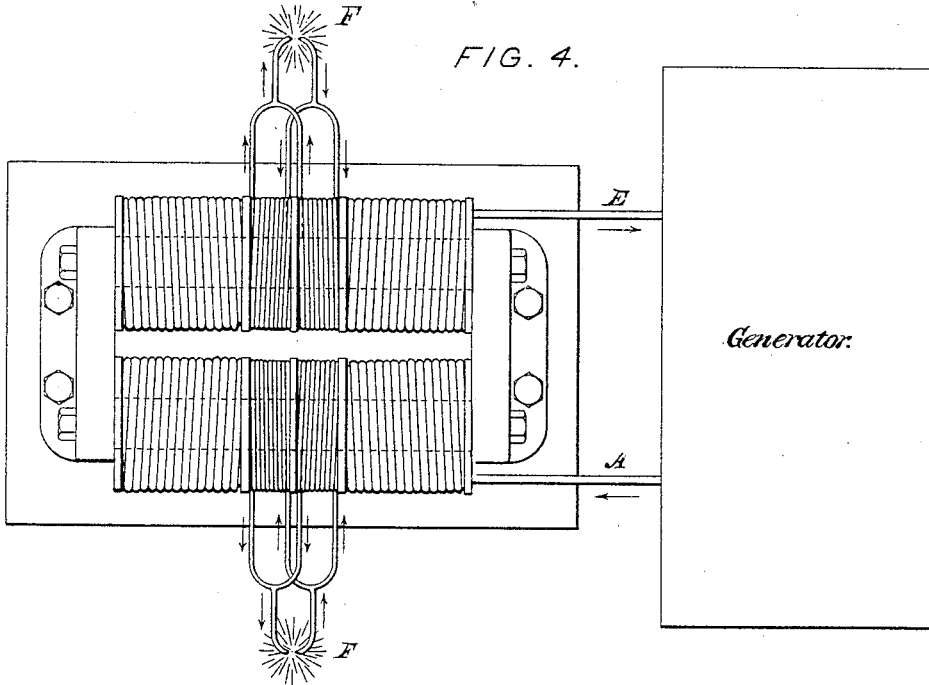

WITNESSES:  
*John Sumner*  
*J. N. Randall*

INVENTOR:  
*Jim Billing Fuller*

J. B. FULLER.  
Induction Apparatus for Lighting by Electricity.  
No. 210,317. Patented Nov. 26, 1878.

FIG. 6.

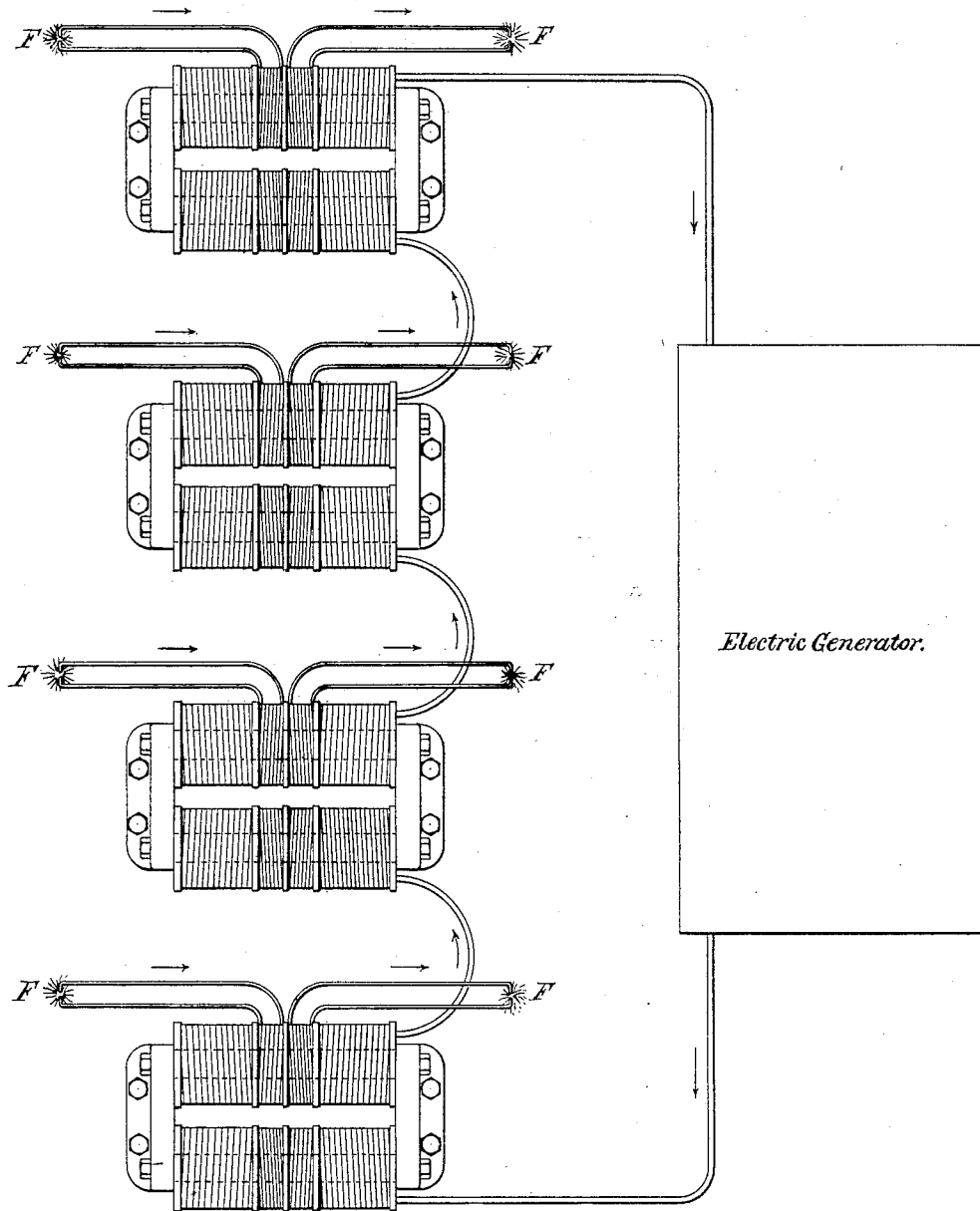

WITNESSES:

*Johannes*  
*J. W. Grandall*

INVENTOR:

*Jim Billing Fuller*

J. B. FULLER.  
Induction Apparatus for Lighting by Electricity.  
No. 210,317. Patented Nov. 26, 1878.

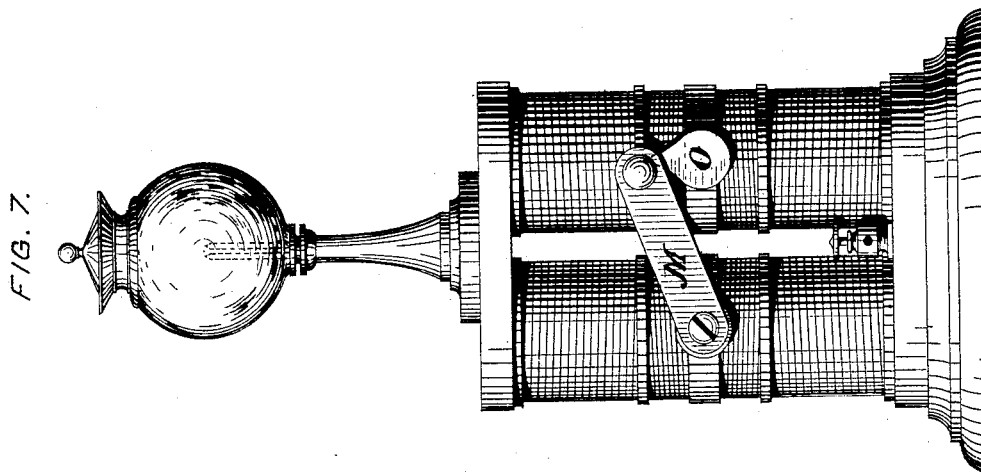
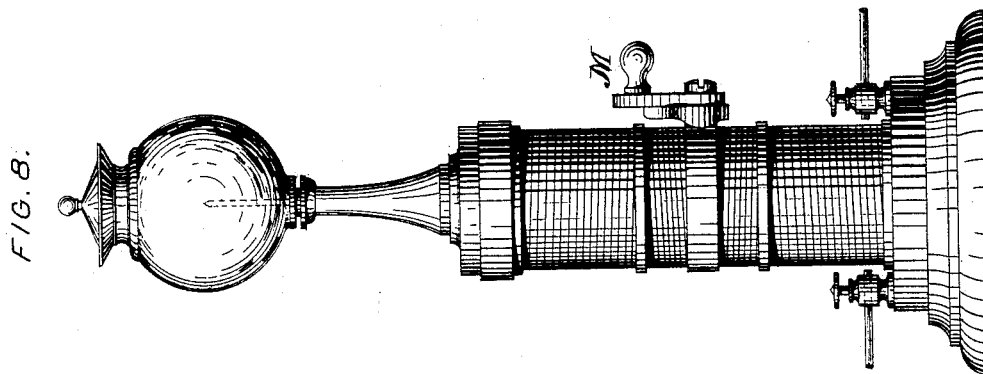

WITNESSES:

*John Cummins*  
*J. V. Crandall*

INVENTOR:

*Jim. Billing, Fuller*

# UNITED STATES PATENT OFFICE

JIM B. FULLER, OF BROOKLYN, NEW YORK.

IMPROVEMENT IN INDUCTION APPARATUS FOR LIGHTING BY ELECTRICITY.

Specification forming part of Letters Patent No. **210,317**, dated November 26, 1878; application filed September 30, 1878.

*To all whom it may concern:*

Be it known that I, JIM BILLINGS FULLER, of Brooklyn, New York, have invented a new and useful Improvement in Electro-Magnetic Apparatus, for the distribution of electric currents, for electric illumination, and other similar purposes, of which the following is a specification:

The object of this invention is to operate along the line of a main electric circuit a large number of small lights, each being placed in a local circuit, whose currents are caused by the action of the currents in the main circuit upon magnets of peculiar construction, around the poles of which the local currents flow.

The nature of the invention will be understood by the following description.

In the drawings, Figure 1 represents a side elevation of the apparatus connected for a single light, without the governor. Fig. 2 is a top section, and Fig. 3 an end elevation, of the same. Figs. 4 and 5 represent plans of such apparatus connected for two and four lights, respectively. Fig. 6 shows the mode of arranging along a line several such apparatus. Figs. 7 and 8 represent elevations, at right angles to each other, of such apparatus, with the lamps and governors.

I employ for this invention two magnet-cores, arranged parallel with each other, and connected magnetically at the ends, as shown. Around the center of each of these cores is a soft-iron head, and at a proper distance from each side of this is a head of insulating material. The outer ends of these cores are coiled with insulated copper wire, and so connected together and to the electric generator as to produce, when in action, two consequent opposite magnetic poles, at N and S. A, B, C, D, and E represent the connections of these coils. Between the iron heads and these coils are wound smaller coils of insulated wire, the fineness of which depends upon the tension of the current required.

There is an iron arm, M, hinged to one of the iron heads, so as to swing over upon the seat O, connecting magnetically the poles N and S, as shown in Figs. 7 and 8.

Now, if electric currents be sent through the main circuit, flowing around the large

coils, and rapidly changing, in alternately opposite directions, the magnet-cores will as rapidly change polarity, and these changes will induce in the small coils electric currents of greater or less tension, according to the fineness of the wire composing the small coils.

In the circuit of each of the small coils may be placed a lamp, F, of minimum illuminating capacity, as shown in Fig. 5.

Two small coils may be connected together, parallel or in series, for producing a light of medium capacity, as shown in Fig. 4; or the four small coils may be connected, for producing one light of maximum capacity, as shown in Figs. 1 and 2.

These connections for producing any desired changes in the circuits are made by means of ordinary switches, plugs, or keys, arranged in any convenient manner, and therefore are not shown. The lamps may be of any ordinary kind desired. I prefer, however, those employing luminous points heated to incandescence, rather than those in which the electric arc is produced.

The arm M acts as a governor of the light, by strengthening or weakening the magnetic poles, and thereby varying the strength of the current.

Any number of such apparatus which the electro-motive force of the generator will supply may be arranged along the line of a conductor, the large coils being included in the circuit, and, by means of a switch in the local circuits, each or any lamp may be lighted or extinguished independently from the others.

A magneto-electric machine of any ordinary form which will produce alternating currents may be used in connection with the main circuit.

I am aware that electric lights have been arranged in the secondary circuit of induction-coils of various forms, and therefore do not claim that feature broadly.

I claim—

1. The double electro-magnet herein described, the main coils of which are included in the circuit of a main conductor from a generator of alternating electric currents, producing in said magnet consequent magnetic poles, as shown, and around which poles are coiled helices of wire for receiving the cur-

rents induced by the polar changes, said helices being included in the local circuit with the lamp.

2. The combining of the several polar helices, as shown and described, for producing one, two, or four lights from the same instrument.

3. The connecting-arm M and the seat O, arranged substantially as shown and described, for governing the amount of light.

JIM BILLINGS FULLER.

Witnesses:

JOHN CUMMINS,  
J. N. CRANDALL.