

G. L. HALL.
Machine for Finishing Horseshoe Nails.

No. 210,322.

Patented Nov. 26, 1878.

Fig. 1.
Reduced.

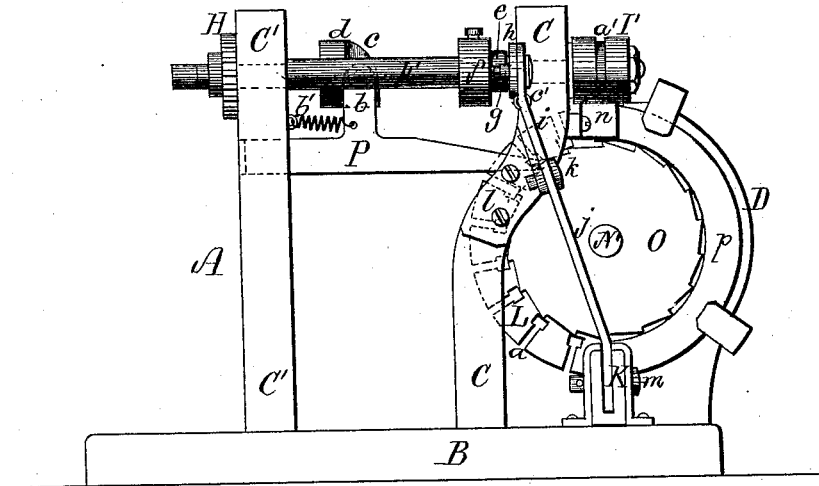
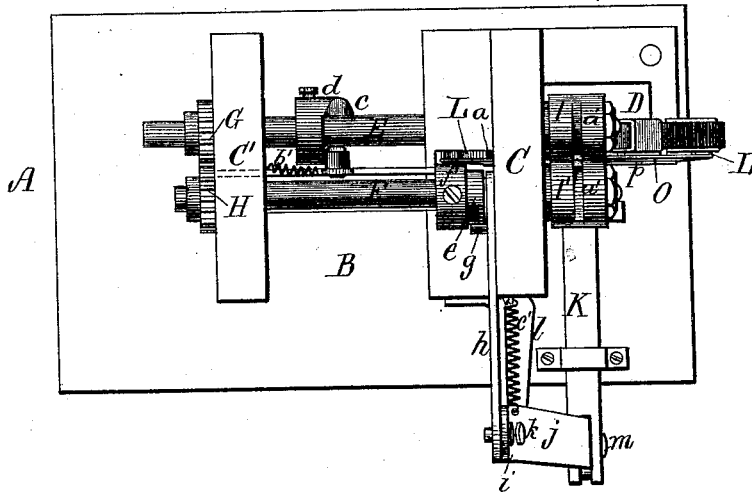

Fig. 2.
Reduced.



Witnesses.
H. E. Lodge
John J. Murphy.

Inventor.
Geo. L. Hall.
H. Curtis. Atty.

G. L. HALL.

Machine for Finishing Horseshoe Nails.

No. 210,322.

Patented Nov. 26, 1878.

Fig. 3.

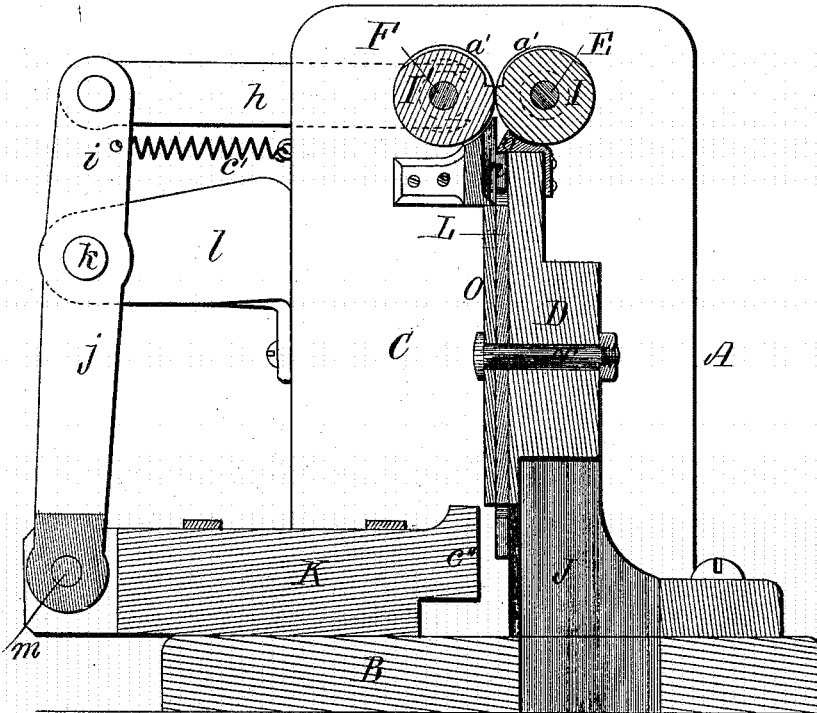
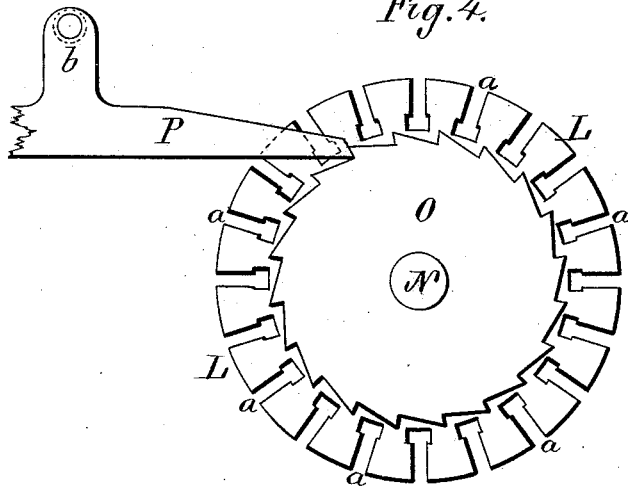

Fig. 4.



Witnesses.
H. E. Lodge
John J. Murphy.

Inventor.
Geo. L. Hall.
J. Curtis. Atty.

UNITED STATES PATENT OFFICE.

GEORGE L. HALL, OF BOSTON, MASSACHUSETTS.

IMPROVEMENT IN MACHINES FOR FINISHING HORSESHOE-NAILS.

Specification forming part of Letters Patent No. **210,322**, dated November 26, 1878; application filed November 9, 1878.

To all whom it may concern:

Be it known that I, GEORGE L. HALL, of Boston, in the county of Suffolk and State of Massachusetts, have invented certain new and useful Improvements in Machinery for the Manufacture of Horseshoe-Nails, of which the following is a specification:

My present invention, as set forth in this specification, relates to mechanism for the production of horseshoe-nails by the combined system of preliminary swaging and final punching or trimming, the thickness of the nail and its head being completed by the first and the pointing and trimming by the latter; and my invention consists, in the main, in the employment, in connection with the preliminary swaging-dies and the final trimming or finishing die, of a rotary index-wheel or carrier, provided with equidistant peripheral notches or pockets to receive and steady the nails, and intermittently advancing in one direction only, as hereinafter described.

The drawings accompanying this specification and illustrating my invention represent, in Figure 1, a side elevation, in Fig. 2 a plan, and in Fig. 3 a vertical cross-section, of a machine embodying my improvement. Fig. 4 of said drawings represents a side view of the nail-carrier and its ratchet-wheel.

In the above-named drawings, the letter A represents the frame of the machine, the same consisting of a horizontal base or bed plate, B, and two upright standards, C C', erected upon such base, while D represents a third upright standard or abutment, which constitutes the seat of the trimming-die and the support of the nail-carrier, such abutment D being situated immediately in front of and at right angles to the front standard, C, and being firm and solid in character.

Two parallel horizontal shafts, E F, are mounted in bearings in the upper part of the standards C C', and are put in rotation by the impulse of a pulley fixed to the first, E, which thus becomes the driving-shaft of the machine, motion being transmitted from it to the shaft F by twin gears, G H, mounted upon the two, as shown in the drawings.

To the front end of each shaft E F, as it protrudes beyond the front face of the stand-

ard C, I affix a cylindrical hub or roller, I or I', these hubs being of like form and size, and so arranged that their peripheries travel in close proximity to each other in opposite directions, while each hub or roller has a circumferential twin-shaped channel, a', which channels coincide one with the other, and operate to swage between them and reduce a nail-blank to the requisite thickness as to its body and complete its head, and to reduce such nail in part to the desired width, leaving its point to be completed by the final trimming-die.

The said trimming-die, through which the nail is finally crowded to complete its manufacture—that is to say, to trim its side edges, and thereby complete its point and remove the burrs or excess of metal left as it emerges from the roller-dies I I'—is shown at J as located in the lower part of the abutment D, below the index-carrier and the other operative parts of the machine in general, while a plunger, K, is disposed upon the top of the bed-plate B, and at right angles to the plane of the abutment D, and operates with the die J to crowd a nail through the latter at each advance.

The employment of roller swaging-dies to reduce a nail-blank to its general form, and of the die and plunger to complete the shape of the nail, constitute in themselves no part of my present improvement, but are only elementary features which go toward making up an entire operative machine, and co-operate with and make available the rotary index-wheel or carrier, which I consider to be the chief feature in my invention. Such roller swaging-dies and the punch-die and plunger have heretofore, under varying arrangements, been embodied in Letters Patent issued to myself and others for machinery for the manufacture of horseshoe-nails.

In carrying my present invention into practice, I provide a circular flat plate or disk, L, of a thickness somewhat in excess of that of the head of a nail produced by the dies I I'. and I pivot this plate L to the front face of the abutment D, and below the said dies I I', by a horizontal bolt or stud, N, in such manner that the said plate L is permitted to rotate in one direction upon its pivot, but with such

a degree of friction between them or with respect to the abutment as shall prevent accidental slipping or derangement of the plate upon its support.

Proceeding, I form in the periphery of the plate L a series of equidistant radial notches or pockets, *a a*, &c., each pocket in general form corresponding to the head and upper part of a nail produced by the dies I I', which it is destined to receive, the enlarged portion of each notch designed to receive the head of a nail being nearest the axis of the carrier, in order that the head of the nail resting in this enlargement of the notch shall prevent escape of the nail when, by the advance of the carrier, the position of the nail has become reversed, end for end, and its point is presented downward.

The plate L constitutes an intermittingly-advancing rotary carrier or carriage for transferring the nails, as they emerge in regular succession from the dies I I', to the punch-die J, and each of the notches or receptacles *a*, in its appointed order, receives a nail point upward, and presents it point downward in front of the said trimming-die J, the operation of swaging the nails, their descent into the notches of the carrier, their arrival in front of the trimming-die, and their final passage into and through the latter being carried on in regular continuity, and the movements of the various parts of the machine being automatic after the nail-blank is fed between the roller-dies by the attendant.

It is, of course, essential that intermittent rotary advances in one direction be imparted to the carrier L, in order that it may halt while a nail is being precipitated into one of its notches from the roller-dies above, and then advance to carry this nail one step in its journey to the final die, and present the next succeeding notch under the grooves of the roller-dies, so as to receive the next descending nail, and also in order to permit the plunger K to advance and crowd a nail from one of the notches into the trimming-die J, the respective movements of the roller-dies and plunger being so timed with respect to those of the carrier that with each halt of such carrier the said rollers swage and drop a nail, and the plunger effects an advance and retreat movement.

To carry out these essential movements I proceed as follows: To effect the intermittent advances in one direction only of the carrier L, I affix to its front face a ratchet-wheel, O; and to operate this ratchet-wheel I employ a horizontal driving-dog, P, sliding in guides formed in the standards C C', and arranged below the shafts E F, such dog having an upright arm, *b*, which stands in front of and is operated by the cam-face *c* of a hub, *d*, affixed to the shaft E, the arm *b* being crowded against the said cam-face *c* by a spring, *b'*, suitably applied.

To effect the requisite reciprocating movement of the plunger K toward and from the

base B, and with respect to the die J, with which it operates, I employ a wiper-cam, *e*, formed upon the front end of a hub, *f*, which is mounted upon the shaft F, such cam *e* impinging against a stud, *g*, extending laterally from the inner end of a horizontal rod or bar, *h*, which is forked, and straddles at its inner end the said shaft F, to find one bearing or support, while its opposite and outer end is pivoted to the upper end of the upper and shorter arm, *i*, of an upright lever, *j*, which, in turn, is fulcrumed, as shown at *k*, to the outer extremity of a bracket, *l*, projecting from the front side of the standard C, the said arm *i* being crowded toward the shaft F by a spring, *c'*, properly applied, in order to maintain the stud *g* in contact with the cam *e*, while the lower end of the lever *j* is pivoted, as shown at *m*, to the outer end of the plunger or follower K, before described.

It is obvious that rotations of the shaft F and cam *e* (simultaneously with those of the shaft E and cam *c*) will, through the instrumentality of the bar *h*, lever *j*, and spring *c'*, effect reciprocating movements of the plunger K toward and from the bed-plate with respect to the carrier L and its notches *a* and the passage J, and the extent of the forward movement of said plunger is such as to push a nail from the coinciding notch of the carrier out of such notch and into the coinciding passage J, the respective positions and functions of the cams *c* and *e* in relation to the dies I I', the carrier L, and plunger K being so calculated or timed that as the carrier halts in receiving a nail, as before explained, the plunger advances and drives the nail from the notch opposite it, it being observed that the plunger is placed in such a position with respect to the carrier and the passage J that as the carrier stops one of its notches *a*, the passage J, and the nose *c''* of the plunger are in alignment.

To temporarily receive a nail as it is precipitated from between the rollers I I', I place alongside the upper part of the carrier L, and immediately below the rollers, a tunnel or guide, *n*, which constitutes a chute, to deflect the nail as it is delivered head downward from the rollers, and guide it into coinciding notch *a* of the carrier. The bottom of the guide *n* should be sloping, as represented, the more effectually to guide the nail into the notch, while, if deemed necessary, a reciprocating plunger or a spring-latch may be employed to operate with the guide and the carrier to impel the nail with a positive movement into the notch.

A shield, *o*, is placed over the periphery of the carrier L below the roller-dies, to prevent entanglement of the nails as they are delivered from such rollers with the peripheral notches of such carrier, and to divert the nails into the chute or guide *n*; while, to maintain the nails in place within the notches *a a*, &c., of the carrier as the latter revolves, and before the punch-passage J is reached, I employ an annular or semi-annular shield, *p*, placed in

front of the outer portion of the carrier, and which terminates or is open at a point immediately opposite the passage J.

The mode of operation of my improved machinery will be fully understood from the foregoing description, and does not require to be further set forth.

The details of mechanism which I have explained as one means of effecting the movements of the nail-carrier L in consonance with those of the roller-dies and the plunger K are susceptible of change or substitution without losing sight of the essential feature of my invention, and I do not restrict myself in any sense to such details, as it would require but the exercise of ordinary skill on the part of a mechanic to change or avoid them altogether, and yet effect the requisite movements of the elementary features of the machine.

I claim as my invention, and desire to secure by Letters Patent of the United States, as follows:

1. The combination, substantially as hereinbefore set forth, of the swaging-dies, the intermittingly-moving pocket or carrier wheel, and the finishing-die and punch or plunger.

2. The guide *n*, in combination with the dies I I' and carrier L.

3. The shield or guard *o*, in combination with the guide *n*, carrier L, and dies I I'.

4. In combination with the roller-dies, the carrier-wheel, and the reciprocating plunger or punch, the shafts E F, the cams thereon, and intermediate mechanism for communicating the proper intermittent motion from said cams to the carrier-wheel and the punch, substantially as set forth.

GEO. L. HALL.

Witnesses:

F. CURTIS,
H. E. LODGE.