

J. F. McNALLY.  
Engraving-Machine.

No. 210,348.

Patented Nov. 26, 1878

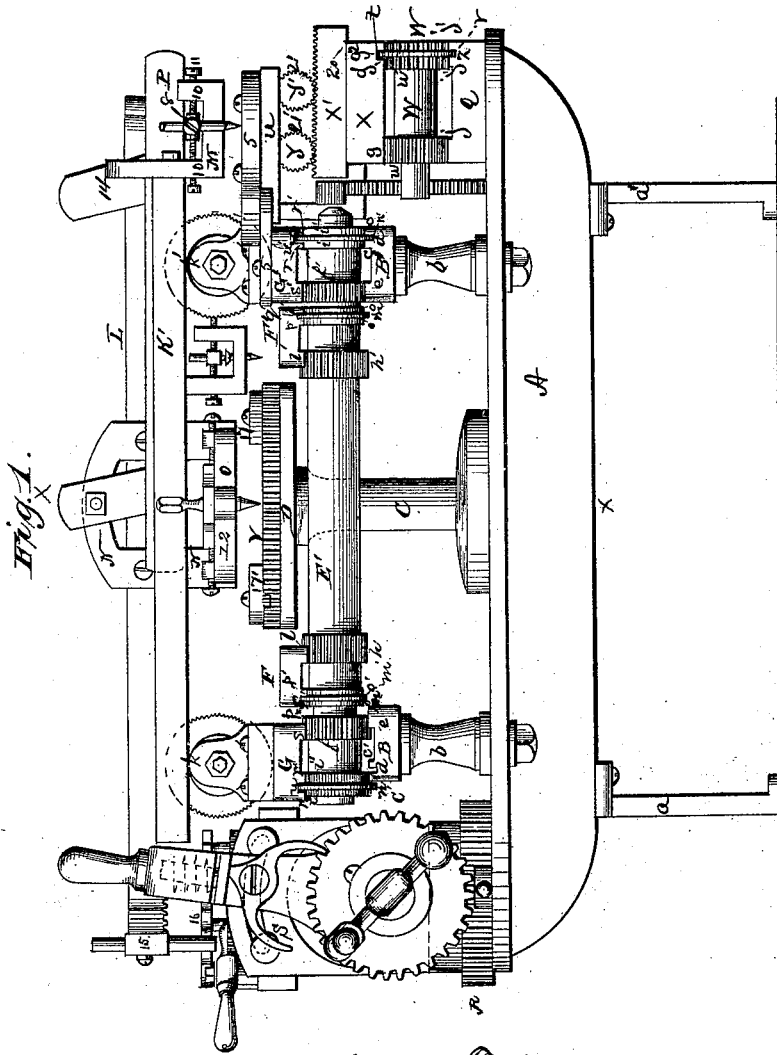

WITNESSES  
*Frank L. Curand*  
*H. Aubrey Toulmin* BY

*James F. McNally*  
 INVENTOR by

*Amos O'Neill*  
 Attorney



J. F. McNALLY.  
Engraving-Machine.

No. 210,348.

Patented Nov. 26, 1878.

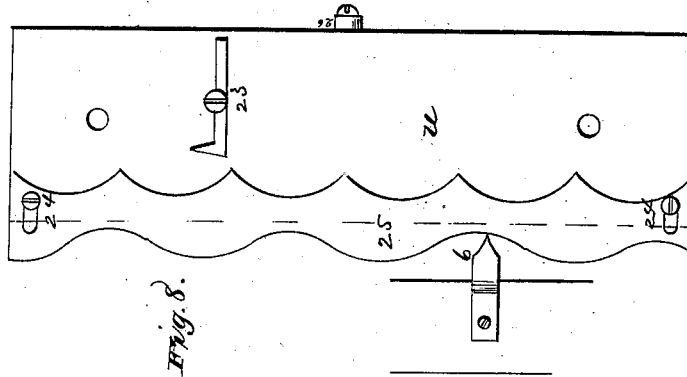

Fig. 8.

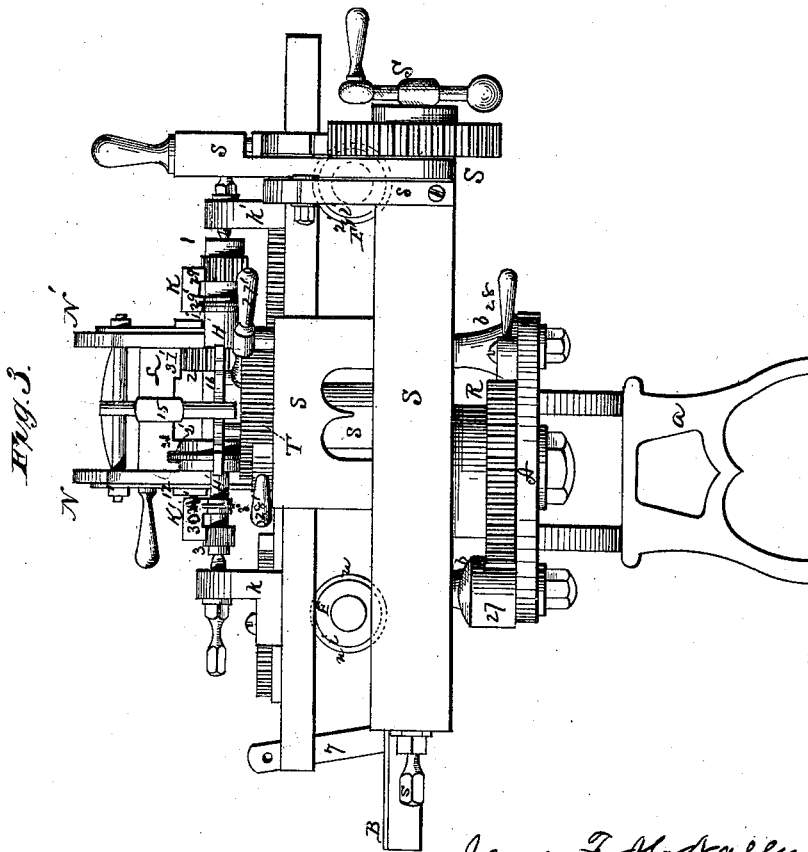

Fig. 3.

James F. McNally  
INVENTOR by

WITNESSES  
Frank L. Curran  
H. Aubrey. Tinsman

By  
O. O. Keill  
Attorney

J. F. McNALLY.  
Engraving-Machine.

No. 210,348.

Patented Nov. 26, 1878.

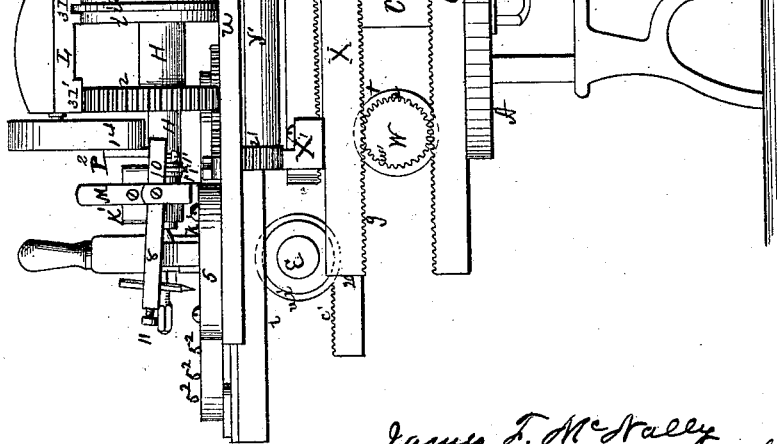
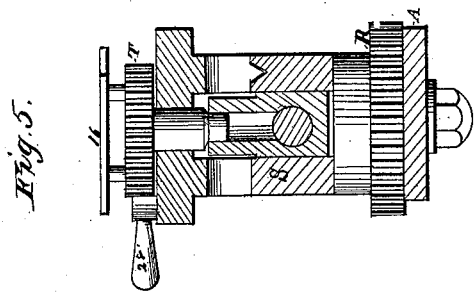

WITNESSES  
*Frank L. Curand*  
*W. Aubrey Toulmin* By

*James F. McNally*  
 INVENTOR by  
*Am. O. O'Neill*  
 Attorney.

J. F. McNALLY.  
Engraving-Machine.

No. 210,348.

Patented Nov. 26, 1878.

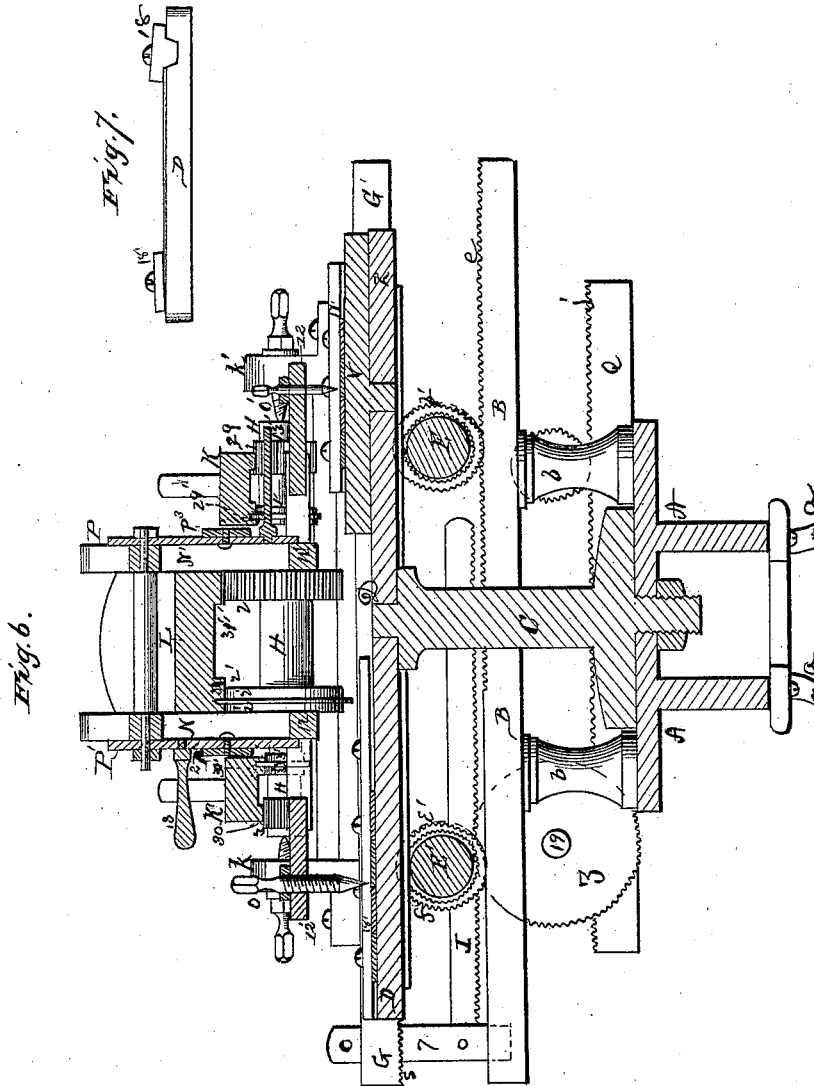

WITNESSES  
*P. L. Curand*  
*H. Hubrey, Treasurer*

*James F. McNally*  
INVENTOR *by*  
*John D. O'Neill*  
ATTORNEY

# UNITED STATES PATENT OFFICE.

JAMES F. McNALLY, OF WASHINGTON, DISTRICT OF COLUMBIA.

## IMPROVEMENT IN ENGRAVING-MACHINES.

Specification forming part of Letters Patent No. **210,348**, dated November 26, 1878; application filed June 3, 1878.

*To all whom it may concern:*

Be it known that I, JAMES F. McNALLY, of Washington city, in the county of Washington and District of Columbia, have invented certain new and useful Improvements in a Machine for Engraving on Metals and Enlarging or Reducing the Copy; and I do hereby declare that the following is a full, clear, and exact description thereof, which will enable others skilled in the art to which it pertains to make and use the same, reference being had to the accompanying drawing, and to the letters of reference marked thereon, which form a part of this specification.

My invention relates to improvements in machines for engraving on metals and other materials; and consists of two carriage-ways, which are milled and grooved on the upper side, resting and secured on short substantial columns rising from the ordinary machine-bed, to which they are made fast; two adjustable gearing roller-shafts of equal length and diameter, provided at each end with two sets of bands and milled wheels, one set of which mesh into and operate on the carriage-beds; two adjustable tables, on which the work is made fast, also milled and grooved on the under side, meshing into and working on the inner set of milled bands on the roller-shafts; two carriages milled and grooved on the under side, which mesh into and work on the outer set of milled wheels on the adjustable gearing-rollers. Surmounting these carriages are two reciprocally-moving revolving shafts, provided with the bands and milled wheels that carry the time-carriage and diamond bars. One of these carriages is provided with a stud and a milled connecting-bar; a time-carriage, also milled and grooved on the under side, and provided with two tracers, one on either side; two diamond-lifting levers and a guiding-rest; two diamond-bars, grooved and milled on the under side, one having one and the other having two diamond-holders; the usual index-plate, fixed to a stationary table, provided with two adjustable clamps for holding the work to be copied; a reciprocating combination carriage, upon which the copy may be enlarged or reduced, consisting of a carriage-way attached to the bed of the machine, grooved and milled

on the upper side; two short roller-shafts, milled at one end and milled and tongued at the other. On one of these rollers is secured a large milled wheel; a frame-carriage, grooved and milled on the under side, and provided with two pillow-blocks, the tops of which are milled and grooved; two roller-shafts that adjust in the pillow-blocks, milled and tongued at one end and milled at the other; a simple metal table, grooved and milled on the under side, and arranged to hold two indexes, one at each end, and having screw-holes, that a former may be screwed thereon; an adjustable graduating-machine, provided with formers and an index governed by a lock-nut. The whole is designed to do any kind of engraving on metal in any atmosphere, and with the same facility either reduce or enlarge the copy, at the will of the operator, or produce three sizes of the same figure at the same time without readjusting the machine, and is operated like other engraving-machines, all of which will more fully appear hereinafter, reference being had to the drawings and specification.

Similar letters of reference indicate corresponding parts.

Figure 1 is a front elevation, showing also the end of the graduating-machine and the reciprocating combination carriage. Fig. 2 is a plan of the machine. Fig. 3 is an end elevation, showing the graduating-machine, index thereon, and marker, the end of the time-carriage, diamond-bars, and one of the triple-gear time-roller shafts. Fig. 4 is an end elevation of the machine, being a side elevation of the combined reciprocating carriage, showing the other end of the time-carriage, diamond-bars, diamond-point holders and lifters, and the other triple-gear time-roller shaft. Fig. 5 is a vertical section of the index on the graduating-machine. Fig. 6 is a vertical cross-section of the machine, taken at the points *x*, seen in Figs. 1 and 2. Fig. 7 is the clamp to hold the work, showing a straight-edge. Fig. 8 is the reciprocating combination-carriage table, having a former screwed in place and bearing against a rest.

A is an ordinary machine-bed, of proper size and strength, supported on feet *a a'*, by which it can be screwed to the floor. Secured on

this machine-bed, and equidistant from each other, are four short substantial columns, *b b*, on the top of which are fastened two carriage-beds, *B B'*, lying parallel to each other. On the upper side of these carriage-beds, near the outer edges when in position, are two parallel bands, near each other, *c c'*, so arranged as to form between them a slightly-beveled groove, *d*, their entire length, and on the inner edge runs a slightly-elevated band, *e e*, milled about half its length, continuing thence to the end as a plain band. Great care must be exercised in adjusting these beds, as upon their accuracy depends, in a measure, the steadiness of the machine.

*E E'* are adjustable gearing-shafts, of equal length and diameter, and constructed alike, that take their bearings on the carriage-ways *B B'*, one on each side of the center column, *C*, having at the ends friction-shoulders *i i'*, with a friction-tongue, *n n'*, rising therefrom, and near them an elevated milled band, *f f'*, which corresponds with, rests on, and meshes into the bands *c c'*, grooves *d*, and milled bands *e* on the carriage-beds *B B'*, for the accommodation of the shafts *E E'*. The carriage-beds are so placed that when the tongue *n'*, at one end of the shafts *E E'*, meshes into the groove *d* on the carriage-bed *B'*, the tongue *n*, at the other end of the shafts *E E'*, passes beyond the outer friction-shoulder, *e'*, of the carriage-bed *B*, thus preventing locking or binding by the contraction or expansion of the shafts *E E'*, and to overcome the contraction and expansion of the metal carriages *F F'* and *G G'* that ride on the roller-shafts *E E'*.

On roller-shafts *E E'* are two inner sets of gearing-bearings, consisting of friction-shoulders *o o'*, having tongues *m m'* rising therefrom, and milled bands *h h'*, on which adjust and work two metal platforms, *F F'*, that form part of the table on which the work to be copied rests. On the under side of platforms *F F'* are friction-shoulders *p p'*, forming grooves *q q'*, and milled bands *l l'*, that correspond with, work on, and mesh into the inner set of gearings on the roller-shafts *E E'*. The milling on these tables *F F'* and inner set of gearings on the shafts *E E'* is finer than the milling at the ends of the shafts, so that, while the platforms *F F'* move with the carriages *G G'* that ride on the same shafts, they necessarily move slower, acting as a check on the movements of these parts, and add steadiness to the machine, and at the same time facilitate the execution of larger work at one operation.

Carriages *G G'* are of equal size and weight, and provided on the under side with two friction-bands, *r r'*, forming grooves *u u'*, and a slightly-raised milled band, *s s'*, all running the full length of the carriage. These carriages are placed parallel to each other on the ends of the shafts *E E'*, which are separated only sufficiently far apart to give steadiness to the carriages, and immediately over and

parallel with the carriage-beds *B B'*, so that when the tongue *n'* on the roller-shafts *E E'* meshes in the groove *d* in carriage-bed *B'* it will at the same time mesh in the grooves *u u'* in the lower side of carriages *G G'*. Both carriages *G G'* ride on and mesh into the grooves and millings on the shafts *E E'*. Carriages *G G'* are surmounted each by two stationary heads, *k k'*, each set bearing a revolving shaft, *H H'*, carrying three sets of gear-wheels each—that is to say, a small-sized milled band, 3, accompanied by a wheel, 3', from which rises a friction-tongue, on which diamond-bar *K'*, having a corresponding milled band and a friction-groove, rides; a large milled band or wheel, 2, accompanied by a wheel, 2', from which rises a friction-tongue, (on this rests time-carriage *L*, having a milled band and friction-groove to correspond therewith;) a medium-sized milled band or wheel, 1, accompanied by a wheel, 1', of the same diameter, from which a friction-tongue rises, (on this rests the diamond-bar *K*, also having a milled-band and friction-groove to correspond.) These two shafts are to be nicely adjusted, as upon their accuracy and the steadiness with which they carry the diamond-bars and time-carriage depends in a great measure the accuracy of the work done. They work on centers in the heads *k k'*, and are secured in place by check-nuts. Carriage *G'* is also provided with an adjustable perforated stud, 4, through which, by toggling it onto the elongated arm of the index 5, connection is formed and one motion communicated to the reciprocating combination carriage. Carriage *G'* is also provided with an L-shaped bracket, 7, to which a bar, *I*, milled on the under edge, is pivoted. This bar *I* meshes into and works on the wheel *Z* of the reciprocal carriage, conveying to it from the large machine another movement.

Diamond-bars *K K'* are nicely-adjusted metal bars of sufficient length and weight, provided on the under side with elevated milled bands 29 30 and friction-grooves and shoulder-bearings 29' 30' their entire length, and at one end with L-shaped brackets *M M'*, in which the diamond-holders 8 8', working on centers 10 10', are secured by set-screws 11 11'; and diamond-bar *K* has an additional bracket, *M*<sup>2</sup>, secured to the side between the gearings *H H'*, in which diamond-holder 8<sup>2</sup> is secured and works. These diamond-bars are nicely adjusted on the double gearings on shafts *H H'*, one riding the smaller set, the other the medium. They are adjuncts to the time-carriage *L*, and are governed by the operator, who conveys the motion he desires to the time-carriage, and thence to the diamond-points through the diamond-bars *K K'*, each of which has its own time and length of stroke.

The time-carriage *L*—a metal bar larger and wider than the diamond-bars—is provided on the under side with an elevated milled band,

31', and friction-groove and shoulder-bearings 31 its entire length, with two suspended arbors, N N', secured to its sides midway between the ends, from which project two arms, each at right angles, 12 12', so arranged as to hold by set-screws two tracing-handles, O O'; also, pending from the top of the arbor, where they are secured by pivot-joints, are two lever-arms, P P', into which cranks 13 13' are secured for adjusting the lifting-levers P<sup>2</sup> P<sup>3</sup>. One end of the lifting-levers P<sup>2</sup> P<sup>3</sup> is pivoted to the arms P P' just above the crank-handles 13 13', the other ends extending to or beyond the end of the time-carriage, where they are pivoted to oscillating arms 14 14', working near the end of the time-carriage, and rest on projections on the diamond-holders 8 8' 8<sup>2</sup>, controlling their cut or throwing them out of gear, at the will of the operator.

On the opposite end of the time-carriage L is an adjustable rest, 15, secured by a set-screw that can be thrown in contact with a former, 16, on the graduating-machine. This carriage must be of sufficient strength and firmness to prevent any springing or giving whatever, and yet must be sufficiently light not to give too great a momentum to the machine, and to be under complete subjection to the will of the operator. No deviation can be permitted in the construction of this part, or the copy produced will not be accurate.

A heavy substantial column, C, supported on a broad base and terminating in a broad crown, rises from the machine-bed A. Upon this column the tracing-table D—a metal field of suitable size, being as long or longer than the machine is wide—is secured and rests. On the top and at one end of tracing-table D is secured an index, V, furnished with a set of clamps, 17 17', to hold the work to be copied. On the other end of the tracing-table is another set of clamps, 18 18'. The clamps 17 and 18 are provided with an underlying straight-edge, against which the work can readily be adjusted.

The machine thus far described is a complete engraving-machine, upon which can be executed any character of work that can be done on any machine now in use. To this, however, I add a combination, upon which the work may be enlarged or reduced, and a graduating-machine, as follows: A frame carriage-way, Q, milled on the upper edges of the side pieces *j j'*, having a groove, *z*, cutting through the milled face of the side piece *j'*, its entire length, is secured to the machine-bed A. On this carriage-bed two roller-shafts, W W', having slightly-elevated milled bands *w w'* on their respective ends, with a friction-tongue, *v*, rising from the milled bands *w*, are placed about one-fourth the length from each end, the milling on the rollers and the tongue *v* meshing into the milling and groove on the carriage-bed. A large wheel, Z, milled on its periphery, is secured on shaft 19 of the gear-roller W', meshing with the milled surface on the arm I, attached to the larger machine,

through which a reciprocal motion is carried from one machine to the other. On these roller-shafts W W' is adjusted a frame-carriage, X, milled on the under edges *g g'*, and having a groove, *g<sup>2</sup>*, to correspond with the groove *z* in the carriage-way Q, all meshing with the milled bands *w w'* and tongue *v* on the rollers W W'. Carriage X is surmounted by two pillow-blocks or heads, X<sup>1</sup> X<sup>2</sup>, firmly secured thereon, and provided with an adjustable lock, 20. The upper edges of the pillow-blocks X<sup>1</sup> X<sup>2</sup> are milled, and in the milling on the block X<sup>2</sup> a groove, *y*, is cut its entire length. Adjusted on the pillow-blocks are two gear-rollers, Y Y', having milled bands 21 21' at both ends, and a friction-tongue, 22, rising from the milled band at one end, so that the milled bands and tongue mesh and gear into the milling and groove on the pillow-blocks X<sup>1</sup> X<sup>2</sup>. U is a plain metal table, milled and grooved on the under side, to mesh in and gear on the rollers Y Y', provided with two indexes, 5 5', one on each end, on the top a finger-indicator, 23, and screw-holes 24, by which a former, 25, may be screwed to the table, also a pendent finger, 26, to which a spring may be attached. Index 5' is a round disk, milled on its periphery, while the index 5 is pear-shaped, or has an elongated neck, perforated to toggle on the stud 4, through which the combination carriage is connected with the larger machine. R is a large index, milled on its periphery, working on a pivot or center operating through the machine-bed A, and governed by a lock-nut, 27, and is surmounted by a graduating-machine, S, of the usual form and construction. On the top of the graduating-machine is an index, T, governed by a lock-nut, 27', and carrying a former, 16. Two finger-indicators, 28 28', to point out the movements of the indexes, are attached to the graduating-machine in juxtaposition with indexes R and T. The index R and graduating-machine S are so arranged and adjusted as to be placed in any angle desired and to put the former 16 in any degree of angle.

When the various parts of my machine have been constructed and properly adjusted in their respective places consecutively as I have named and described them—observing to put the gear-rollers E E' on the carriage-beds B B', one on each side of the column C, about one-fourth the length of the carriage-beds of the respective ends, meshing the friction-tongue *n'* into the groove *d'* in carriage-bed B', permitting the groove *n* at the other ends to pass beyond the groove outside of friction-band *c* of carriage-bed B, adjusting the platforms F F' and carriages G G' so that their ends will come flush with the side of the machine, and arranging all the other parts uniformly in place—by my method of milling, tonguing, and grooving, and the peculiar construction of the various parts, together with my novel mode of cross-gearing, each piece of the machine confines the other until the



whole—though each part is independent—is combined and secured into one complete machine, obedient to the will of the operator.

By the peculiar adjustment and construction of my machine no part or joint can bind nor in any manner be effected by expansion or contraction. It will work in any temperature or atmosphere without readjusting. As it starts from inertia at the will of the operator, and the parts are constructed to neutralize the momentum generated by motion, and as no part is confined, my machine cannot lock, bind, nor kick, and is entirely obedient to the hand and will of the operator.

This machine can be operated from either side, working over its entire field without readjusting. It will do three sizes and styles of work at the same time, and by one operation, with accuracy; and by the arrangement of the formers at both ends the machine, by one movement, will produce lines crossing each other, creating figures, circles, and ovals at the same time.

Having now described my invention, what I esteem as novel, and desire to protect by Letters Patent, is—

1. In an engraving-machine, carriage-beds B B', having milled bands *e*, friction-bands *c*, and groove *d*, substantially as shown and described, and for the purpose set forth.

2. In an engraving-machine, carriage-beds B B', having bands *e*, milled part their length, groove *d*, formed by two friction-bands, *c c'*, when resting and secured on columns *b b'*, substantially as described, and for the purpose set forth.

3. The rollers or gear-shafts E E', of uniform size, having two sets of milled and friction bands, with a friction-tongue rising from the latter at each end, substantially as shown and described.

4. The adjustable plain metal platforms F F', having friction-shoulders *p*, groove *q*, and milled bands *l*, substantially as shown and described, and for the purpose set forth.

5. The carriages G G', having on the under side friction-bands *r*, groove *u*, and milled bands *s*, and surmounted by two stationary heads, *k k'*, supporting a triple gearing-shaft, H H', on which are carried three sizes and sets of gear-wheels, substantially as shown and described.

6. The gearing-shafts working on centers in stationary heads *k k'*, and carrying three sizes of milled wheels, and accompanying friction-wheels, having tongues rising therefrom, all arranged substantially as shown, and for the purpose described.

7. The carriage G', milled and grooved on the under side, carrying stationary heads *k k'*, gearing-shaft H, provided with a stud, 4, and bracket 7, substantially as shown and described.

8. The roller-shafts E E', having two sets of gearing at each end, in combination with carriage-beds B B', substantially as shown and described.

9. The roller-shafts E E', having double sets of milled and friction gearings at each end, in combination with carrying-platforms F F', milled and grooved on the under side, substantially as shown and described.

10. The roller-shafts E E', in combination with carriages G G', constructed as described, substantially as shown, and for the purpose set forth.

11. The roller-shafts E E', with two sets of milled and friction gearings at each end, in combination with carriage-beds B B', platforms F F', and carriages G G', substantially as shown and described.

12. The revolving gearing-shafts H H', working on centers, provided with three sizes of gearing-wheels, milled on their periphery, three corresponding friction-wheels, having friction-tongues rising therefrom, in combination with stationary heads *k k'*, fixed on carriages G G', carriages G G', roller-shafts E E', and carriage-beds B B', mounted on columns *b b'*, fixed to a machine-bed, A, substantially as shown and described.

13. The diamond-bar K, having a milled band, 29, friction-shoulders 29', forming a groove on the under side, provided with brackets M<sup>1</sup> M<sup>2</sup>, holding diamond-holder S<sup>1</sup> on the end and diamond-holder S<sup>2</sup> on the side, substantially as shown and described.

14. The diamond-bar K', having a milled band, 30, friction-shoulders 30', forming a groove on the under side, provided with a bracket, M, holding diamond-holder S, substantially as shown and described.

15. The time-carriage L, having a milled band, 31', and friction-shoulders 31, forming a groove on the under side, provided with a rest at the end, and diamond-lifters P<sup>2</sup> P<sup>3</sup> on each side, secured to the arbors N N', to which are also attached on hinge-joints two tracing-handles and two crank-handles for raising and lowering the diamond-lifters, substantially as shown and described.

16. The time-carriage L, milled and grooved on the under side, provided with tracing-handles, diamond-lifters P<sup>2</sup> P<sup>3</sup>, and a rest, in combination with the larger tongued friction-wheels 2 and milled wheels 2', on revolving shafts H H', substantially as shown and described.

17. The time-carriage L, milled and grooved on the under side, provided with tracing-handles, diamond-lifter, and a rest, working on the larger tongued friction-wheel, and milled wheels on revolving shafts H H', in combination with diamond-bar K, working on a smaller set of the tongued friction-wheels 1 on shaft H H', substantially as shown and described.

18. The time-carriage L, milled and grooved on the under side, having tracing-handles, diamond-lifters, and a rest, working on gearing-wheels on shafts H H', in combination with diamond-bar K', riding on a smaller set of gear-wheels, 3, on shafts H H', substantially as shown and described.

19. The time-carriage L, milled and grooved

on the under side, having tracing-handles, diamond-lifters, and a rest when riding on gear-wheels 2 on revolving shafts H H', diamond-bar K, milled and grooved on the under side, having a bracket on the end and one on the side, to support diamond-holders when riding on a set of gear-wheels, 1, on the revolving shafts H H', diamond-bar K', milled and grooved on the under side, having a diamond-holder bracket at the end when riding on a set of gear-wheels, 3, on the revolving shafts H H', in combination with stationary heads *k k'*, carriages G G', milled and grooved on the under side, platforms F F', table D, gear-rollers E E', and carriage-beds B B', supported by columns *b b*, secured to machine-bed A, substantially as shown and described.

20. The diamond-bars K K', having diamond-holders on the end and side, gearing on gear-wheels 1 and 3 on revolving shafts H H', in combination with diamond-lifters P<sup>2</sup> P<sup>3</sup>, time-carriage L, and tracing-table U on the reciprocating carriage, substantially as shown and described.

21. The straight-edged clamps 17 and 18, in combination with table D, arranged substantially as shown and described, and for the purpose set forth.

22. The combination of table D, index V, clamps 17' and 18', and straight-edged clamps 17 18, tracing-handles O, platforms F F', revolving shafts E E', carriage-beds B B', columns *b b*, and machine-bed A, substantially as shown.

23. The combination of time-carriage L, tracing-handles O, platforms F F', tracing-table D, provided with index V, clamps 17' 18', and straight-edged clamps 17 and 18, column C, and machine-bed A, substantially as shown and described.

24. The carriage-way Q, secured to the machine-bed A, grooved and milled on the upper edges, substantially as shown and described.

25. The gearing-roller W, having a milled band at each end, and a friction-tongue rising from one of the bands, and gear-roller W', having a milled band at both ends, with a friction-tongue rising from the band at one end, and a large wheel, Z, milled on its periphery, secured on the other, substantially as described and set forth.

26. The carriage-truck X, milled and grooved on the under side to correspond with the milling and grooving in carriage-way Q and the milling and tongues on rollers W W', provided with head-blocks X<sup>1</sup> X<sup>2</sup>, milled and grooved on the top, substantially as shown and described.

27. The carriage-truck X, milled and grooved on the under side, surmounted by pillow-blocks grooved and milled on the upper edge, in combination with gear-rollers W W', having milled bands at each end, a friction-tongue, V, rising from the milled bands *w'*, and the milled and grooved carriage-way Q, each meshing into and working on the other, substantially as and for the purpose described.

28. The two gearing-shafts Y Y', milled at

each end and having a friction-tongue at one end, substantially as shown and described.

29. The two gearing-shafts Y Y', with milled bands at both ends and a friction-tongue at one end, in combination with the milled and grooved head-blocks X<sup>1</sup> X<sup>2</sup>, in which they mesh and on which they work, carriage X, gear-rollers W W', and carriage-way Q, secured to machine-bed A, substantially as described and set forth.

30. The table U, provided with a finger-indicator, a circular index, milled on its periphery, a disk with an elongated neck, means for securing a former and a pendent finger, when milled and grooved on the under side to mesh in gearing-rollers Y Y', in combination with said gear-rollers Y Y', grooved and milled pillow-blocks, carriage X, milled and grooved on the under side, gear-rollers W W', carriage-way Q, milled wheel Z, milled arm I, bracket 7, and carriage G', substantially as shown and described.

31. The combination of table U, milled circular index 5', a finger-indicator, index 5, with perforated neck, toggling onto stud 4 on carriage G', former 25, rest 6, and diamond-points in diamond-holders 8, secured to diamond-bars K K', substantially as shown and described.

32. The wheel Z, milled on its periphery, in combination with gear-roller W', carriage-way Q, carriage X, pillow-blocks X<sup>1</sup> X<sup>2</sup>, gear-rollers Y Y', table U, milled arm I, bracket 7, and carriage G', substantially as shown and described.

33. The arm I, milled on its under edge, in combination with milled wheel Z, reciprocating combination carriage, carriage G', diamond-bars K K', time-carriage L, and diamond-holders 8 8' 8<sup>2</sup>, substantially as shown and described.

34. The former 25, adjusted to the tracing-table U, in combination with rest 6, substantially as shown and described.

35. The index R, stayed by lock 27, in combination with indicator 28, graduating-machine S, working on a center in the machine-bed A, substantially as shown and described.

36. The index T, carrying a former, 16, stayed by a lock, 28', above the graduating-machine S, substantially as shown and described.

37. The index R, working on a center in the machine-bed A, in combination with graduating-machine S, index T, carrying former 16 and locks 27 27', and indicators 28 28', substantially as shown and described.

38. The combination of index R, graduating-machine S, lock 27, indicator 28, index T, lock 27', indicator 28', former 16, rest 15 on time-carriage L, tracing-handles O, diamond-bars K K', diamond-holders 8, and tables D and U, substantially as shown and described.

39. The combination of the carriage-beds B B', gear-wheels E E', carriages G G', heads *k k'*, gear-shafts H H', gearing-wheels 1 2 3, diamond-bars K K', diamond-holders 8 8' 8<sup>2</sup>, time-carriage L, diamond-lifters P<sup>2</sup> P<sup>3</sup>, rest 15, former 16, index T, lock 27', indicator 28', graduating-

machine S, indicator 28, lock 27, index R, machine-bed A, column C, tracing-table D, having an index and two sets of clamps, with tracing-handles O and platforms F, also the carriage-way Q, roller-shafts W W', gear-wheel Z, arm I, bracket 7, carriage G' and carriage X, blocks X<sup>1</sup> X<sup>2</sup>, gear-rollers Y Y', tracing-table U, indexes 5 5', with diamond-points 8 8<sup>1</sup> 8<sup>2</sup>, and stud 4 on carriage G', all substantially as shown and described.

In testimony that I claim the foregoing as my own I hereto affix my signature in presence of two witnesses.

JAMES F. McNALLY.

Witnesses:

FRANK GALT,  
FRANK L. OURAND.