

D. B. PEEBLES.

Governing and Recording Apparatus for Gas.

No. 210,352.

Patented Nov. 26, 1878.

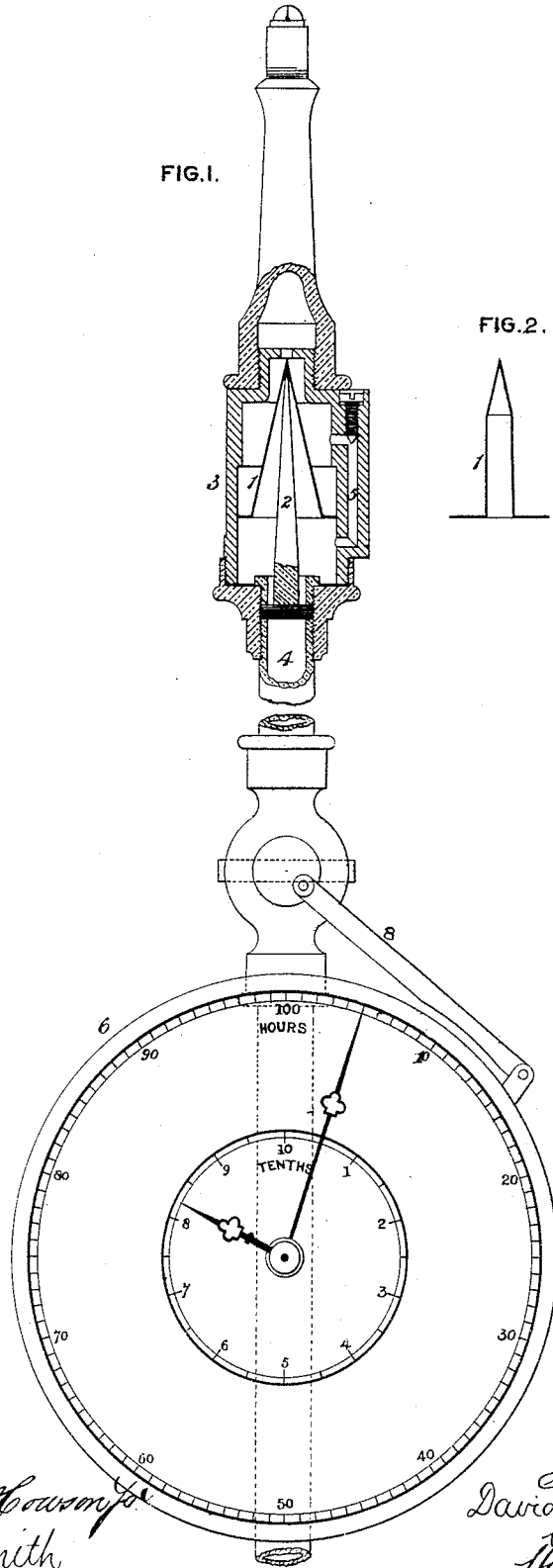

Witnesses
Henry Rowan
Henry Smith

Inventor
David Bruce Peebles
by his Attorneys
Holston & Son

UNITED STATES PATENT OFFICE.

DAVID B. PEEBLES, OF EDINBURGH, SCOTLAND.

IMPROVEMENT IN GOVERNING AND RECORDING APPARATUS FOR GAS.

Specification forming part of Letters Patent No. **210,352**, dated November 26, 1878; application filed November 4, 1878; patented in England, February 23, 1878.

To all whom it may concern:

Be it known that I, DAVID BRUCE PEEBLES, of Edinburgh, in the county of Mid-Lothian, Scotland, have invented certain new and useful Improvements in Governing and Recording Apparatus for Illuminating-Gas, for which I have obtained British Letters Patent, dated February 23, 1878, No. 755, and of which invention the following is a specification:

My invention is applicable to a well-known kind of gas-governor, which delivers a constant volume of gas to one or more burners, and in which a light disk, carrying an upwardly-acting conical valve, is acted on by the inlet-pressure, so as to raise the valve more or less into the exit-orifice. As hitherto made this kind of governor has been very liable to get out of order in consequence of the movable disk sticking either against the side of the chamber in which it works or on the points of support on which it rests when the gas is shut off, and does not bear it up.

My object is to avoid the defects referred to, and also to obtain a time record of the gas passing through the governor. For this purpose I provide a central supporting-point for a movable piece, taking the place of the disk in the arrangements hitherto in use, and I place this central supporting-point considerably above the center of gravity of the piece, the result of which arrangement is that the piece is not liable to stick when resting, while, if it should at any time touch the side of the chamber, it will center itself whenever it comes to rest on the central point, and thereby free itself from the side.

I further connect the stop-cock, by which the gas passing through the governor is let on or shut off, to clock-work, impelled by a spring or weight, and having a balance-wheel escapement, in such a way that the clock-work goes when the stop-cock is open, and by dials records the aggregate time during which the gas is being consumed, but is at rest when the gas is shut off.

Figure 1 of the accompanying drawing is a sectional elevation of my improved apparatus, and Fig. 2 is a section of the internal movable governing-piece as slightly varied in form.

I substitute for the usual flat disk a long

hollow flanged cone, 1, made of tin or vulcanite, or other suitable material, the conical point forming the valve, while a central pointed stud or needle, 2, is provided for the interior of the conical point to rest on when the gas is shut off. The cone 1 works in a cylindrical chamber, 3, in which its bottom flange fits as closely as can be managed without its freedom of movement being interfered with by friction. The gas has access from the inlet-pipe 4 to the space beneath the cone 1, and passes to the upper side of the cone by a lateral passage, 5, fitted with a screw-plug, by adjusting which the rate of flow can be regulated or changed. The lateral passage 5 may be dispensed with, and instead thereof a small hole, or, by preference, two diametrically-opposite holes, may be made in the cone itself for the passage of the gas to the upper side thereof. It is, however, difficult to make such hole or holes in the cone of the precise size that may be required in each case, and the lateral passage 5, with its adjustable plug, is to be preferred. Both expedients—namely, the hole in the movable piece and the lateral passage with adjustable plug—are well known, and I make no claim to them.

The essential points in my movable piece 1 are the hollow conical point, by which the piece can rest on the needle 2, and the situation of this hollow conical point above the center of gravity of the piece; and it is obvious that these features exist equally in the form of cone or movable piece 1 shown in Fig. 1 and in that shown in Fig. 2. In one the conical form is continued down to the bottom flange; in the other the hollow conical point is connected to the bottom flange by a tubular or cylindrical part.

The recording-instrument is in the form of a small time-piece, 6, the works of which are not shown, as they may be of any ordinary kind having a balance-wheel escapement.

The stop-cock of the gas-pipe 4 is connected by a rod, 8, to a frictional stop-slide fitted to the clock-work, so as to bear on and prevent the movement of the balance-wheel when the stop-cock is shut. On opening the stop-cock the balance-wheel is released, and in consequence the instrument records on the dials the

aggregate of the time during which the stop-cock is open, from which the consumption of gas can be calculated.

I claim—

1. The automatic regulating-piece of a constant-volume gas-governor, made in the form of a flanged cone, or flanged tube and cone combined, the point of the hollow cone acting as valve to the exit-orifice, and, when not raised by the gas, resting on a central pointed stud or needle, substantially as hereinbefore described.

2. The combination consisting of the automatic constant-volume gas-governor, with a clock-work movement having a balance-wheel escapement, to which is applied a stopping-slide connected to the stop-cock controlling the gas-supply through the governor, as hereinbefore described.

DAVID BRUCE PEBBLES.

Witnesses:

EDMUND HUNT,
LOCK MOORE.