

W. M. SCOTT & T. BAKER.
Breech-Loading Gun.

No. 210,436.

Patented Dec. 3, 1878.

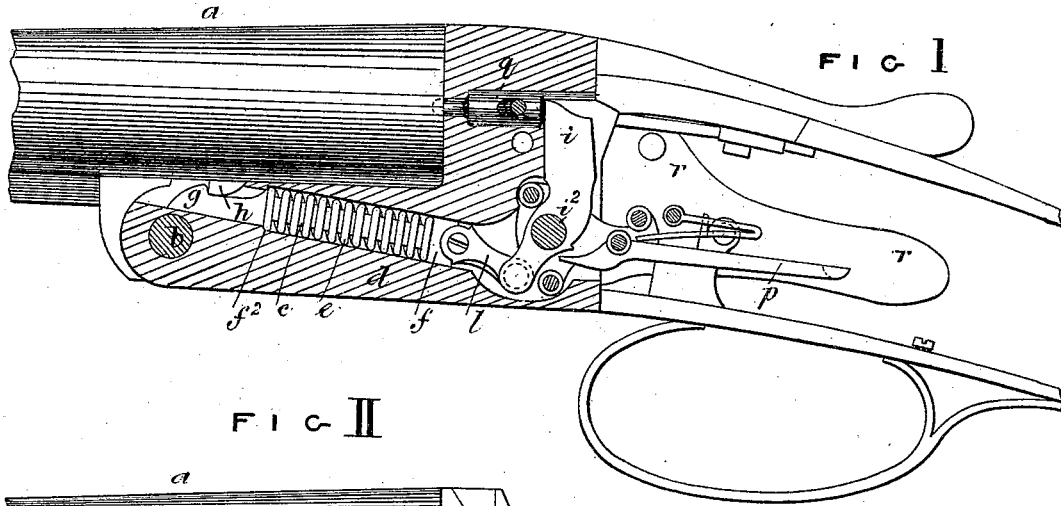

FIG I

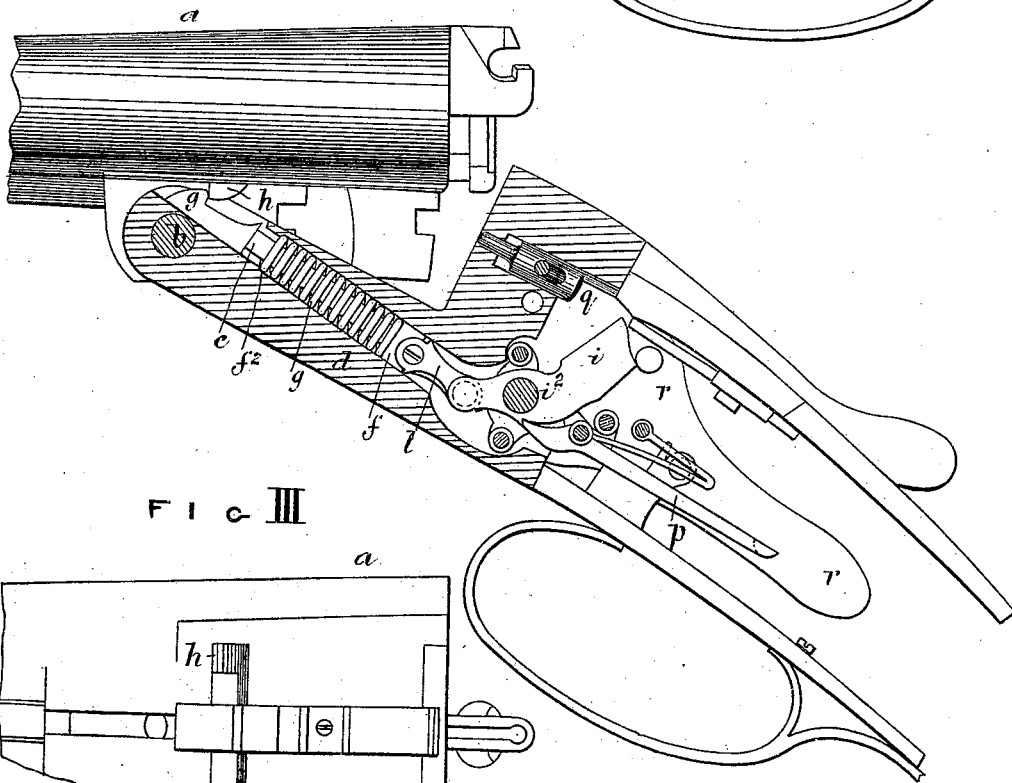

FIG II

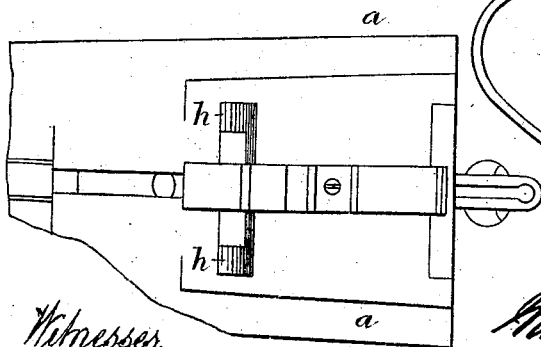

FIG III

Witnesses,
George Shaw
Richard Bennett

Inventors
William Middleton Scott.
Thomas Baker

W. M. SCOTT & T. BAKER.
Breech-Loading Gun.

No. 210,436.

Patented Dec. 3, 1878.

FIG IV

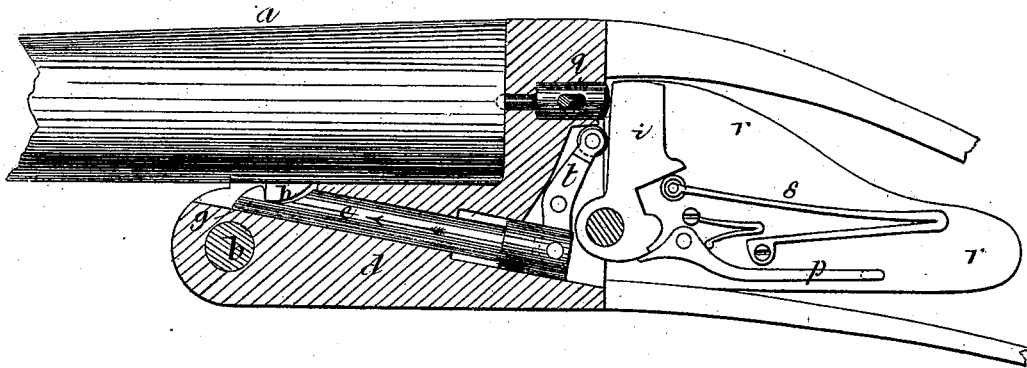
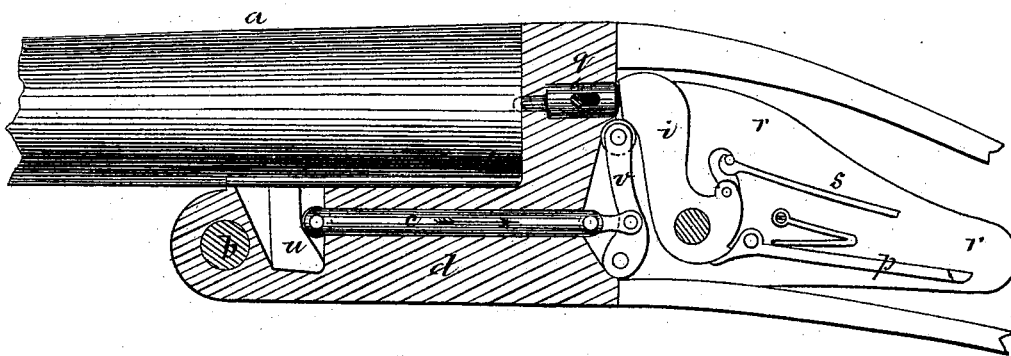

FIG V



Witnesses,
George Shaw
Richard Bennett

Inventors
William Middendorf Scott
Thomas Bolton

W. M. SCOTT & T. BAKER.
Breech-Loading Gun.

No. 210,436.

Patented Dec. 3, 1878.

FIG VI

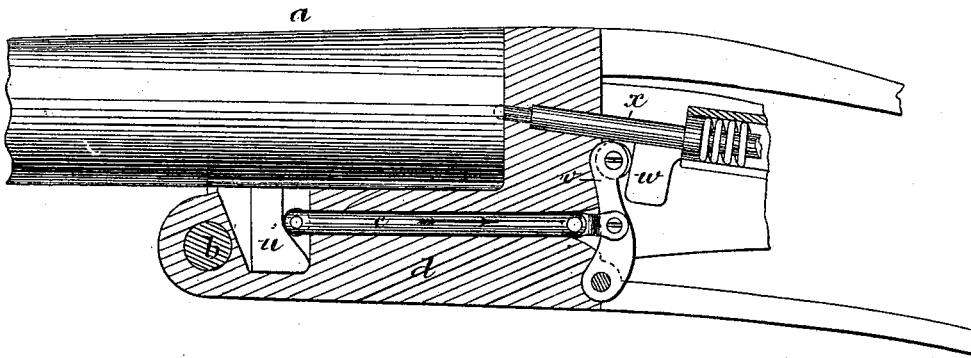
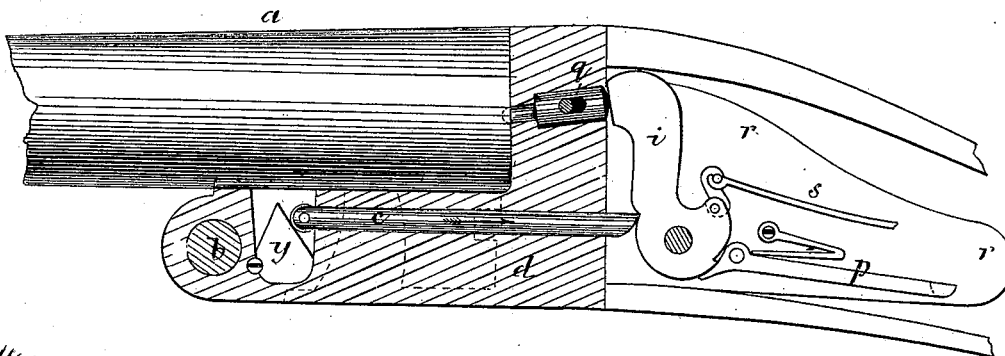

FIG VII



Witnesses,
George Shaw
Richard Kerrett

Inventors
William Marshall Scott
Thomas Baker

UNITED STATES PATENT OFFICE.

WILLIAM M. SCOTT, OF BIRMINGHAM, AND THOMAS BAKER, OF ASTON,
NEAR BIRMINGHAM, ENGLAND.

IMPROVEMENT IN BREECH-LOADING GUNS.

Specification forming part of Letters Patent No. **210,436**, dated December 3, 1878; application filed September 24, 1878; patented in England, February 23, 1878.

To all whom it may concern:

Be it known that we, WILLIAM MIDDLE-DITCH SCOTT, of the firm of W. & C. Scott & Son, of Birmingham, in the county of Warwick, England, gun-manufacturers, and THOMAS BAKER, of Aston, near Birmingham aforesaid, gun-action maker, have invented new and useful Improvements in Breech-Loading Small-Arms, which improvements are fully set forth in the following specification, reference being had to the accompanying drawings.

Our invention relates to breech-loading small-arms of the kind commonly called "drop-down guns;" and consists of the mechanism hereinafter described, by the action of which the cocking of the gun is effected by the act of lifting the breech ends of the barrels and opening the breech for charging the gun.

In double-barrel guns the cocking mechanism constituting our invention is employed in duplicate, the cocking of the hammer of each barrel being effected by independent mechanism.

We will describe our invention in connection with mechanism for cocking the hammer of one of the barrels.

In the body of the gun is a recess, extending from the joint on which the barrels turn to the break-off. In this recess a rod slides, a strong coiled spring around the said rod urging it toward the break-off. The front end of the said rod, or that end near the joint of the gun, is provided with a lug on its upper side. The said lug extends upward to the under side of the barrel. On the under side of the barrel a pin or projection is fixed, which bears against the inner side of the lug—that is, the side turned toward the break-off. When the breech ends of the barrels are raised for opening the breech, the pin or projection described on the barrel performs a curvilinear motion about the joint, and pushes before it the lug on the sliding rod. The said rod is thereby made to slide from the break-off toward the joint of the gun and its coiled spring is compressed. By means of a connecting-link the lower short arm of the hammer is connected to the rear end of the said rod, and by the motion of the said rod in the direction described the ham-

mer is raised and thrown back into its cocked position, in which position it is retained by the sear of the trigger engaging with the bent of the said hammer, in the usual way, so that on shutting down the barrels the hammer is left in its cocked position. When, by pressure on the trigger, the sear is released from the bent, the action of the compressed coiled spring urges the sliding rod toward the break-off, thereby causing the hammer to fall upon the striker and discharge the gun.

In the arrangement described the ordinary mainspring is dispensed with, the coiled spring described effecting the discharge of the gun. We do not, however, limit ourselves to this arrangement, as an ordinary mainspring may be employed, in which case the coiled spring described may be dispensed with; or the ordinary mainspring and a weak coiled spring may be employed; or the hammer actuated by an ordinary mainspring may not be directly connected with the sliding rod described, the said rod being jointed to a nearly vertical lever in front of the hammer, an anti-friction roller on the top of the said lever bearing against the breast or front of the hammer. On the lifting of the breech ends of the barrels, the sliding rod causes the said lever to push back the hammer into its cocked position; or the lever last described may be made to operate upon a striker having a sliding motion instead of upon a hammer; but we do not confine ourselves to any particular kind of lock mechanism, the essence of our invention consisting in making a pin or projection on the under side of the barrel give, on the raising of the breech ends of the barrels, a sliding motion to a rod, by which motion of the sliding rod the cocking of the gun is effected.

We will now describe, with reference to the accompanying drawings, the manner in which our invention may be performed.

Figures 1 and 2 represent longitudinal sections of the breech ends of a double-barrel drop-down gun containing cocking mechanism constructed according to our invention, Fig. 1 representing the parts in the positions which they respectively occupy after the gun has been discharged, and Fig. 2 the same after the barrels have been raised from the break-off

for reloading and the hammers cocked. Fig. 3 represents a portion of the under side of the barrels.

As the cocking mechanism for each of the barrels of the gun is of the same construction, we will only describe the mechanism situated on one side of the body for cocking the hammer of one of the barrels.

The same letters of reference indicate the same parts in Figs. 1, 2, and 3.

a are the barrels, turning on the joint *b* on the body, as usual. *c* is a sliding rod, situated and working in a recess in the side of the body *d*. Around the said rod *c* is a strong coiled spring, *e*, for urging the said rod when at liberty to move toward the break-off. The said spring *e* takes its abutment at one end against a collar at *f*, on the rear end of the rod *c*, and at the other end against a shoulder, *f*², in the body *d*. On the upper side of the said rod *c*, and near its front end, is a lug, *g*, of the form represented, the said lug extending upward to the under side of the barrel. On the under side of the barrel is a pin or projection, *h*, with an inclined face, for operating, in the manner hereinafter described, upon the lug *g* of the sliding rod *c*. *i* is the hammer of the gun, turning on the center *i*², the said hammer and the lock mechanism being carried by the lock-plate *r*, which is fixed to the side of the body; but the lock-plate *r* may be dispensed with, and the hammer and lock mechanism be carried by the body of the gun. The tail end of the said hammer *i* is connected by the link *l* to the rear end of the sliding rod *c*.

When the rear end of the barrel *a* is raised for opening the breech end after the discharge of the gun, the pin or projection *h* on the under side of the barrel performs a curvilinear motion around the joint *b*, and, by acting on the lug *g* on the sliding rod *c*, pushes the said lug before it, and consequently gives a sliding motion to the said rod toward the joint end *b* of the body, and compresses the coiled spring *e*. As the rod *c* moves in the direction described it operates, through the link *l*, upon the hammer *i*, and throws back the said hammer into its cocked position, in which position it is retained by the sear *p* of the trigger mechanism engaging with the bent in the said hammer, as illustrated in Fig. 2. The hammer is thereby cocked by the raising of the breech end of the barrel for loading, the said hammer, on the shutting down of the barrel, being left in its cocked position for discharge. When the trigger is pulled to discharge the gun, the sear *p* is released from its bent, and by the action of the compressed coiled spring *e* the sliding rod *c* is urged toward the break-off, thereby causing the hammer *i* to fall upon the striker *q* and discharge the gun, as illustrated in Fig. 1.

It will be understood that on the raising of the breech ends of the double-barrel gun represented, the sliding rods *c c* at the sides of the body operate simultaneously upon their re-

spective hammers, and raise the said hammers to full-cock for discharge, in the manner described with respect to one only of the said hammers.

Fig. 4 represents, in longitudinal section, a gun containing cocking mechanism constructed according to our invention, in which the hammer is actuated by an ordinary mainspring instead of by a coiled spring around the sliding rod.

In this arrangement the hammer and lock mechanism are carried by a lock-plate, *r*, as before described, the hammer *i* being actuated by the mainspring *s*. Instead of linking the tail end of the hammer to the sliding rod *c*, as before described, in this arrangement a nearly vertical lever, *t*, is situated in front of the hammer *i*. The end of the upper arm of the lever *t* carries an anti-friction roller, which bears against the breast or front of the hammer, as represented. The lower arm of the said lever *t* is jointed to the rear end of the sliding rod *c*. When the sliding rod *c* is pushed back toward the joint end of the gun, on the lifting of the barrels for loading, the said rod turns the lever *t* on its center, and causes its upper arm to act upon the hammer and raise it to full-cock.

In this arrangement the cocking mechanism is wholly detached from the hammer and lock mechanism.

Instead of a hammer, as represented in Fig. 4, a striker may be substituted therefor, and be actuated by the sliding rod *c* and lever *t*, on the lifting of the breech ends of the barrels for loading.

Fig. 5 represents a modification of our invention. In this modification the sliding rod *c*, instead of being moved by the lifting of the barrels toward the joint, as before described, is moved toward the break-off of the gun. This is effected by making the projection *u* on the under side of the barrel with an acting face inclined in the direction represented, the said inclined face of the projection *u* bearing against a roller on the front end of the sliding rod *c*. The back end of the sliding rod *c*, in the arrangement shown in Fig. 5, is linked to the lever *v* above the joint on which it turns, and the upper end of the said lever bears upon the breast of the hammer *i*. When the barrels *a* are lifted from the break-off for loading, the inclined projection *u* on the under side of the barrels forces the sliding rod *c* in the direction indicated by the arrow, and the said rod, acting through the lever *v*, pushes back and lifts the hammer *i* to full-cock.

Fig. 6 represents the cocking arrangement shown in Fig. 5 applied to the cocking of a striker. In this case the upper end of the lever *v* acts upon the arm *w* on the striker *x*, and forces back the said striker, the latter being retained in its withdrawn position by a sear, in the ordinary way. The other arrangements represented may also be arranged to actuate a striker.

Instead of forcing the sliding rod *c* in the

direction of the break-off by an inclined projection on the under side of the barrels, the same result may be obtained by making an inclined projection on the lump on the under side of the barrels act upon the said sliding rod when the barrels are lifted for charging. This modification is represented in Fig. 7, where the inclined projection on the lump which acts upon the sliding rod *c* to cock the hammer is marked *y*.

Having now described the nature of our invention, and the manner in which the same is to be performed, we wish it to be understood that we claim as our invention—

1. The combination, with the gun-stock, the single or double barrel, hinged at a proper point between the breech and muzzle, so as to drop down to expose the breech, and the hammer or exploding devices located in the stock, of independent locking mechanism to secure the breech of the barrel to the break-off, a projection or projections on the under side of the barrel, at a suitable point between the hinge and breech, and a sliding rod for

each barrel, arranged in one or more recesses in the gun-stock, substantially parallel with the length of the gun, in the manner described, so as to be made to slide by the action of the projection or projections on the barrel, to cock the hammer or hammers ready for firing in turning the barrel on its hinge to expose the breech for loading, substantially as set forth.

2. The herein-described cocking mechanism for drop-down guns, the same consisting of a projection on the under side of the gun-barrel, and a sliding rod located in a recess in the gun-stock, and provided with a lug at its forward end, adapted to be engaged by the projection on the under side of the barrel, and to be drawn forward to cock the hammer, or its equivalent, substantially as set forth.

WILLIAM MIDDLEDITCH SCOTT. [L. s.]
THOMAS BAKER. [L. s.]

Witnesses:

GEORGE SHAW,
RICHARD SKERRETT, •
Both of 37 Temple Street, Birmingham.