

G. A. FISCHER.
Stop-Cock.

No. 210,454.

Patented Dec. 3, 1878.

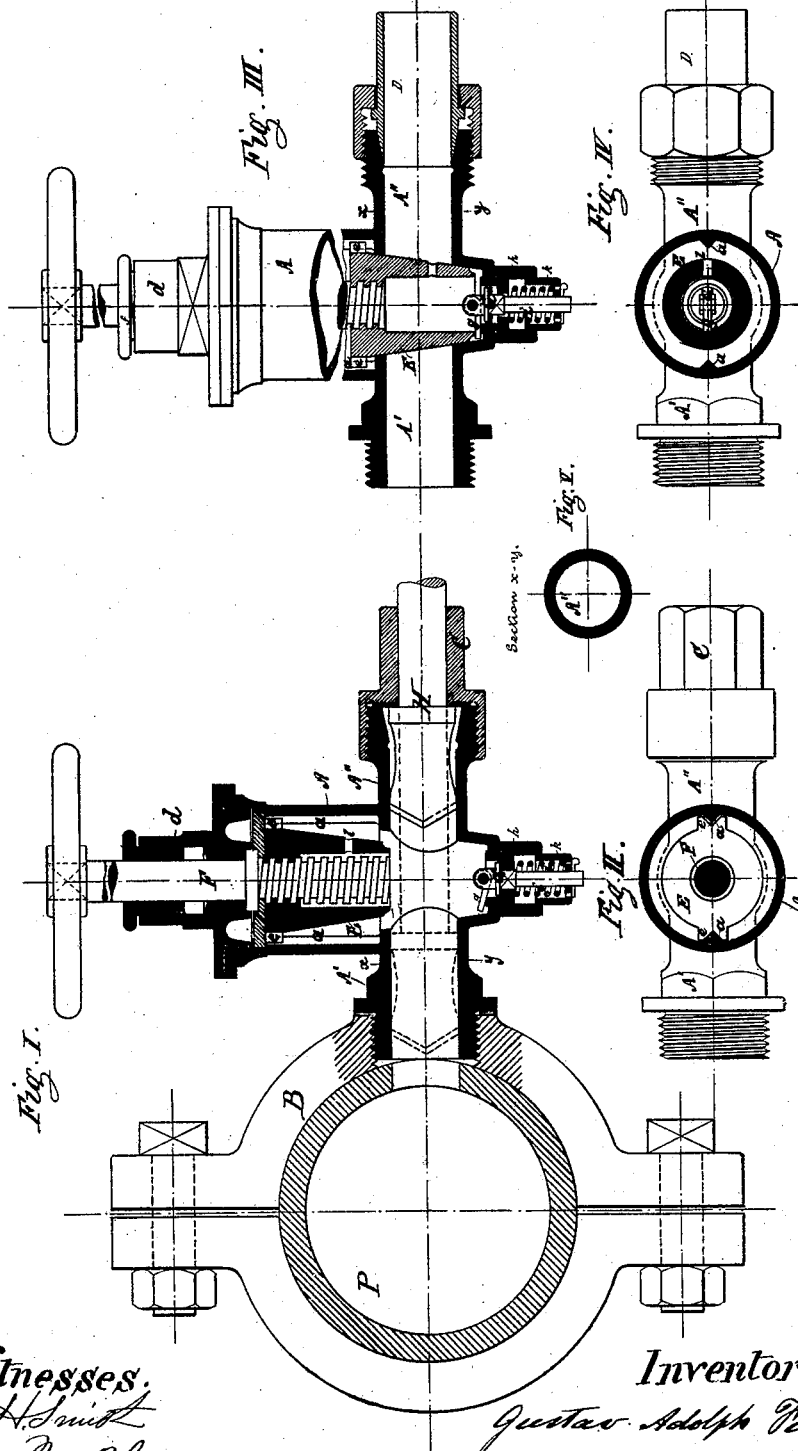

Witnesses.
Charles H. Smith
Abram Naublacon

Inventor.
Gustav Adolph Fischer
per Henry & Roder
Attorney

UNITED STATES PATENT OFFICE.

GUSTAV A. FISCHER, OF GORLITZ, PRUSSIA.

IMPROVEMENT IN STOP-COCKS.

Specification forming part of Letters Patent No. **210,454**, dated December 3, 1878; application filed June 5, 1878.

To all whom it may concern:

Be it known that I, GUSTAV ADOLPH FISCHER, of Gorlitz, Prussia, have invented a new and useful Improvement in Plug Stop-Cocks, of which the following is a specification:

In the accompanying drawing, Figure I represents a longitudinal section of a plug stop-cock embodying my invention. Fig. II is a horizontal section. Fig. III is a longitudinal section with the plug closed; Fig. IV, a horizontal section of the same, and Fig. V a section at line *x y*, Figs. I and III.

The nature of my invention consists in the construction of a plug stop-cock having perfectly-circular branches to fit and pass a suitable boring-tool through the same for the purpose of perforating a conducting-pipe to which this cock is to be attached; further, in the arrangement of the plug and in the arrangement of an automatical draining-valve.

A is the chamber of the cock, provided with the usual two branches A' and A'' for the connections. These branches are made perfectly cylindrical in their interior sections to allow the introduction and passing of a boring-tool, H, (see Fig. I,) through the same and the chamber A.

When the conducting-pipe P is to be tapped, a bridle, B, is attached at the desired place, into which the end branch, A', of the cock is screwed. The boring-tool H can then (as the branches A' and A'' are perfectly cylindrical, and after the plug E has been moved upward) be passed through these branches to perforate this conducting-pipe P. During this operation a muff, C, is fastened upon the branch A'' to guide the boring-tool H, and at the same time close this end of the cock. After the pipe P has been perforated or tapped, the boring-tool H is partly withdrawn, so that the plug E can be closed when the tool H is removed, preventing any waste or escape of gas or fluid except the small quantity contained in the branch A''.

E is the plug, provided with ears *ee* on its upper end, working on the guides *aa* on the chamber. This plug E is operated by the screw-spindle F to move upward or downward in and out of its seat in the lower part of the chamber. The upper part of the spindle passes through a suitable stuffing-box, *d*, in the cover of the chamber.

In the bottom of the chamber A a valve, G, is arranged, provided with a lever, *g*, and suitable spring *i*. When the plug E is opened this spring *i* will keep the valve G closed. By shutting the plug the end of the same comes in contact with the lever *g* and opens this valve G, as shown in Fig. III. The opening of this draining-valve G is only performed when the plug is closed, so as to occasion no loss of steam or water. In the plug E a small opening, *l*, is made in the side of the branch pipe A'' to allow the water in this lateral pipe to pass through the draining-valve.

This stop cock may also be used as an ordinary stop-cock in any part of a length of pipes by dispensing with the draining-valve G.

What I claim as my invention, and desire to secure by Letters Patent, is—

1. A circular valve-chamber, A, the interior circular surface of which forms the seat for the circular plug E, in combination with two branches, A' and A'', opposite each other and whose interior areas are perfectly circular in their sections, in the manner and for the purpose substantially as described.

2. In combination with a plug stop-valve, the draining-valve G, with lever *g* and spring *i*, arranged to operate in the manner and for the purpose specified.

GUSTAV ADOLPH FISCHER.

Witnesses:

FR. A. GERBER,
A. E. GEISSLER.