

A. C. KREIS.
Connector for Battery Carbons.

No. 210,460.

Patented Dec. 3, 1878.

Fig. 1

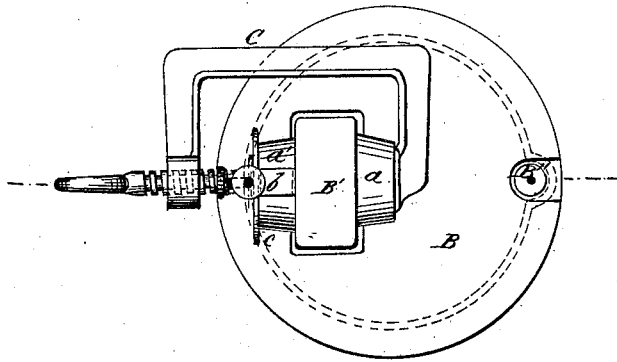

Fig. 5

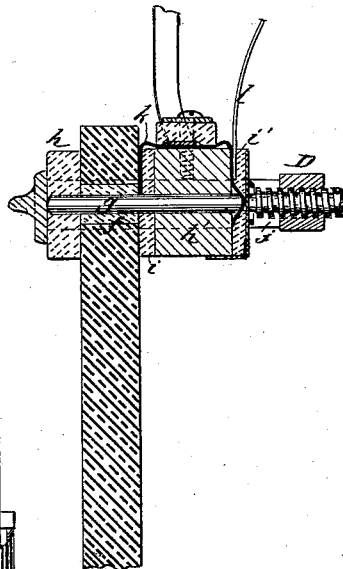
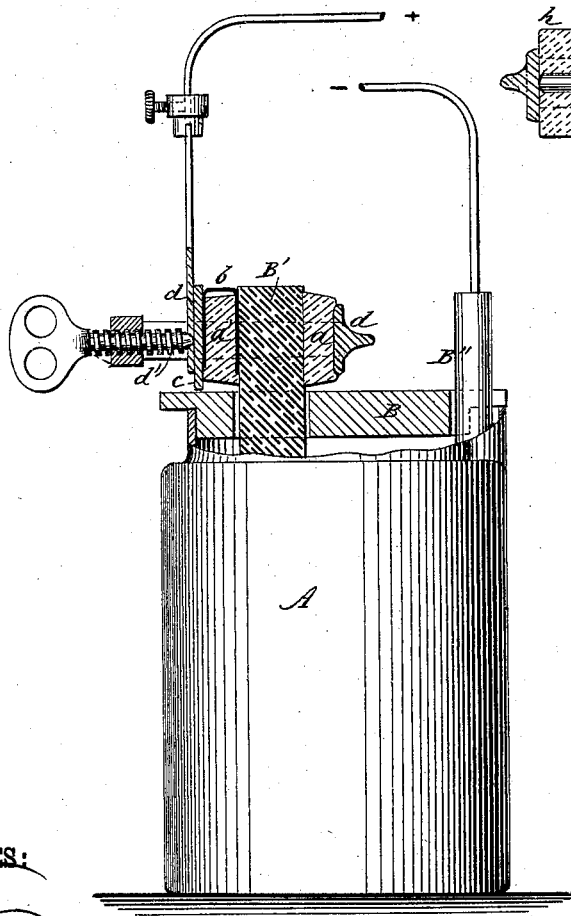

Fig. 2



WITNESSES:

C. Neveux
C. Sedgwick

INVENTOR:

A. C. Kreis

BY

Munn & Co

ATTORNEYS.

UNITED STATES PATENT OFFICE

ADAM C. KREIS, OF NEW YORK, N. Y.

IMPROVEMENT IN CONNECTORS FOR BATTERY-CARBONS.

Specification forming part of Letters Patent No. **210,460**, dated December 3, 1878; application filed October 26, 1878.

To all whom it may concern:

Be it known that I, ADAM C. KREIS, of the city, county, and State of New York, have invented a new and Improved Connector for Battery-Carbons, of which the following is a specification:

The object of this invention is to provide a connector for the carbons of batteries with the copper disks or strips that will prevent the rapid destruction of the metal attachments, which are subject to corrosion by the exciting-fluid in the batteries.

It consists in interposing between the said corrodible metal attachment a non-conducting substance, and then connecting the corrodible metal attachment with the carbon by means of platinum or other free conducting non-corrodible metal strips or wires passed around or over the said interposed substance.

In the accompanying drawing, Figure 1 is a top view of a battery provided with my improvements. Fig. 2 is a side elevation of the same with the connector in section, and Fig. 3 is a sectional view of a modification of my improvement.

Similar letters of reference indicate corresponding parts.

Referring to the drawing, A represents the glass jar of the battery, provided with a cap, B, through an opening in which is placed the carbon slab B', and opposite this the zinc rod B'' is placed in another opening in the cap.

My improved connector consists of the block *a*, of a non-conducting non-corrodible substance, placed on one side of the carbon above the cap, and on the opposite side is another piece, *a'*. Around or over the block *a'* is placed a platinum strip, *b*, one end between the block *a'* and the carbon, the other end on the opposite side, and against this end is placed the copper disk *c*, with a copper strip or wire, *d*, rising from it. A screw-clamp, C, is now applied, one end, *d*, bearing against the block *a*, while the screw *d'* bears against the copper disk *c*, or the strip attached to it, and by this clamp the parts are firmly secured together, as shown in the drawing.

By this arrangement it will be seen that the corrodible-metal conducting-disk *c* and the clamp are entirely isolated from the carbon by

the interposed blocks *a a'*, and thus the exciting-fluid carried up by the carbon does not reach the parts liable to corrosion; hence the metal attachments are saved from the rapid deterioration and destruction to which they are ordinarily liable.

In Fig. 3 a modification of my improvement is shown. Here a hole is made in the upper part of the carbon, and a sleeve, *f*, of non-conducting material, is inserted. Through this is thrust a bone pin, *g*. On one end thereof is placed a non-conducting non-corrodible block, *h*, while on the opposite end is placed a hard-rubber or wooden block, *h'*. Between block *h'* and the carbon is placed a disk, *i*, of some non-conducting material—as cork, for instance—while at the opposite end of the block is placed, in any suitable manner, a similar disk, *i'*, to the outside whereof is fixed a metal plate, *j*, for the bearing-point of the screw of the clamp. Over or around the block *h'* is placed a platinum strip, *k*, one end of which is inserted between the disk *i* and the carbon, while the opposite end is carried down on the other side and secured in contact with the copper strip *l*, between the disk *i'* and the block. Thus arranged, the parts are all secured together by the screw-clamp D, in the manner clearly shown in Fig. 3.

Instead, however, of placing the outer end of the platinum strip in contact with the copper strip *l*, the latter may be secured in contact therewith on top of block *h'*, as shown.

There is a special advantage obtained by using this last-mentioned arrangement, as, the copper strip being fastened down by the screw, no clamp is necessary, the pin *g* holding the parts on the carbon sufficiently tight to allow all metal clamps to be dispensed with. Thus the cost of the battery is lessened, and one of the parts soonest destroyed removed.

The end of the platinum strip may be embedded in the carbon, or held between pieces of that material, or fastened in any way without departing from my invention.

From this description it will be readily apparent that the corrodible-metal attachments are completely cut off from contact with the carbon, and are thus prevented from corrosion, to which they are ordinarily subject when

placed in immediate contact therewith, as the carbon, being very porous, raises the exciting-fluid constantly.

The material used for isolating the corrodible-metal attachments of the battery from the carbon may be cork or rubber, or any other non-corrodible and non-conducting material. Cork is preferable on account of its practical indestructibility; but I do not confine myself to this material. So, too, the connection between the carbon and the copper conducting strips and disks, which is here referred to as platinum, may be of gold, or any other metal combining good conducting power with resistance to corrosion.

Having thus described my invention, I

claim as new and desire to secure by Letters Patent—

As an improvement in connectors for battery-carbons, the non-corrodible non-conducting blocks *a a'*, interposed between the battery-carbon *B'* and the corrodible-metal attachments of the battery, in combination with carbon *B'*, copper conducting-disk *c*, screw-clamp *C*, and connecting-strip *b*, of good conducting non-corrodible metal, substantially as described.

ADAM C. KREIS.

Witnesses:

J. H. SCARBOROUGH,
C. SEDGWICK.