

J. C. SENDERLING.
Pulverizing-Barrel.

No. 210,471.

Patented Dec. 3, 1878.

Fig. 1.

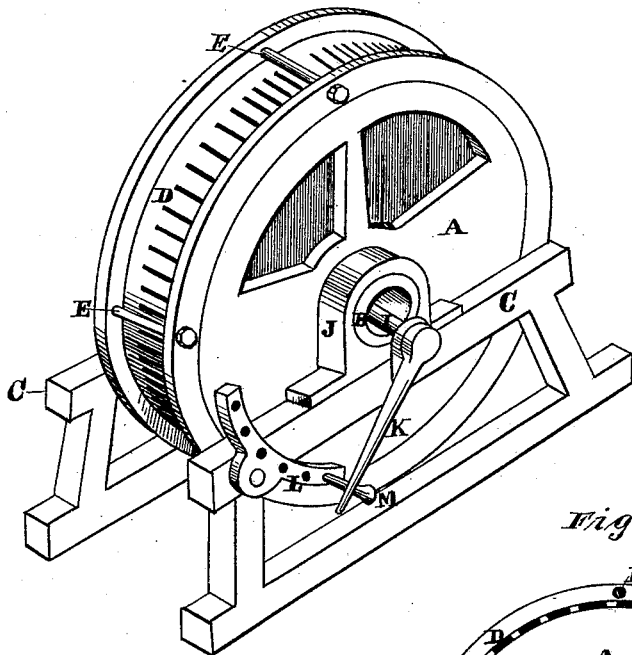

Fig. 2.

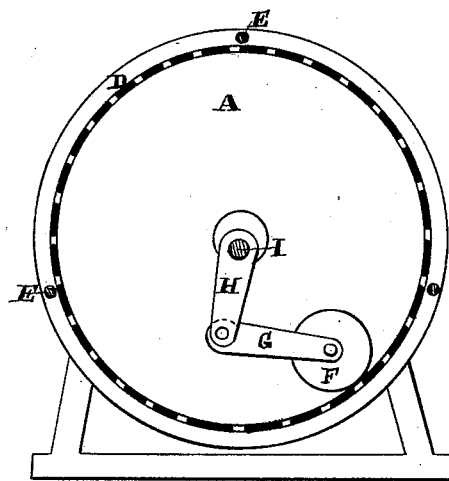
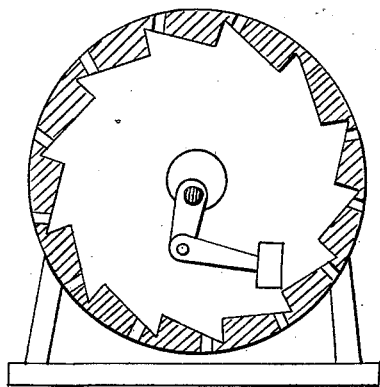

Fig. 3.



Witnesses

Geo. H. Strong
Frank W. Burkes

Inventor

John C. Senderling
By Dewey & Co.
attys

UNITED STATES PATENT OFFICE.

JOHN C. SENDERLING, OF SAN FRANCISCO, CALIFORNIA.

IMPROVEMENT IN PULVERIZING-BARRELS.

Specification forming part of Letters Patent No. 210,471, dated December 3, 1878; application filed September 2, 1878.

To all whom it may concern:

Be it known that I, JOHN C. SENDERLING, of the city and county of San Francisco, and State of California, have invented an Improvement in Crushing and Pulverizing Barrels; and I do hereby declare the following to be a full, clear, and exact description thereof, reference being had to the accompanying drawings.

My invention relates to certain improvements in crushing and pulverizing barrels, or that class of apparatus in which balls, rollers, shoes, hammers, &c., are employed to crush and pulverize rock within a rotating cylinder or barrel.

It consists in the employment of a non-rotating, stationary, or adjustable shaft passing through the hollow trunnions of the barrel, and supporting a roller, shoe, or hammer from its inner end or arm. The said roller, shoe, or hammer may thus be held at a certain point, and as the ore or rock to be crushed is fed into the barrel it passes between the roller, shoe, or hammer and the inner periphery of the cylinder or barrel. The pulverized ore will escape through perforations or slits in the dies and, from thence through the inclosing-screens, while any particles not crushed sufficiently fine will remain in the cylinder or barrel.

An adjusting arm and rack may be connected with the shaft, so that the pulverizer may be set at any point desirable within the barrel.

Referring to the accompanying drawings for a more complete explanation of my invention, Figure 1 is a perspective view of my machine. Fig. 2 is a vertical section. Fig. 3 shows a modification.

In the construction of barrels for crushing and pulverizing rock it has been usual to employ balls or rollers, which were free to move within the barrel as it rotated. As a consequence the tendency of the balls was to gravitate toward the lower part of the barrel; and when balls of different weights were used the heaviest lay the lowest, while the smaller ones arranged themselves up the side of the barrel according to their weight. The ore when fed into the barrel is also carried up the sides of the barrel, and as a consequence it is never subjected to the continued action of the heavy

balls. In order to remedy this, and make my crushing apparatus most effective, I mount my crushing-roller upon an arm which is supported from the center, so that the roller may be maintained at a point where it will be most effective in crushing the ore.

A is the barrel or cylinder, which is mounted by means of trunnions B upon a suitable framework, C. D are the dies which form the rim or periphery of the drum or barrel, and they are secured between the sides A by being suitably fitted and held by bolts and nuts E, which draw the sides together. The dies are perforated or made with fine slots, through which the ore will pass when fine enough, and an outer fine screen may be employed. When this is done any ore which is not crushed fine enough to pass the outer screen is returned by a side passage to the interior of the barrel.

The crusher consists, in the present case, of a heavy roller, F, which is mounted upon journals supported by the arm G. This arm is hinged or jointed to the arm H, and the arm H is keyed or otherwise secured to the shaft I. The shaft I extends through the hollow trunnions B, and is supported in exterior boxes J, as shown. This shaft may be adjusted so as to hold the roller permanently in one place; but I prefer to make it adjustable, and this is done by means of the arm K, secured to one end of the shaft, and a curved rack, L, with a pin, M, or other equivalent device, by which the arm K is held at any desired point.

It will be seen that by means of this device the crushing-roller may be held at a point where the ore tends to accumulate by the rotation of the barrel. It can thus be made of any desired weight, and the barrel may be correspondingly shortened. The ore is thus subjected to the heaviest weight, and the rolling motion upon the interior of the cylinder or barrel subjects it to the most thorough crushing action with the least expenditure of power. The shaft I passing through the trunnions interposes no obstacle to the ore being fed in at this point, and it is perfectly independent of the barrel.

In some cases it may be found desirable to employ a shoe in the place of the crushing-roller, and this is then supported at the end of the arm G in place of the roller.

When a hammer is to be employed the interior of the dies will be formed into a series of angular steps, as shown in Fig. 3, and the rotation of the barrel causes the hammer to move up the inclines successively and fall upon the steps, where the ore has accumulated; but I prefer the roller above these methods, as being the most efficient.

It will be manifest that the arm G, which supports the roller, might be keyed directly to the shaft I, and the journals of the roller F supported in slots, which would allow the roller to adjust itself to irregularities, and springs might be employed to increase the pressure of the roller; but such modifications are mechanical equivalents, which will suggest themselves readily.

The whole apparatus is simple, economical, and effective.

Having thus described my invention, what I claim, and desire to secure by Letters Patent, is—

1. The crushing-roller F, journaled in the arm G, and having frictional contact with the barrel, said arm being supported by the inde-

pendent shaft I, and adjusted by the arm K, with its holding-rack, substantially as and for the purpose herein described.

2. The roller F, journaled in the hinged arms G H, which allow the roller to rise and fall and adjust itself to irregularities, said arm or arms being keyed to the independent shaft I, passing through the hollow trunnions and held at any point, substantially as herein described.

3. The independent shaft I, passing through the trunnions B of the rotating cylinder or barrel, and supported upon exterior bearings, so as to be adjustable independent of any movement of the barrel, said shaft supporting and governing the position of the roller, shoe, or hammer F, substantially as herein described.

In witness whereof I have hereunto set my hand.

J. C. SENDERLING.

Witnesses:

GEO. H. STRONG,
FRANK A. BROOKS.