

J. W. PYNE.  
Middlings-Separators.

No. 210,558.

Patented Dec. 3, 1878.

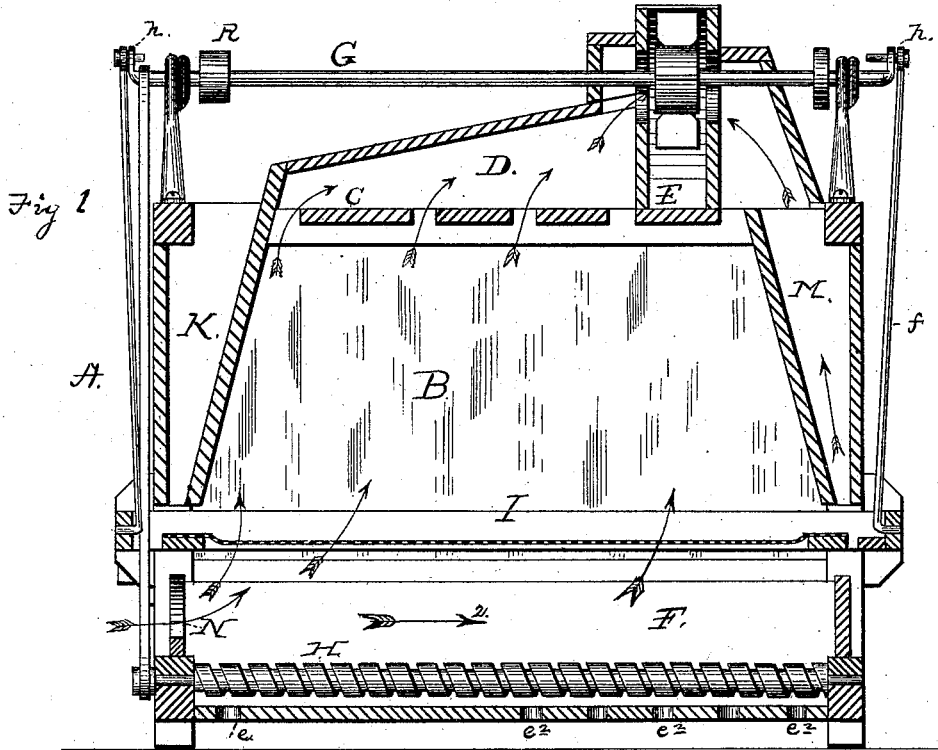

Fig. 2.

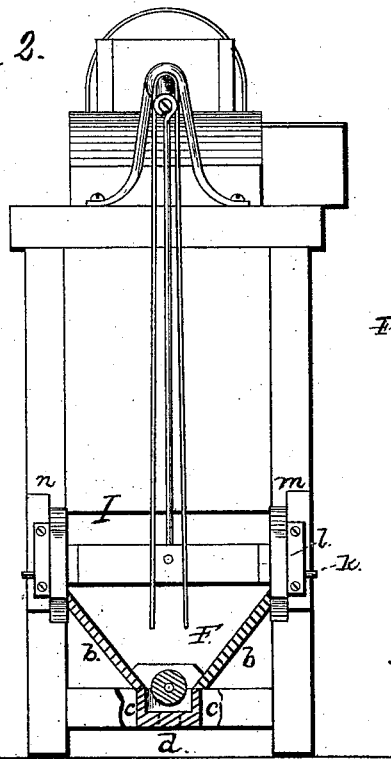
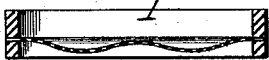
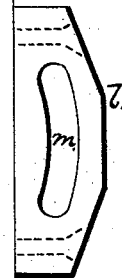

Fig. 3.



WITNESSES  
Nat. E. Oliphant.  
J. Tyler Powell

Fig. 4.



INVENTOR  
John W. Pyne  
by  
Stephens & Kane  
Attys.

# UNITED STATES PATENT OFFICE.

JOHN WALTER PYNE, OF LOUISVILLE, KENTUCKY.

## IMPROVEMENT IN MIDLINGS-SEPARATORS.

Specification forming part of Letters Patent No. **210,558**, dated December 3, 1878; application filed October 24, 1878.

*To all whom it may concern:*

Be it known that I, JOHN WALTER PYNE, of Louisville, in the county of Jefferson and State of Kentucky, have invented a new and valuable Improvement in Middlings-Purifiers; and I do hereby declare that the following is a full, clear, and exact description of the construction and operation of the same, reference being had to the annexed drawings, making a part of this specification, and to the letters and figures of reference marked thereon.

Figure 1 of the drawings is a representation of a vertical sectional view of my machine. Fig. 2 is an end view, partly broken away, to show the conveyer-chamber. Fig. 3 is a transverse sectional view of the riddle, showing the bolt-cloth with the wave-motion. Fig. 4 is a side view of the box, showing fully the bracket formed with the curved slot, which produces the longitudinal movement of the riddle by means of the pin *k*, as hereinafter explained.

This invention has relation to certain improvements in middlings-purifiers, as will be hereinafter more fully set forth, and pointed out in the claims.

The object of the invention is to furnish a cheap apparatus for purifying middlings and similar materials, which shall be simple in construction and effective in operation, doing its work as well as, if not better and more quickly, than ordinary machines of this class.

In the annexed drawings, forming a part of this specification, the letter A represents the casing, preferably with glass sides B, so that the miller can easily inspect the interior working of the machine, and see that no waste is produced.

The top portion, C, of the casing is provided with a series of openings and regulating-valves leading into a passage or chamber, D, above said top C, and in one end of which is formed a fan-case, E, with a suction-fan, E', arranged on the main shaft G. By the action of the latter, bran, light specks, dust, and other light impurities are withdrawn from the flour and middlings and blown into a dust room or receiver.

The lower or bottom part, F, is constructed in the shape of a trough formed by the inclined boards *b*, vertical boards *c*, and bottom

board *d*, substantially as shown in Fig. 2 of the drawings.

The bottom board, *d*, is provided with a series of openings, *e*, through which the purified middlings are discharged. In this chamber F is arranged an endless screw or conveyer, H, for conducting the purified material to the discharge-openings.

In the middle portion of the machine is placed the sieve or shaker frame I, which is made of such a size as to fit into and move easily in the chamber or cavity of the machine. The upper surface of the sieve-frame is covered with bolt-cloth of any degree of fineness, which hangs loosely, so that in the rapid up-and-down movements of the sieve-frame a snap or wave motion (similar to the shaking motion given a carpet to remove dust) will be given to the bolt-cloth, which will keep the chaff and middlings well distributed over the bolt-cloth, so that all the cloth is doing its duty at the same time. By this means the cloth is kept clean and the meshes open without the aid of brushes, knockers, or blast-pipes, to enable the fine flour to pass readily through the cloth to the conveyer-chamber.

A suitable hopper (not shown) is placed on top of the machine, to receive the material from the grinding-stones, and from which it is conducted through the chute or passage K onto the head of the sieve, receiving a compound motion.

The sieve or riddle frame is suspended at the ends by means of connecting rods or pitmen *f*, arranged on opposite ends of the machine, the upper ends of which are journaled to cranks *h*, attached to or forming a part of the main shaft, which is suitably supported by brackets upon the frame, so that the riddle-frame, carrying the bolt-cloth, retains a horizontal, or nearly horizontal, position.

The upper end of the riddle-frame is provided with side journals or pins *k*, working in boxes *l*, attached to the ends of the machine, the boxes being provided with curved slots *m*, which produces a slight horizontal motion simultaneously with the perpendicular motion; also, by adjusting the boxes *l*, the inclination of the sieve can be varied to increase or decrease the feed of the middlings through the

machine. These boxes, as well as the strips *n*, act as guides, and prevent any twisting motion of the riddle-frame in its rapid movements.

When the vertical reciprocating motion is communicated to the riddle-frame, carrying the bolt-cloth, a rapid up-and-down movement, at the rate of about six hundred vibrations per minute, is produced, such as to cause the middlings upon the bolt-cloth to be thrown upward from the bolt-cloth. Additional motion (lateral) is imparted to it, so as to cause the middlings to travel along the same. The effect of this compound motion to the bolt-cloth is to submit the middlings more thoroughly to the action of the suction-draft while being in suspension or thrown upward from the bolt-cloth; leaves the lighter and impure parts of the material on top, so that it may be more readily removed by the suction of the exhaust-fan; and also, when returning to the bolt-cloth, an impetus is given to the middlings, whereby the finer portions more readily fall through the bolt-cloth, and the coarse stuff is caused to pass onward and finally over the tail end of the bolt-cloth to a receptacle to receive it. The middlings and fine flour passing through the bolt-cloth are conducted to a conveyer-chamber below.

The cranks of the main shaft should move together, so that the riddle-frame is raised and lowered bodily.

The conveyer is driven from the main shaft by means of a belt passing over pulleys suitably arranged on the shaft and at the end of the conveyer-shaft. The air is admitted from the outside through an opening, *N*, in the casing below the riddle-frame, as shown by the arrow in Fig. 1 of the drawings. This admitted air passes upward through the sieve by suction, carrying therewith the light material, separated from the middlings and flour, into the fan-case, as shown by the arrows.

At the tail end of the machine is arranged a vertical oblong tube or passage, *M*, communicating with the fan-case, to carry off the light bran, &c., from that end of the machine, which might obstruct the passage at certain times.

It will be observed that I take the air entirely from the head end of the machine below

the riddle-frame, thereby producing heavy currents of air to the tail end, so that if any specks or light impurities should pass through the bolt-cloth they are carried to the tail end of the machine in the conveyer-chamber by the arrow 2, and cut off from the good stuff by means of the openings *e*<sup>2</sup> in the bottom board. By means of the air entering at this point I get a double separation, and produce better results than in machines heretofore made.

Power to drive the machine is communicated through a belt to the pulley *R* from the moving power of the mill.

What I claim as my invention, and desire to secure by Letters Patent, is—

1. A sieve or riddle of a middlings-purifier, the bolting material of which hangs loosely, so that in the vertically-reciprocating motion of the riddle, caused by mechanism, a wave-motion is given to its bolting-surface, substantially as set forth.

2. A sieve or riddle with its bolting material hanging loosely, having a compound motion—to wit, a rapid vertical and longitudinal movement—and a wave-motion to the bolting material, caused by mechanism, substantially as described.

3. The combination, substantially as described, of the casing having a series of openings at the bottom for the discharge of the purified material and an opening at the head end of the casing for the admission of air into the machine, a vertically-reciprocating riddle, and a suction-fan.

4. The combination, with a vertically-moving riddle-frame having side journals, of the adjustable boxes having curved slots for communicating a longitudinal motion to said frame.

5. The combination, in a middlings-purifier, of the main shaft, having a suction-fan, pulleys, and a crank at each end of the shaft, the pitmen, the riddle-frame, and mechanism for operating the conveyer, substantially as set forth.

In testimony whereof I have hereunto subscribed my name.

JOHN WALTER PYNE.

Witnesses:

M. C. TULLY,  
GEO. M. PAGE.