

E. ARMSTRONG.  
Bee-Hive.

No. 210,592.

Patented Dec. 10, 1878.

FIG. 1.

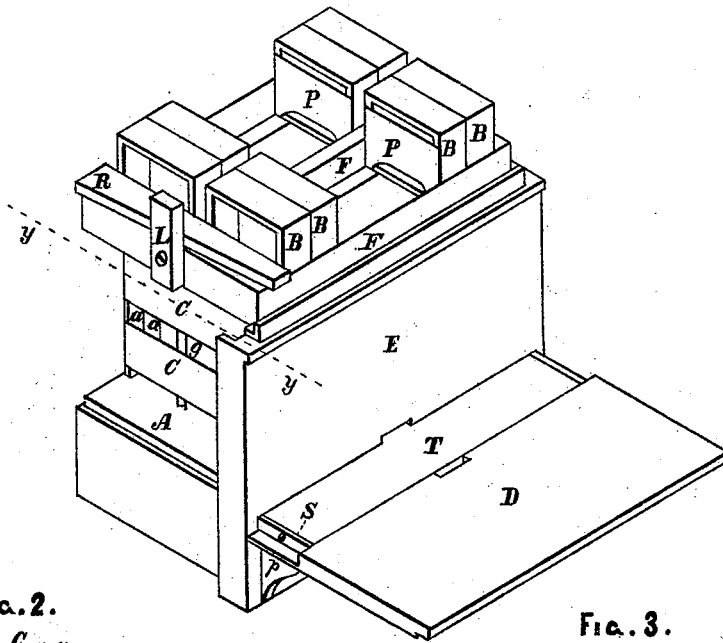

FIG. 2.

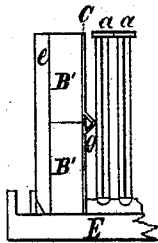
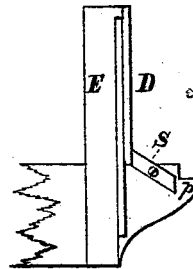

FIG. 3.



WITNESSES :

*E. G. Wilbur*  
*L. A. Wilbur*

INVENTOR :

*Elvin Armstrong*  
*by F. S. Davenport, Atty.*

E. ARMSTRONG.  
Bee-Hive.

No. 210,592.

Patented Dec. 10, 1878.

FIG. 4.

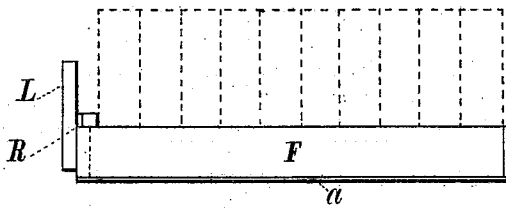

FIG. 5.

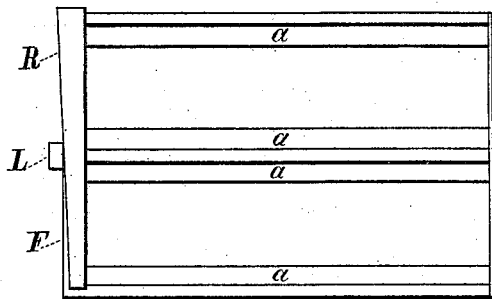
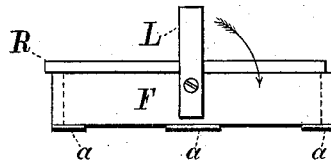

FIG. 6.



WITNESSES:

*W. Ford*  
*Mans R. Locke,*

INVENTOR:

*Elwin Armstrong.*  
*per J. S. Davenport, Atty.*

# UNITED STATES PATENT OFFICE.

ELVIN ARMSTRONG, OF JERSEYVILLE, ILLINOIS.

## IMPROVEMENT IN BEE-HIVES.

Specification forming part of Letters Patent No. **210,592**, dated December 10, 1878; application filed September 5, 1878.

*To all whom it may concern:*

Be it known that I, ELVIN ARMSTRONG, of Jerseyville, in the county of Jersey and State of Illinois, have invented a new and Improved Bee-Hive; and I do hereby declare that the following is a full and exact description of the same, reference being had to the accompanying drawings, and to the letters of reference marked thereon.

The invention herein described relates to bee-hives; and consists, as hereinafter fully described, of certain improvements on my patents of October 8, 1874, and January 22, 1876.

The improvements referred to include a novel manner of clamping together the honey-boxes, whereby the latter are held more securely and are more readily unclamped than by the means usually employed; also, an improved metallic independent separator for insertion between the honey-boxes; and, further, a novel separator to divide the brood-chamber from the surplus-honey boxes; and, still further, the adaptation of the alighting-platform to the front of the hive in such manner as to admit of its being turned up to the front wall of the hive for protection against cold in winter.

In the accompanying drawings, in which similar letters of reference indicate like parts, Figure 1 is a perspective view of the hive, the outer casing, surplus-honey boxes, and division-boards removed, exhibiting the features of improvement herein referred to. Fig. 2 is a plan view of the front end of the hive, taken in the line *y y*, Fig. 1. Fig. 3 is an end elevation of the front part of the hive, showing the alighting-platform turned up. Fig. 4 is a side elevation of the honey-rack detached from the hive, and shown upon a larger scale, in which the honey-boxes are exhibited in dotted lines in the position they occupy when secured by the clamping device above referred to. Fig. 5 is a plan view of the honey-rack and clamping device. Fig. 6 is an end elevation of the honey-rack, in which the movement of the clamping-button, when releasing the honey-boxes, is indicated by the arrow.

In Fig. 1, F represents the honey-box rack; B B, the honey-boxes, the central ones being removed in order to exhibit the separators P, which rest upon the bottom plates of the rack F, and are formed, as shown in the drawing,

so as to leave an opening at top and bottom of the honey-boxes for the admission and exit of the bees.

When the rack F is filled with honey-boxes, and a separator placed between each pair, the taper slat R is laid across the end of them, resting on the end of the rack F, to which is pivoted a button, L, which, when inoperative, lies horizontally. Matters being thus, and the taper slat R being of such breadth as to slightly overhang the end of the rack at its central part, or that part where the button L is pivoted, the said button is turned toward the vertical position, by which operation it is made to impinge upon the edge of the overhanging taper slat, which in turn presses directly on the end of each row of honey-boxes and holds them securely in position, without shock or jar, or anything of the kind likely to disturb the bees. The reverse operation liberates the boxes for examination.

It may here be observed that any contraction or expansion of the honey-boxes due to atmospheric changes can by this contrivance be easily made good by simply moving the slat R backward or forward in the direction of its length.

In regard to the separators P, it may be noted that those heretofore in use consist of long rectangular pieces of tin, adapted to reach across two or more rows of boxes; consequently while examining one row of boxes, the other rows are unavoidably disturbed. By means, however, of the independent separators here shown, this objection is removed, since the tilting of the boxes and removal of the separators in one row does not in any way disturb the boxes or separators in the other.

C represents the separator for insertion between the brood-chamber and surplus-honey boxes B'. (Shown in plan view, Fig. 2.) This separator consists, as shown in Fig. 1, of two rectangular plates, C C, supported one above the other upon a vertical bar, *g*, of triangular form, such distance apart as to lie across the face of each row of boxes, leaving an opening at top and bottom for the bees.

The cross-sectional form of the supporting-bar *g* is preferably triangular, for the reason that it impinges upon a smaller portion of the sides of the brood-chamber sections than if

flat, and consequently lessens the danger of crushing the bees when working the hive.

D, Fig. 1, represents the removable alighting-platform, supported in front of the permanent platform T by the forward-projecting ends of the brackets *p*, the cleats on the ends of the platform being made sufficiently long to pass under the buttons S, and thus support it, as shown in the drawing. In order to give additional protection to the bees in winter, this platform is turned up against the front wall, E, of the hive, and secured in position by turning

the ends of the buttons S against it, as shown in Fig. 3.

What I claim as my invention is—

In connection with the honey-rack F, the combination of the taper slat R and button L, substantially as and for the purpose set forth.

This specification signed and witnessed this 29th day of August, 1878.

ELVIN ARMSTRONG.

Witnesses:

C. C. CUMMINGS,

MURRAY B. TRABUE.