

J. BRIGGS.  
Piano-Stool.

No. 210,593.

Patented Dec. 10, 1878.

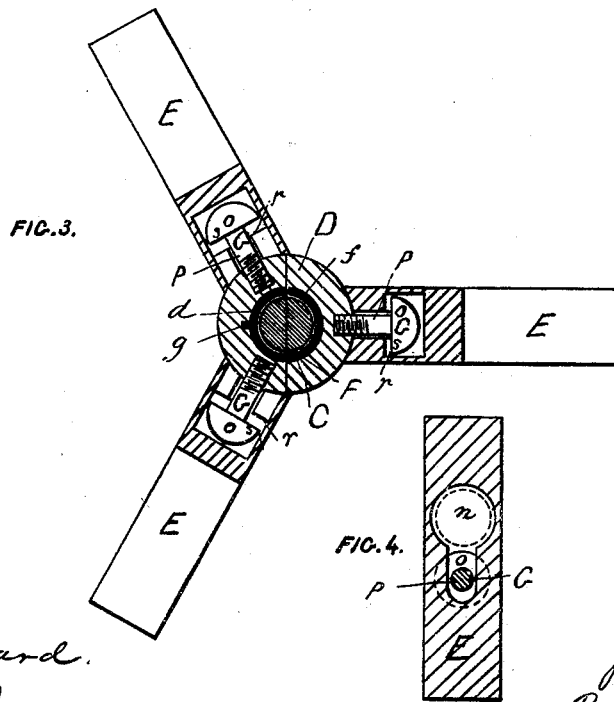
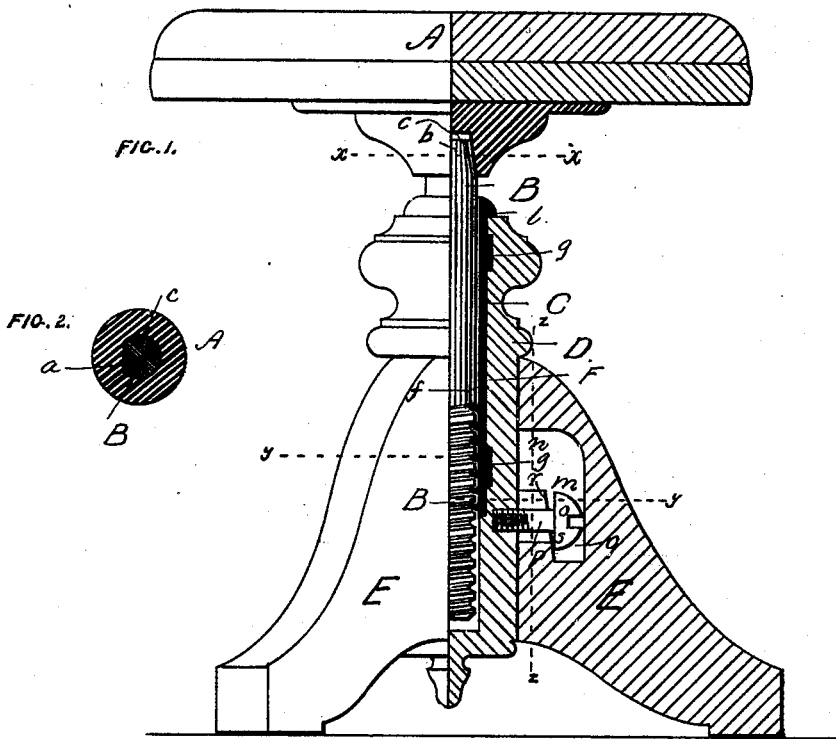

WITNESSES.

Chas. E. Hubbard.  
Geo. H. Carl.

INVENTOR.

J. Briggs.  
Per Brown & Co  
Attorneys.

# UNITED STATES PATENT OFFICE.

JOSHUA BRIGGS, OF PETERBOROUGH, NEW HAMPSHIRE.

## IMPROVEMENT IN PIANO-STOOLS.<sup>1</sup>

Specification forming part of Letters Patent No. **210,593**, dated December 10, 1878; application filed April 12, 1878.

*To all whom it may concern:*

Be it known that I, JOSHUA BRIGGS, of Peterborough, county of Hillsborough, and State of New Hampshire, have invented certain new and useful Improvements in Piano-Stools, of which the following is a full, clear, and exact description.

The object of my invention is to furnish an improved construction and combination of the parts involved in the raising and lowering of the seat of a piano-stool; and it consists in the combination, with the stool-standard, of an inserted screw-socket composed of two longitudinal sections, one of which is provided with a feather or feathers to prevent its turning, and a screw-threaded shaft attached to the bottom of the seat and engaging in the said socket, as will be hereinafter more particularly set forth.

Figure 1 is, in part, a central vertical section and a side elevation; Figs. 2 and 3, horizontal sections on lines *x x* and *y y*, respectively, Fig. 1.

In the drawings, A represents a piano-stool seat, having a screw-shaft, B, which works through a screw-nut, C, of the body or stand D, supported by three legs, E E E.

The screw-shaft B (which is preferably made of wrought-iron) is tapered, and has on one side, *a*, at its end *b*, a portion squared, and by this end it is driven into a wedge and squared socket, *c*, said socket being made of cast-iron, and cast in this shape to receive the head of the screw of the stool-seat A, which secures the two together, and prevents the one turning on the other as the screw is working in the screw-nut C, while at the same time obviously said two parts can be readily separated, when desired. This mode of attaching the seat to the screw I have found quite effective; but it forms no part of my invention, being in substance well known.

The screw-nut C is divided into two parts, *d* and *f*, along its length, which parts are cast with the threads on the inside, each having its proper proportion of the whole necessary to the proper working of the stool or elevating-screw B therein; and each part has one or more external ribs, *g*, which, when the nut is driven into the screw-shaft B, make for themselves grooves or beds in the wood along the inner surface of the socket F, which holds the nut. The ribs *g* hold the two parts of the nut from turning, and as the nut is in two pieces it can be the better driven into

position within the body D, and the shouldered end *l* of the nut limits the distance to which the nut can enter the socket.

Each leg is held in place by a headed pin, G, preferably a screw-pin, of the body D, over which fits a slot, *m*, of the leg, which slot is enlarged at *n* to receive the head *o* of the pin G, and below such enlargement narrowed in width to the size of the shank *p* of the pin; and inside of such enlargement and narrowed part of the slot the leg is recessed to receive the head of the pin G, and this recess, at the narrow part *q* of the slot, downwardly beveled along its face *r*, which bears against the shoulder *s* of the head of the pin G, all as shown more particularly in Fig. 3.

This attachment of the legs to the body obviously enables the legs to be readily separated from the body, and, when attached, the greater the weight upon the stool the tighter the legs are bound to the body.

A screw-pin, G, is preferable, as before stated, for the reason that it can be turned in or out to adjust it more perfectly to its work within the slot *m* of the leg E.

A piano-stool constructed as above described obviously possesses all the necessary rigidity or firmness of parts, while at the same time it is readily separated into its several parts for being compactly packed.

In lieu of squaring a portion of the tapered end of the screw-shaft B, as herein described, such end may be made of other shapes—as, for instance, concave, or convex, or ribbed, the socket *c* being correspondingly shaped to receive the same; and the herein-described mode of attaching the legs to the body of the stool is obviously applicable to other articles of furniture, such as bedsteads, tables, &c.

Fig. 4 is a vertical section of one of the legs E, on line *z z*, Fig. 1.

Having thus described my invention, what I claim, and desire to secure by Letters Patent, is—

The combination, with the standard D of a piano-stool and the screw-threaded socket C, composed of the parts *f* and *d*, the latter provided with feathers *g g*, of the screw-threaded seat-shaft B, substantially as described.

JOSHUA BRIGGS.

Witnesses:

EZRA M. SMITH,  
GEORGE STRATTON,