

F. A. HUNTINGTON.
Ore-Washer.

No. 210,609.

Patented Dec. 10, 1878.

Fig 1

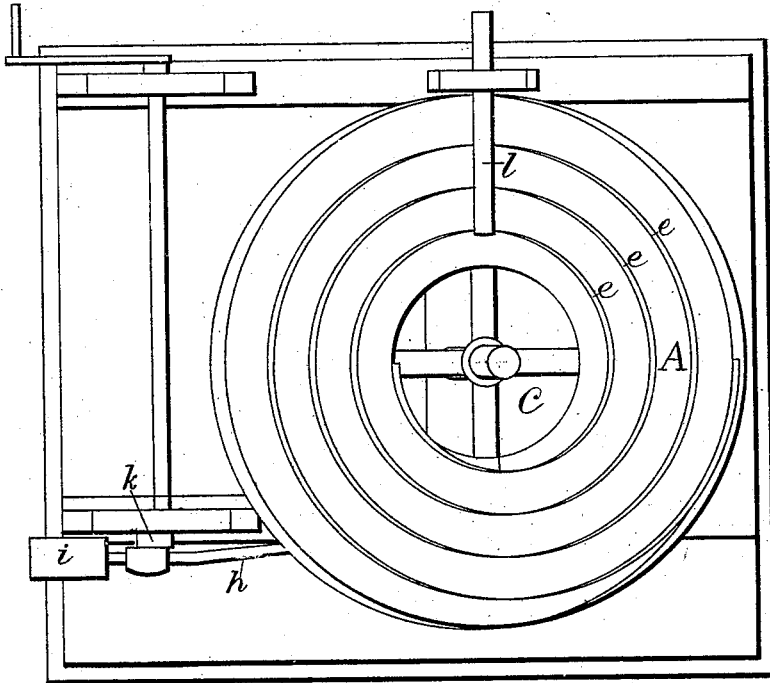
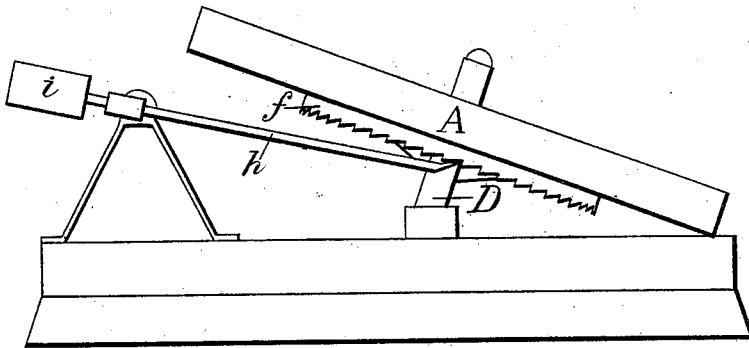

Fig 2



Witnesses

D. B. Lawler.
H. M. Chace

Inventor

Frank A. Huntington
per J. L. Boone
Attorney

UNITED STATES PATENT OFFICE.

FRANK A. HUNTINGTON, OF SAN FRANCISCO, CALIFORNIA.

IMPROVEMENT IN ORE-WASHERS.

Specification forming part of Letters Patent No. **210,609**, dated December 10, 1878; application filed October 16, 1878.

To all whom it may concern:

Be it known that I, FRANK A. HUNTINGTON, of the city and county of San Francisco, in the State of California, have invented an Improved Concentrator; and I do hereby declare that the following is a full, clear, and exact description thereof, reference being had to the accompanying drawings.

My invention has reference to an improved concentrator for separating the light and worthless portions of ore-pulp from the heavy and more valuable portions; and it consists of the arrangement and devices hereinafter specified.

Referring to the accompanying drawings, in which Figure 1 is a plan view and Fig. 2 is a side view, let A represent a flat circular disk, which is provided with a hole or opening, C, at its center. This disk I mount at an angle upon a spindle or shaft, D, so that it will rotate in a fixed plane, the inclination of which will depend upon the character of the material to be separated. On the upper side of this disk I secure a coiled flange, *e*, which commences at the edge of the central opening, and is coiled in the manner of an involute, so as to make several coils before it reaches the rim of the disk. This flange should be about two inches in height; but this also will depend upon circumstances. This involute flange I secure to the face of the disk, so that it forms a coiled riffle, as shown.

On the under side of the disk, near its periphery, is a flange, *f*, the under side of which I form with ratchet-teeth. *h* is a pawl, which is connected with a crank, *k*, on the driving-shaft, and held by a weight, *i*, against the ratchet-rim, so that at each rotation of the driving-shaft the pawl will fall back and engage with one of the ratchet-teeth and push the disk around, thus giving to the disk an intermittent rotary motion.

l is a perforated water-pipe, which is arranged to extend across the descending side of the disk directly opposite its center, so as to form a sprinkler for supplying water for washing the material.

The pawl *h* and ratchet-teeth are arranged

to rotate the disk in a direction opposite to that in which the involute flange coils, so as to cause anything which is caught against the flange to travel toward the center of the disk when the disk rotates.

The pulp or other material to be separated I feed upon the lower edge of the disk A, so that it will be caught by the outer coil and carried up under the sprinkler *l*. The water will wash the lighter particles over the rim or flange and carry it down the inclined face of the pan, while the heavier particles will be caught by the involute riffle and moved by the rotation of the disk gradually toward the center opening. Each revolution of the disk will carry the heavy particles one coil nearer the center of the disk, and once during each revolution will the material be carried under the sprinkler and washed until it is dumped into the central opening, from whence it is conducted to a proper receptacle.

Two or more involute riffles could be used, and any shaking progressive rotation could be applied; or, if desired, a concussion could be applied to the disk at the instant, or just after each partial rotation. These, however, would be incident to the machine, and not material to be described.

Having thus described my invention, what I claim, and desire to secure by Letters Patent, is—

1. The disk A, with its central opening, C, mounted at an angle, and provided with the involute riffle *e*, said disk having imparted to it a rotary motion, either intermittent or continuous, substantially as and for the purpose described.

2. The inclined disk A, with its central opening, C, and involute riffle *e*, in combination with the sprinkler or water-pipe *l*, substantially as and for the purpose described.

In witness whereof I have hereunto set my hand and seal.

FRANK A. HUNTINGTON. [L. S.]

Witnesses:

CHARLES D. COLE,
J. H. BLOOD.