

F. A. HUNTINGTON.
Ore-Stamp.

No. 210,610.

Patented Dec. 10, 1878.

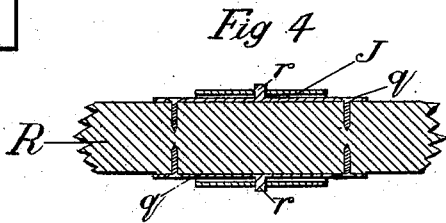
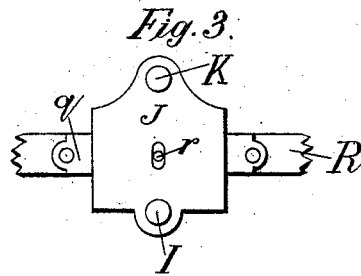
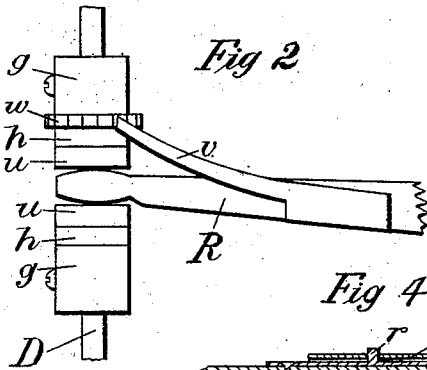
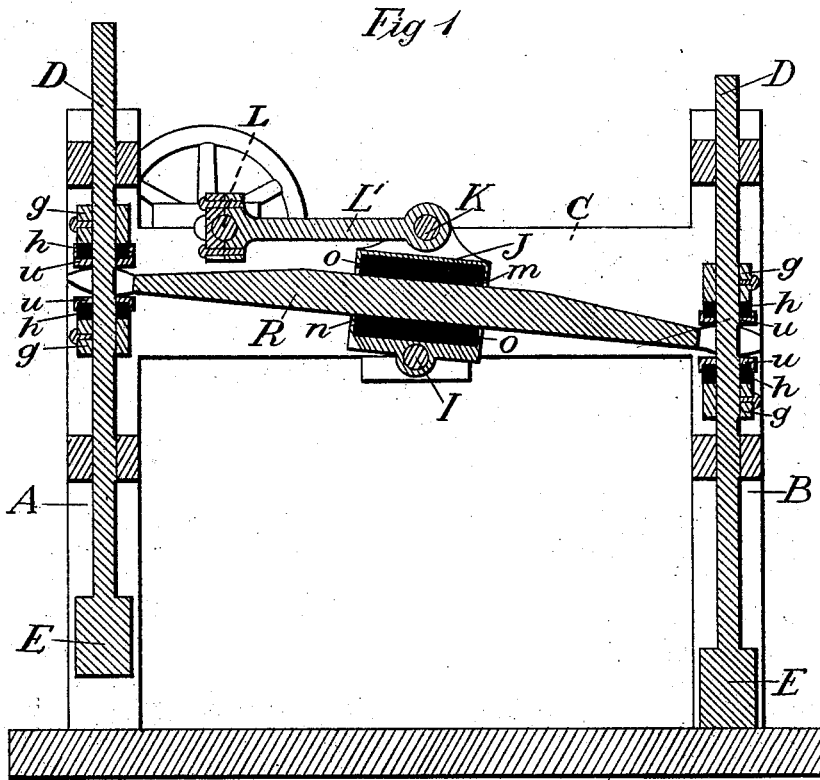

Witnesses
W. F. Clark
D. B. Lawler.

Inventor
Frank A. Huntington
per Jno. L. Boone
Attorney

UNITED STATES PATENT OFFICE.

FRANK A. HUNTINGTON, OF SAN FRANCISCO, CALIFORNIA.

IMPROVEMENT IN ORE-STAMPS.

Specification forming part of Letters Patent No. **210,610**, dated December 10, 1878; application filed September 7, 1878.

To all whom it may concern:

Be it known that I, FRANK A. HUNTINGTON, of the city and county of San Francisco, in the State of California, have invented an Improved Stamp-Mill; and I do hereby declare that the following is a full, clear, and exact description thereof, reference being had to certain drawings accompanying this specification, and forming a part of the same.

My invention has reference to an improved stamp-mill for crushing quartz and other substances; and it relates to a novel arrangement for operating two stamps or sets of stamps by a single connection with the driving shaft or power, all as hereinafter more fully specified.

Referring to the accompanying drawing, Figure 1 is a vertical longitudinal section. Fig. 2 is a detached view of one arm, showing the ratchet and pawl. Fig. 3 is a view of the rocking box. Fig. 4 is a horizontal section of the lever-beam.

Let A and B represent two upright frames—such as are usually employed in the construction of stamp-mills for guiding the stamp-stem. These frames I place at a short distance apart, and connect them strongly together, near their upper ends, by connecting-beams C C, one on each side. This leaves sufficient space underneath the beam for a person to pass entirely around the batteries.

A stamp-stem, D, passes up through the cross-beams of each of the frames A and B, and a stamper, E, is secured to the lower end of each stem, in the ordinary manner of constructing stamp-mills. These two stamps I then operate alternately by a single connection with the driving shaft or power in the following manner: On each stem I secure two tappets, which I shall characterize as "upper" and "lower" tappets. These tappets are secured to the stem at a short distance apart, one above the other. I is a fixed shaft, which extends across underneath the two connecting-beams C C, midway between the two stamp-frames A B, and on this shaft I place a box or frame, J, the shaft I passing through near the bottom of the box. This box has an opening or passage through it above the shaft, through which the walking-beam or operating-lever R passes, while its sides extend upward and are

connected by a pin or shaft, K, with the crank-shaft L, which is also the driving-shaft, so that a rotary motion of the crank or driving shaft is converted by the pitman L' into a reciprocatory motion, and thus communicated to the box J.

The walking-beam or lever R is long enough to extend from one stamp-stem to the other. It is made thickest and strongest at the middle, where it passes through the box J, and tapers or flattens gradually toward its ends.

Instead of securing the walking-beam in the box by passing a shaft through the sides of the box and through its middle, so as to form a middle support similar to trunnions, I prefer to secure a plate, *g*, on each side of the beam, from which plate a short journal or trunnion, *r*, projects through the hole in the side of the box. I thus avoid weakening the beam by passing a shaft through it; and as the plates are secured to the beam by screws, it is easy to remove them, so that the beam can be withdrawn from the box when desired.

I make a chamber, *m*, in the box above the beam or lever, and another, *n*, below it, and in these chambers I place india-rubber or other elastic cushions *o*, which will yield both up and down when a strain is brought to bear upon the outer ends of the beam or levers. The holes in the sides of the box, in which the trunnions *r* bear, are elongated vertically, so that the middle of the beam will have a motion equal to the length of the hole or slot. The levers or arms of the walking-beam could be made thin enough to serve as spring-arms, if desired, in which case the cushions in the box could be dispensed with.

The extremity of each arm is bifurcated, so that one branch will pass on each side of the stamp-stem, between the upper and lower tappets, leaving the stem free to work loosely between them, while the branches serve, by striking the tappet above, to lift the stamp and stem and to force them down again by striking the lower tappet.

I prefer to provide each of the tappets with a cushion or spring. This is done by making each tappet in three parts—first, a solid metallic tappet, *g*, which is keyed or otherwise secured to the stem; second, a cushion, *h*, of

india-rubber; and, third, a metallic ring *u*, which is cup-shaped, to receive the cushion, all arranged as shown.

It will be noticed that this is not a rubber tappet, but a metallic tappet with an interposed spring, which can be made either of rubber or metal. This arrangement gives a resilience to the blow of the stamp, which produces better results than a dead blow or drop, and it also relieves the effect of the blow upon the other parts of machinery.

I can arrange a series of stamps on each side, and connect each two opposite stamps by a single walking-beam, so that all the walking-beams will pass through the same box, and thus operate them all by a single connection with the crank or driving shaft. I thus obtain a quick and steady motion, that will be more effective for crushing and cause less strain upon the driving-power.

Ordinarily, the stamps will rotate sufficiently to cause them to wear evenly, especially if I cut away one of the branches on the end of the levers, so that the lift will be on one side of the stem when the ordinary cam is used; but in case a more positive rotation is required, I form the lower edge of the upper fixed metallic tappet, *g*, into a ratchet, *w*, as shown, and arrange a spring-pawl, *v*, to engage with it and rotate the stamp and stem when they drop. This pawl will spring back when the stamp rises, ready to engage the ratchet when it descends.

Having thus described my invention, what I claim, and desire to secure by Letters Patent, is—

1. The battery-frames A B, placed opposite each other, and connected near their upper ends by the beams C, in combination with the walking-beam R and the tappets *g h u* on the stamp-stem, substantially as and for the purpose specified.

2. The battery-frames A B, connected as described, and having their stamp-stems D provided with two tappets, *g h u*, which are secured at a short distance apart, in combination with the walking-beam R, mounted at its middle in the rocking box J, while its extremities pass between the two tappets on the stamp-stem, substantially as and for the purpose specified.

3. The box J, mounted at its lower side on a shaft, I, and connected at its upper side with the crank-shaft L by a pitman, L', said box having a passage for the walking-beam R and the cushion-chambers *m n*, substantially as and for the purpose specified.

4. The walking-beam R, having the plates *g*, with their trunnions *r* secured to its sides, in combination with the rocking box J, with its elongated holes and cushions *o*, substantially as and for the purpose described.

5. The walking-beam R, provided with the pawl *v*, in combination with the tappet having the ratchet *w*, for revolving the stamp, substantially as specified.

In witness whereof I have hereunto set my hand and seal.

FRANK A. HUNTINGTON. [L. s.]

Witnesses:

CHARLES D. COLE,
J. H. BLOOD.