

H. TABOR.
Indicator for Steam-Engines, &c.

No. 210,643.

Patented Dec. 10, 1878.

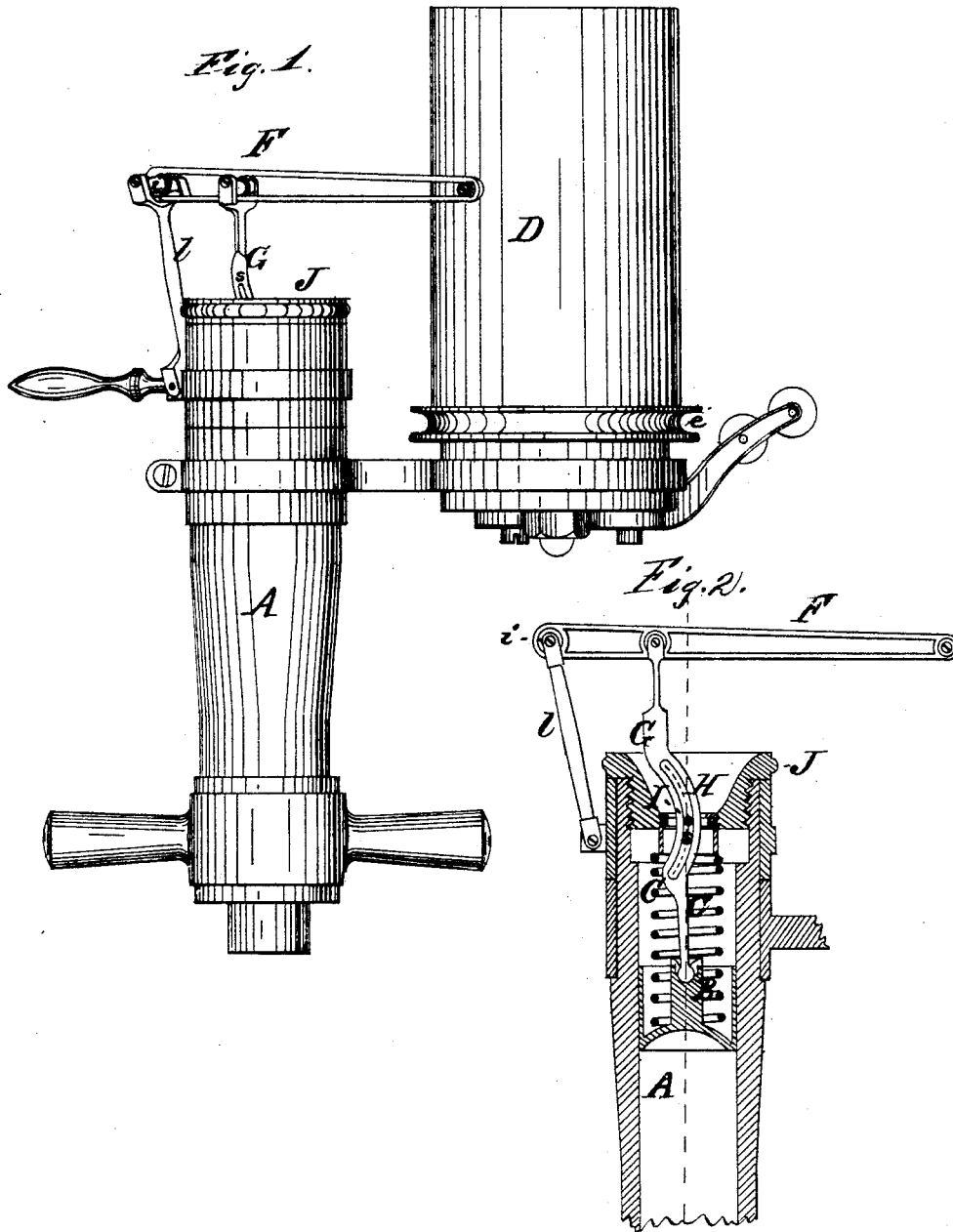

Witnesses
H. L. Bennett.
H. H. Isaacs

Inventor.
Harris Tabor
by his Atty.
C. S. Kenwick

UNITED STATES PATENT OFFICE.

HARRIS TABOR, OF CORNING, NEW YORK.

IMPROVEMENT IN INDICATORS FOR STEAM-ENGINES, &c.

Specification forming part of Letters Patent No. **210,643**, dated December 10, 1878; application filed October 30, 1878.

To all whom it may concern:

Be it known that I, HARRIS TABOR, of Corning, in the county of Steuben and State of New York, have made an invention of certain new and useful Improvements in Indicators, parts of which are applicable to other purposes; and that the following, taken in connection with the accompanying drawings, is a full, clear, and exact description and specification of the same.

The object of this invention as applied to indicators is to reduce the number and weight of the reciprocating moving parts of the instrument, and consequently to render it more accurate and better adapted to record the action of steam when the engine to which the indicator is applied is running at a high rate of speed.

To this end my invention consists of certain combinations of the vibratable or vibrating indicator-lever, or its substitute, with certain devices for causing the point thereof to describe a straight line, notwithstanding the fact that the lever vibrates and varies its inclination to a central line. These combinations are recited in detail in the claims at the close of this specification.

In order that they may be fully understood, I have represented in the accompanying drawing, and will proceed to describe, a steam-engine indicator embodying my invention in the best form in which I have embodied it at the present date.

Figure 1 of said drawings represents an elevation of said indicator. Fig. 2 represents a section of a part thereof.

The cylinder A of the indicator represented in said drawings is of the usual construction, and is fitted with a piston, B, which is pressed against the steam under the piston by the spring C. The movement of this piston by the varying pressure of the steam on one side and by the spring on the other indicates the varying pressure, which is recorded by the action of a pencil-point upon a sheet of paper. The sheet of paper is supported upon the paper-roller D, which is secured at one side of the indicator-cylinder A, and is fitted with a cord-pulley, e, so that the paper-roll may be turned to and fro on its axis in the usual manner at each revolution of the steam-engine by means

of a cord connected with some moving part of the engine.

The pencil is so held by the vibrating or vibratable lever F that the pencil-point bears upon the surface of the paper on the paper-roll. This lever F is connected with the piston B, and also has its fulcrum connected with the indicator-cylinder, so that the lever vibrates with the movements of the piston. In order that the pencil end of the lever F may describe a straight line parallel with the axis of the paper-roll, the lever is combined with the piston B through the intervention of a link, G, whose lower end is jointed to the piston, whose upper end is jointed to the indicator-lever, and which has a curved body, H, that is guided by the stationary guide I, which, in this example, is secured in the opening of the cylinder-head J. The guide I has in this case the form of a round pin, extending cross-wise through a curved guide-slot, s, in the guide-body H; and the action of the stationary guide upon this guide-slot causes the link to move laterally to and fro as the piston moves it up and down. The lateral movement of the link compels the indicator-lever to which it is jointed to move endwise as it vibrates up and down, and thus causes the outer or indicating end of the lever to deviate from the arc of a circle. In order that the lever may be permitted to move endwise as it vibrates, its fulcrum-pivot i is connected with the indicator-cylinder by a swinging link, l; and in order that the indicating or pencil end of the lever may move in a straight line, the guide-slot s is made of the proper curvature to give the lever the necessary endwise movement for that purpose. This curvature may be laid out geometrically, or it may be readily obtained by holding a pencil-point or a scratch-awl at one side of a blank or unslotted guide-body in the position of the center of the guide-pin I, and by moving the lever up and down with a point in its indicating end following a straight-edge. The pencil or scratch-awl will then describe a curve upon the side of the blank guide-body, and this curve will be the middle line of the slot of proper curvature.

In this combination of the lever with the curved guide-body and guide the link per-

forms the function of connecting the lever with the indicator-piston, while the curved guide-body and guide compel the indicating end of the lever to describe a straight line. The connection of the piston and lever is direct, and the moving parts are reduced to the smallest possible number, and their combined weight is also small.

The steadiness with which the apparatus operates in practice is remarkable, even when indicating the pressure of the steam in the cylinders of steam-engines making upward of two hundred revolutions per minute.

The construction of the instrument may be considerably varied without ceasing to embody my invention. Thus, for example, in place of arranging the indicator-lever to vibrate on a fulcrum-pivot connected with the cylinder by a swinging link or stanchion, the fulcrum-pivot may be connected with a fixed stanchion, and the fulcrum end of the lever may be constructed to slide endwise through or upon the fulcrum-pivot. The curved guide-body also, instead of being intermediate between the lever and the piston, may form an extension of the guide-link above the lever, the guide in such case being also arranged above the lever and held in place by a suitable stay or support. The curved guide-body need not necessarily form a part of the link, because the guide-body and guide may be transposed, the former being fixed to the head of the cylinder, while the latter is carried by the vibratable lever, or by a plain link, and traverses the curved guide-slot of the guide-body, so that the lever is caused to move endwise, and the pencil-point may be compelled to move in a straight line. The guide-body also may have the cross-section of a rod, while the guide has

the form of an eye, through which the rod-formed body slides; but in this case the guide should be permitted to turn on an axis crosswise of the direction of motion of the guide-link, so as to adapt the position of the guiding-eye to the varying inclination of the curved body of the link. When the guide-body has a curved guide-slot running on a guide-pin, the edges of the body itself need not necessarily be curved, it being essential only that the portion of the curved guide-body upon which the guide operates shall have the proper curvature.

The lever, curved guide-body, guide, and link may be used for other purposes than an indicator—as, for example, to combine two devices which are to reciprocate parallel with each other, but with different lengths of stroke—and I intend to use this combination wherever its use is expedient.

I claim as my invention—

1. The combination, substantially as before set forth, of the vibratable lever, the link, the curved guide-body, and the guide.
2. The combination, substantially as before set forth, of the piston, the link, the curved guide-body, the guide, and the vibratable lever.
3. The combination, substantially as before set forth, of the piston, the curved guide-body, the guide, the link, the vibratable lever, and the paper-roll.

In witness whereof I have hereto set my hand this 17th day of October, A. D. 1878.

HARRIS TABOR.

Witnesses:

A. N. SILL,
DAVID W. PAYNE.