

J. BOYLE.
Reversible Wagon Cover.

No. 210,662.

Patented Dec. 10, 1878.

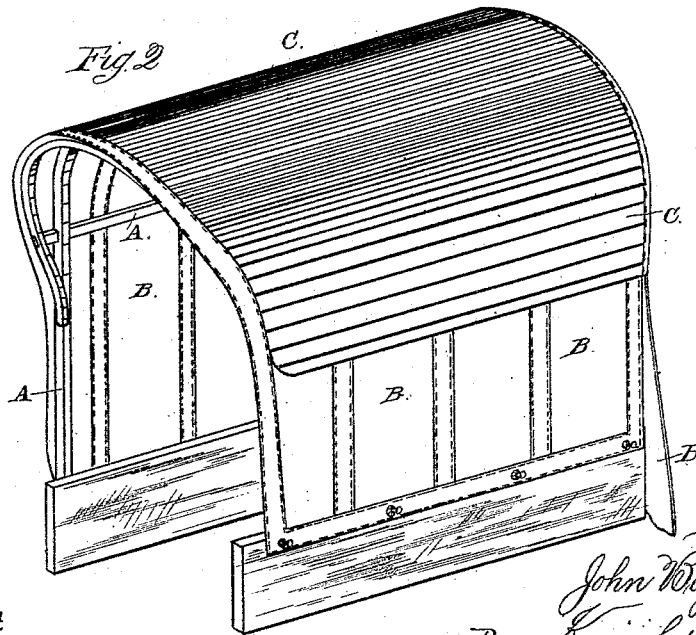
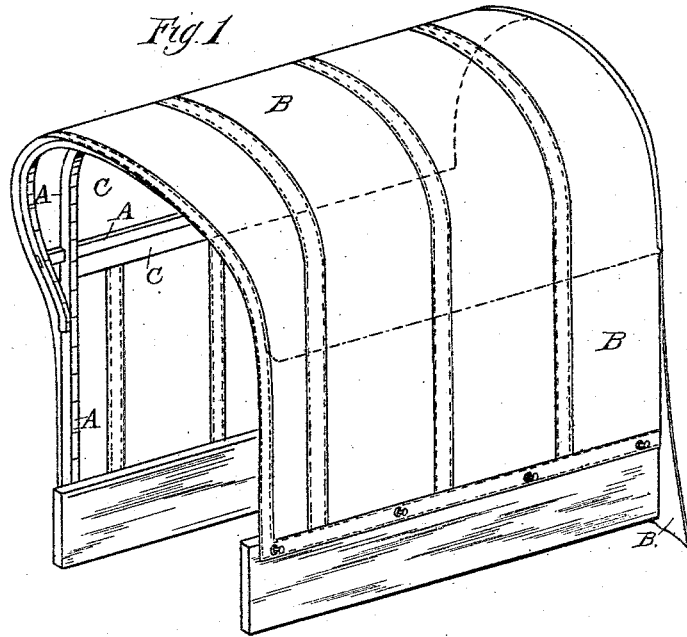

Attest:
Geo. T. Smallwood Jr.
Walter Allen

Inventor:
John Boyle.
By *Knight Bros.*
Attys.

UNITED STATES PATENT OFFICE.

JOHN BOYLE, OF NEW YORK, N. Y.

IMPROVEMENT IN REVERSIBLE WAGON-COVERS.

Specification forming part of Letters Patent No. **210,662**, dated December 10, 1878; application filed May 29, 1878.

To all whom it may concern:

Be it known that I, JOHN BOYLE, of the city, county, and State of New York, have invented certain new and useful Improvements in Bow-Covers for Wagons, of which the following is a specification:

The subject of my invention is a reversible bow-cover for wagons, provided at top with a lining of oiled or painted canvas, or other water-proof material, which, when placed next the bows, protects the body of the cover from wear therefrom, and, being placed outside in rainy weather, serves as a perfect protection from the wet.

In order that my invention may be more clearly understood, I will proceed to describe it with reference to the accompanying drawing, in which—

Figure 1 is a perspective view of the cover as used in fair weather, the dotted outline showing the form of the connected lining. Fig. 2 is a perspective view of the cover in reversed position, with the water-proof lining exposed.

A A represent parts of the bow-frame of a wagon of common form. B is the main body or portion of the cover, extending over the top and down the sides and back, as usual. C is the water-proof lining, secured within or beneath the top of the cover B, so as to extend slightly over the shoulders or bends of the bows on either side.

When my improved cover is in the position

shown in Fig. 1, the lining C serves as a re-enforce, and effectually protects the canvas B from contact or wear from the bows A A.

When in reversed position, as illustrated in Fig. 2, the lining or re-enforce serves as a complete protection from rain.

The additional roof or lining C may be composed of rubber, enameled, oiled, or otherwise waterproofed fabric. It extends across the roof, and down the sides sufficiently to prevent chafing of the supporting-frame, and to throw off the water perfectly where it is most liable to lodge—namely, on the flat, or partially flat, portion of the cover.

Among the advantages of my improved cover may be mentioned lightness, cheapness, and perfect repellent qualities, as the cover can be made of much lighter material, by reason of the exposed parts being double and protected by a re-enforce adapted to resist both wear and water. Chafing of the frame is prevented and durability increased.

Having thus described my invention, what I claim as new therein, and desire to secure by Letters Patent, is—

The reversible wagon-bow cover provided with a lining, C, of water-proof material extending over its horizontal portion, as and for the purposes described.

JOHN BOYLE.

Witnesses:

JAMES H. AYMAR,
G. O'CONNOR.