

P. BRAND & E. J. KING.
Gas-Light Extinguisher.

No. 210,663.

Patented Dec. 10, 1878.

Fig. 1.

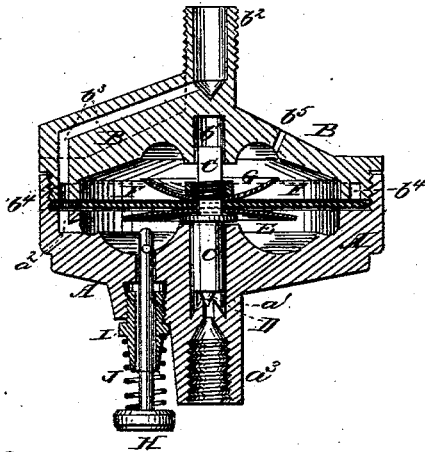

Fig. 2.

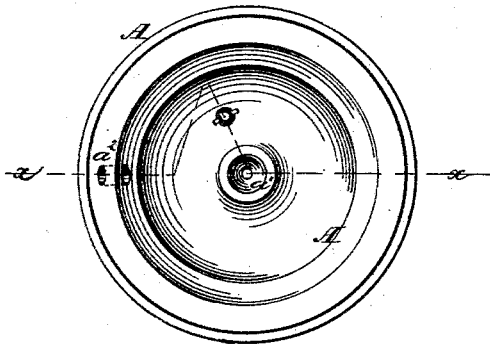
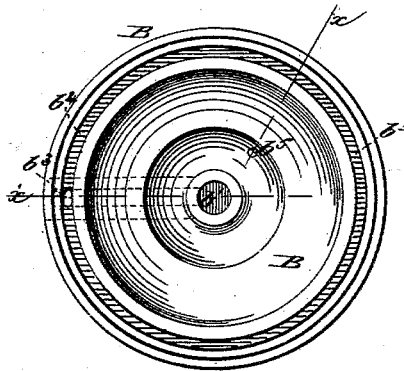

Fig. 3.



WITNESSES:

Francis McChesley,
Chas. Sedgwick

INVENTOR:

P. Brand
E. J. King
Munn & Co

BY

ATTORNEYS.

UNITED STATES PATENT OFFICE.

PHILIPP BRAND AND EDWARD J. KING, OF JACKSONVILLE, ILLINOIS.

IMPROVEMENT IN GAS-LIGHT EXTINGUISHERS.

Specification forming part of Letters Patent No. **210,663**, dated December 10, 1878; application filed November 16, 1878.

To all whom it may concern:

Be it known that we, PHILIPP BRAND and EDWARD JOSEPH KING, of Jacksonville, in the county of Morgan and State of Illinois, have invented a new and useful Improvement in Gas-Light Extinguishers, of which the following is a specification:

Figure 1 is a detail section of one of our improved extinguishers, taken through the broken line *x x*, Figs. 2 and 3. Fig. 2 is a detail view of the lower part of the case. Fig. 3 is a detail view of the upper part of the case.

Similar letters of reference indicate corresponding parts.

The object of this invention is to improve the construction of the gas-light extinguisher for which Letters Patent No. 206,926 were granted to us August 13, 1878, so as to make it simpler in construction and less expensive in manufacture, while being equally sensitive to variations in the gas-pressure.

The invention consists in the combination of the lower part of the case, provided with the socket, the tubular projection, and the port, the upper part of the case, provided with the socket, the tubular projection, the port, the ring-groove, and the air-hole, the valve-stem and valve, the disk, the flexible diaphragm, and the weight-cup with each other; and in the combination of the lower part of the case, provided with the socket, the tubular projection, and the port, the upper part of the case, provided with the socket, the tubular projection, the port, the ring-groove, and the air-hole, the valve-stem and valve, the disk, the flexible diaphragm, the weight-cup, and the rod, stuffing-box, and spring with each other, as hereinafter fully described.

A represents the lower part of the case, which is rabbeted upon the inner side of its edge and has a screw-thread cut in it to receive a similar screw-thread cut in the rabbeted outer part of the edge of the upper part, B, of the case. The inner surfaces of the two parts A B of the case are concaved around their centers, and in the central projections thus formed are formed sockets *a' b'*, to receive and serve as guides for the ends of the valve-stem C, which is made enough shorter than the distance between the bottoms of the

said sockets to give the valve the necessary play.

The socket *b'* of the upper part, B, of the case is directly opposite the tubular projection *b''*, formed upon the center of the outer surface of the said part, and upon the outer surface of which is formed a screw-thread to receive the burner. From the inner end of the cavity of the projection *b''* a port or passage, *b''*, leads down through the wall of the part B, and terminates in a ring groove or channel, *b''*, formed in the edge of the said part B, which edge rests upon the rabbet-shoulder of the edge of the lower part, A.

a'' is a port or passage formed through the rabbet-shoulder of the edge of the part A. The upper end of the port *a''* is directly beneath the groove *b''* of the part B, and its lower end opens into the cavity of the part A, so that gas can pass from the said cavity through the port *a''* to the groove *b''*, and thence through the port *b''* to the gas-burner.

The socket *a'* of the lower part, A, is directly opposite the tubular projection *a''*, formed upon the center of the outer surface of the said part, and has a screw-thread cut in its inner surface to receive a gas-pipe. Through the partition between the cavity of the projection *a''* and the socket *a'* is formed a small hole for the passage of the gas, and the upper end of which serves as a seat for the conical valve D, formed upon the lower end of the valve-stem C. Upon the valve-stem C, just above the inner surface of the part A, is a small metallic disk, E, which rests upon a shoulder or collar formed upon or attached to the said valve-stem C. Upon the valve-stem C, above the disk E, is placed a flexible diaphragm, F, of leather, rubber, or other suitable material, that will not be affected injuriously by the gas, and which is made of such a size that its edge may be clamped between the grooved edge of the part B and the rabbet-shoulder of the part A, the grooved edge of the part B forming a double seat for the said diaphragm, and thus making a closer joint and more effectually preventing the escape of gas.

In the diaphragm F, directly beneath the groove *b''*, and directly above the upper end of the port *a''*, is formed a hole to allow the gas

to pass from the said port a^2 to the said groove b^4 .

Upon the valve-stem C, above the diaphragm F, is placed a cup-shaped disk, G, to receive weights for adjusting the valve to any desired gas-pressure. The weight-cup G, the diaphragm F, and the disk E are secured in place by a nut screwed upon the valve-stem C.

In the part B is formed a hole, b^5 , to allow air to pass out of and into the cavity of the said part as the diaphragm F is moved up and down.

H is a rod which passes up through a hole in the part A, and through a stuffing-box, I, inserted in the enlarged outer end of the said hole. The rod H is held out by a coiled spring, J, placed upon its outer part. The rod H is kept from coming out by a pin passed through its inner end.

With this construction, when the gas is to be lighted, the valve D is raised from its seat to admit the gas by pressing the rod H upward against the disk E, and is held up by the pressure of the gas upon the lower side of the diaphragm F. When the pressure of the gas is diminished the valve is forced to its seat by the weight in the cup G, and cannot be raised from its said seat by the gas-pressure, however much the said pressure may be increased. The air-hole b^5 is designed to be formed directly over the weight-cup G, so that

shot can be dropped through it into the said weight-cup for weighting the valve to the desired pressure without its being necessary to take the device apart for this purpose.

Having thus described our invention, we claim as new and desire to secure by Letters Patent—

1. The combination of the lower part, A, provided with the socket a^1 , the tubular projection a^3 , and the port a^2 , the upper part, B, provided with the socket b^1 , the tubular projection b^2 , the port b^3 , the ring-groove b^4 , and the air-hole b^5 , the valve-stem and valve C D, the disk E, the flexible diaphragm F, and the weight-cup G with each other, substantially as herein shown and described.

2. The combination of the lower part, A, provided with the socket a^1 , the tubular projection a^3 , and the port a^2 , the upper part, B, provided with the socket b^1 , the tubular projection b^2 , the port b^3 , the ring-groove b^4 , and the air-hole b^5 , the valve-stem and valve C D, the disk E, the flexible diaphragm F, the weight-cup G, and the rod, stuffing-box, and spring H I J with each other, substantially as herein shown and described.

PHILIPP BRAND.

EDWARD JOSEPH KING.

Witnesses:

JNO. G. LOOMIS,
J. R. MCAHAN.