

T. GALLOWAY & J. LARSEN.
 Combined Broadcast Seeder, Cultivator and
 Grain-Drill.
 No. 210,683. Patented Dec. 10, 1878.

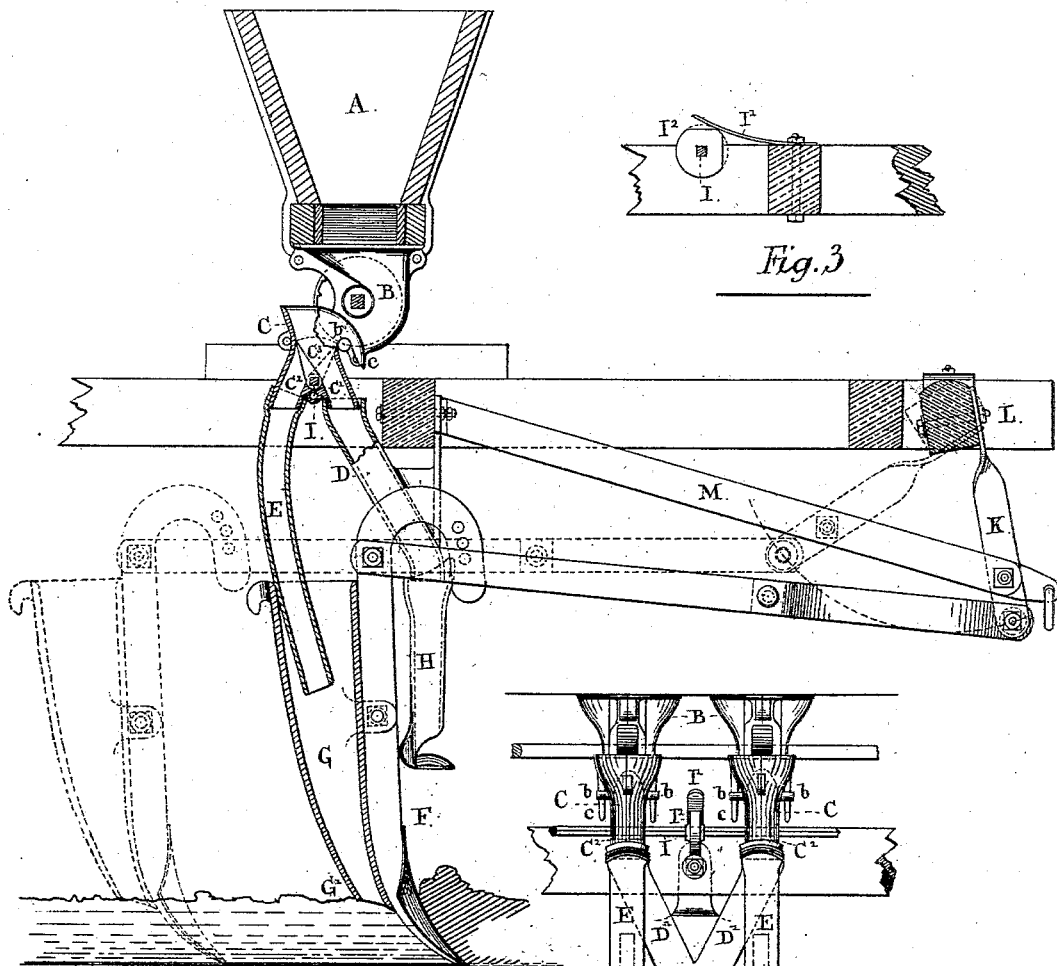

Fig. 1.

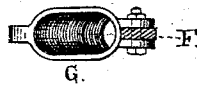

Fig. 4

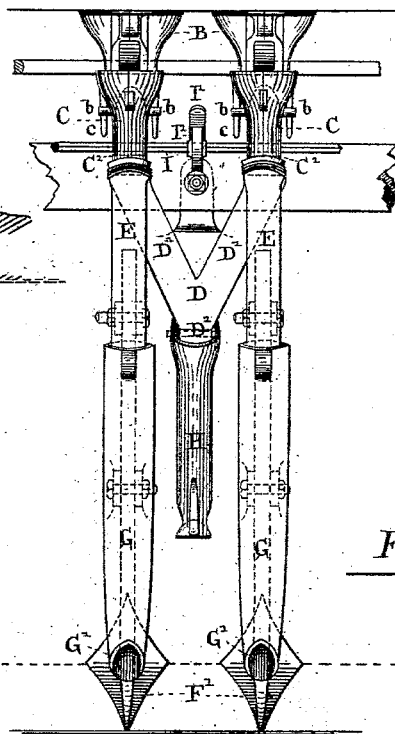

Fig. 2.

Witnesses:

L. Whitehead.

A. E. Cowan.

Inventors:

Thomas Galloway

John Larsen

by Kidout Bird & Co. Attys.

UNITED STATES PATENT OFFICE.

THOMAS GALLOWAY AND JOHN LARSEN, OF OSHAWA, ONTARIO, CANADA.

IMPROVEMENT IN COMBINED BROADCAST-SEEDER, CULTIVATOR, AND GRAIN-DRILL.

Specification forming part of Letters Patent No. **210,683**, dated December 10, 1878; application filed March 18, 1878.

To all whom it may concern:

Be it known that we, THOMAS GALLOWAY and JOHN LARSEN, both of Oshawa, in the county of Ontario, in the Province of Ontario, Canada, have jointly invented a certain new and useful Combined Broadcast-Seeder, Cultivator, and Grain-Drill, which invention is fully set forth in the accompanying drawing and specification.

Our invention has relation to improvements in the construction of seeding-machines, by which improvements the advantages of a separate broadcast-seeding and cultivating machine and a separate grain-drill are combined in one implement, in such manner that the implement can be used for sowing grain by broadcast or by drilling, as the requirements of different descriptions of land require.

The invention consists, first, in arranging a series of swinging valves upon a shaft, and in adapting said valves to be held in the required position, whereby grain may be allowed to fall from the hopper, through angularly-placed discharge-passages controlled by said valves, to scattering-tubes in front of the hoes or to the drill-tubes.

The invention consists, secondly, in combining a scattering-tube with a hopper having divergent grain-passages and swinging valves.

The invention consists, thirdly, in combining, with grain-distributers and hoppers having divergent grain-passages and swinging valves, certain flexible tubes and drill tubes and teeth.

The invention consists, fourthly, in an arrangement of parts whereby the position of the teeth may be adjusted for use when the grain is to be sown by drilling or broadcast, all as hereinafter more fully described.

In the accompanying drawings, Figure 1 is a longitudinal section, in part, of a machine embodying our invention. Fig. 2 is a rear elevation of the same. Figs. 3 and 4 are details.

A is the grain-box of machine, supported in the usual way, and provided with grain-distributers, B, of any of the usual types. The general arrangement of the parts of the machine not illustrated may be that of any of the well-known grain-drills or seeders now in

use, our improvements, with slight alterations of construction, being applicable to all, and not to any one particular style.

b are projecting studs cast on each side of the distributers B, on which studs the hoppers C are supported, by the hooks c, in a working connection with the distributers. The hoppers C are provided with two angularly-placed discharge-passages, C¹ C², the former leading to the mouth of the tubes D, connecting with the scatterers H, in front of the hoes F, and the latter leading to the mouth of the flexible tubes E, connecting with the drill-tubes G.

The openings to the passages C¹ C² from the hopper are controlled by a swinging valve, C³, the proper movement of which shuts off either passage, as desired. These swinging valves throughout the whole machine are securely and uniformly mounted upon a rod or shaft, I, so that by means of a suitable handle, lever, or wheel the whole system of valves can be simultaneously moved by one movement of the rod I, to shut off or open either of the sets of grain-passages. The valves are retained in position by the action of a spring, I¹, bearing upon the projecting faces of a block, I², fastened to the rod I, as shown in Fig. 3.

The grain-conductor tubes D, which lead the grain to the scatterers, consist of two separate branch tubes, D¹ D², joined together at their lower ends in a common outlet, D³, but spreading sufficiently apart at the top to serve two distinct distributers. These tubes discharge into the scatterers H. The scatterers are connected to the tubes D by a flexible joint, or by any other suitable joint that will permit them to swing backward when they strike an obstruction; and it is obvious that a spring could be used to return the scatterers to their place, if desired.

The tubes E, leading to the drill-tubes, are hung or fastened to the hopper-pieces C, and are arranged to swing freely in the direction of the length of machine.

The grain-drill tubes G are of substantially the usual construction, with the exception that more clearance than usual is given to the back of the delivery end G'. The tubes G are fastened in a secure manner to and in the rear of

the cultivators F, the lower ends of the tubes terminating at a point at or about the center of the hoe, thus forming a tooth which can be used either for grain-drilling or broadcast-seeding.

The combined drill and cultivator tooth may be connected to the drag-bar in a fixed position, or can be attached to spring locking devices, as desired.

The front ends of the drag-bars are connected to hangers K, which hangers are mounted on a pivoted supporter, L, in such manner that the position of the teeth can be altered to suit the description of sowing to be done—that is, when the grain is to be sown by drilling, the teeth are placed in the forward position, (shown by full lines in Fig. 1,) and when the grain is to be sown broadcast the teeth are moved back to the position shown by dotted lines in Fig. 1. The teeth are secured in position for either service by detachable pins passed through the hangers and the braces U.

In the construction of broadcast-seeders but one grain-conducting tube is necessary for two hoes, while in the grain-drill a separate grain-conducting tube is required for each hoe. A less number of distributors, therefore, is required in a broadcast-seeder than in a grain-drill. The grain, also, in the broadcast-machine is distributed between and a short distance in front of the hoes, while in the grain-drill the grain is discharged immediately behind each hoe. The requirements of the two separate systems we have successfully overcome by the use of the branched conductor-tube D.

Hitherto the difficulties attending the working of land have required the services of two separate machines—the one adapted to perform the work that the other was unfitted for. These separate necessary and distinct qualifications of the two machines we now combine in a single machine which can perform either class of work in the most efficient manner.

We claim as new and desire to secure by Letters Patent—

1. The shaft I, having a series of valves, C³, secured thereto, and provided with the block I², combined with the spring I¹, substantially as described.

2. The hopper C, provided with divergent grain-passages C¹ C², having swinging valves C³, combined with the grain-conductor tubes D, with divergent branches D¹ D², and a scattering-tube, substantially as set forth.

3. The distributors B and hoppers C, having divergent grain-passages C¹ C², and swinging valves C³, combined with the tubes E and teeth G F, all arranged substantially as set forth.

4. The pivoted supporter L, having the hangers K, combined with the drag-bars of a broadcast-seeder and grain-drill, and with the braces M, the central one of which serves also as a draft-bar, and detachable pins for securing the said hangers and braces together, substantially as set forth.

THOMAS GALLOWAY.
JOHN LARSEN.

Witnesses:

THOMAS J. H. BRIMICOMBE,
RICHARD McPHERSON.