

S. C. MATTESON.
Harrow.

No. 210,702.

Patented Dec. 10, 1878.

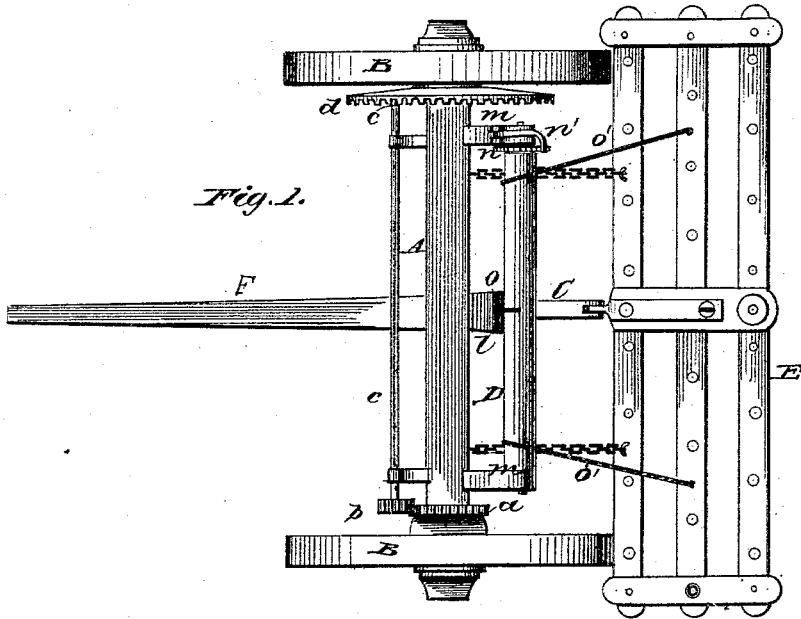

Fig. 1.

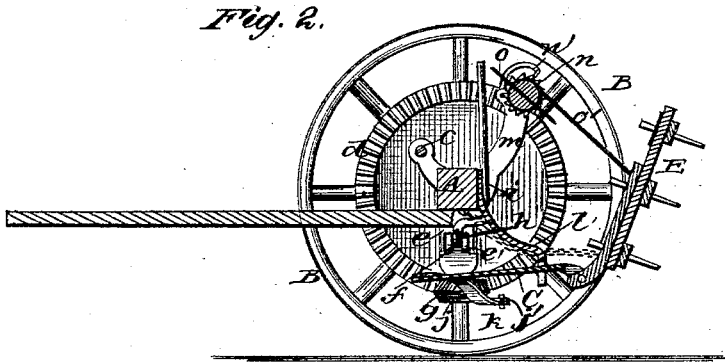

Fig. 2.

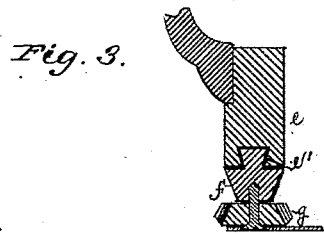

Fig. 3.

Witnesses:
Red G. Dietrich
George. Pinkenburg

Inventor:
Silas C. Matteson
by Louis Baggett
his attorney

UNITED STATES PATENT OFFICE.

SILAS C. MATTESON, OF CAMPBELLSPORT, WISCONSIN.

IMPROVEMENT IN HARROWS.

Specification forming part of Letters Patent No. 210,702, dated December 10, 1878; application filed August 29, 1878.

To all whom it may concern:

Be it known that I, SILAS C. MATTESON, of Campbellsport, in the county of Fond du Lac and State of Wisconsin, have invented certain new and useful Improvements in Harrows; and I do hereby declare that the following is a full, clear, and exact description thereof, reference being had to the accompanying drawings, and to the letters of reference marked thereon.

To enable others skilled in the art to which my invention appertains to make and use the same, I will now proceed to describe its construction and operation.

This invention relates to certain improvements in that class of devices termed "harrows," for pulverizing the land or plowed ground; and it consists in the particular adaptation and arrangement of a harrow with reference to an axle and its supporting-wheels, to enable it to receive vibratory motion as it is being drawn forward, and to be elevated out of the way when not in use, and vice versa, substantially as hereinafter more fully set forth.

Figure 1 of the drawings is a plan view of my improved harrow. Fig. 2 is a cross-section thereof, with the harrow itself in an elevated position. Fig. 3 is a detailed view of the slotted bracket supporting the shifting-lever, &c.

Corresponding parts in the three figures are denoted by like letters.

A refers to an axle, supported in an elevated position by the wheels B B, both of ordinary construction. Upon the end of the hub of one of the wheels B is a gear-wheel, *a*, with which gears a pinion, *b*, upon one end of a shaft or rod, *c*, journaled in bearings secured to the axle A, the other end of the shaft *c* being secured to an inwardly-beveled cog-wheel, *d*, fastened to the opposite end of said axle. From the lower side of the axle A, at a point contiguous to the wheel *d*, depends a projection or bracket, *z*, provided with a tapering or dovetailed slot or socket, *e*, to receive and support a correspondingly-shaped sliding journal-box, *f*, having a vertical shaft or axle supplied with a pinion, *g*, which en-

gages with the wheel *d*. To the sliding journal-box *f* is pivoted one end of a bar or rod, *h*, whose opposite end is connected to a lever, *i*, for shifting or throwing the pinion *g* in and out of gear with the wheel *d*. To the pinion *g* is fastened a collar, *j*, having an arm, *j'*, connected to a lever or bar, *k*, connecting with the tongue C of the harrow. By moving the hand-lever *i* so as to engage the pinion *g* with the wheel *d*, a vibratory motion will be imparted to the harrow, to assist it in its operation of pulverizing the earth or plowed ground. The tongue C is bent at its inner end and jointed or pivoted to the harrow, to possess it of a certain amount of flexibility, which is requisite to enable the parts to move freely, and to permit of the elevation of the harrow with as little friction as possible. The tongue C is supported and moves laterally in a slotted pendant or bracket, *l*, depending from the axle A, to accommodate it to the vibratory movement of the harrow.

Journaled in brackets or uprights *m m*, fastened to the axle A, is a roller, D, to one end of which is attached a ratchet, *n*, with which engages a pawl, *n'*, pivoted to one of the brackets *m*. Upon the axle A is mounted a seat for the driver, within convenient reach of whom extends a lever, *o*, from the roller D, to permit of its rotation. The harrow is connected to the roller D by means of ropes *o' o'*, chains, or other suitable medium.

The object of this mechanism is to permit of the elevation of the harrow out of the way when not in use, and vice versa.

E is the harrow, the beams of which have each an independent endwise movement to enable their teeth to readily move to one side of or clear of obstructions. F is the tongue of the axle, where the draft is applied.

This invention is also applicable to a seed-machine, or even to a corn-planter.

Having thus described my invention, I claim and desire to secure by Letters Patent of the United States—

1. The combination, with the harrow E, having a number of independently-moving tooth-beams, of the jointed tongue C, slotted tongue-support *l*, lever *k*, pinion *g*, gear-wheel

d, axle A, and wheels B, substantially as and for the purpose set forth.

2. The axle A, having a tapering or dove-tailed slotted bracket, *e e'*, in combination with the correspondingly-shaped journal-box *f*, whose shaft is provided with a pinion, *g*, and having a bar, *h*, lever *i*, collar and arm *j j'*, lever *k*, connected to the tongue of the harrow, and gear-wheel *d*, substantially as and for the purpose set forth.

In testimony that I claim the foregoing as my own I have hereto affixed my signature in presence of two witnesses.

S. C. MATTESON.

Witnesses:

GEO. C. DENNISTON,
PLATT DURAND.