

J. F. SHEEDER.  
Manufacture of Paper-Board.

No. 210,714.

Patented Dec. 10, 1878.

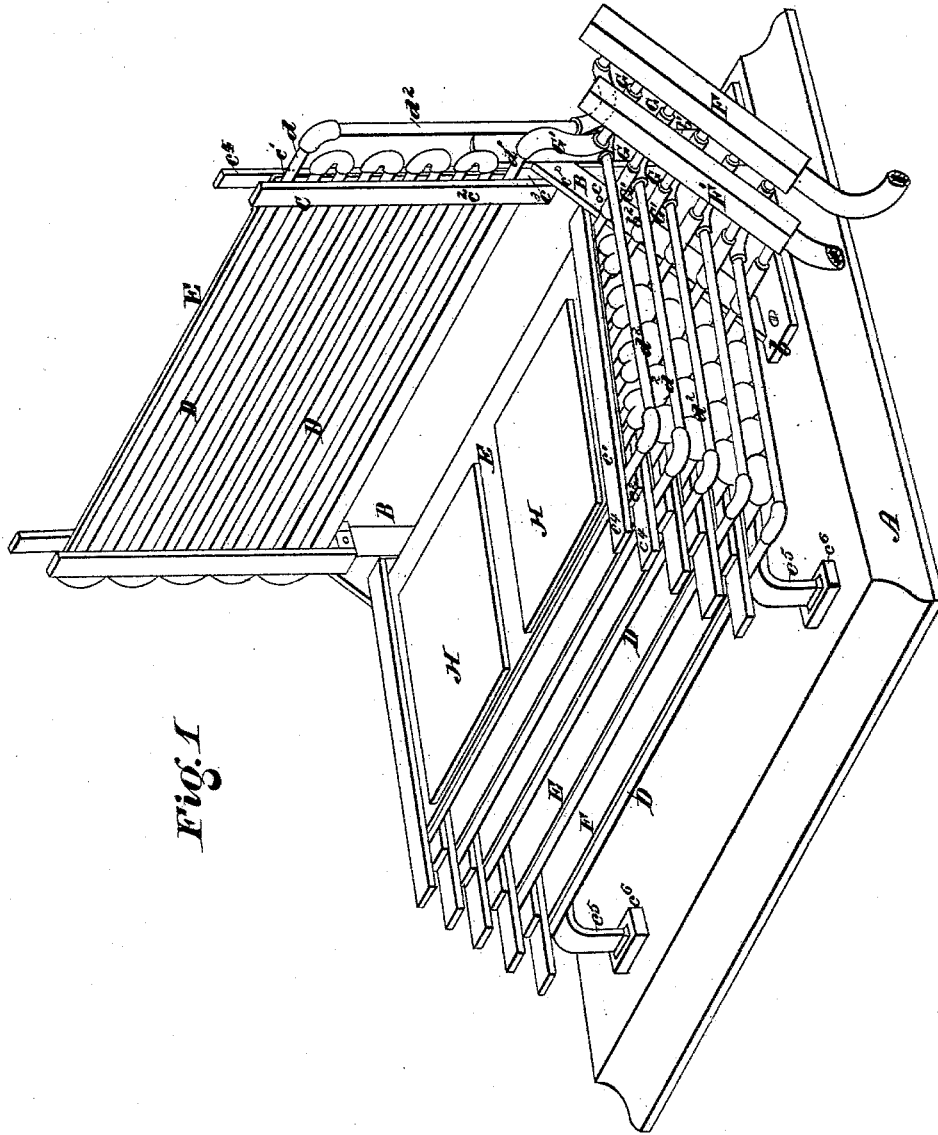

FIG. 1

WITNESSES:

*Saml. J. Vanstavern*  
*D. P. Cowl*

INVENTOR,

*J. Fred Sheeder*

*By Connolly Bros,*

ATTORNEYS.

J. F. SHEEDER.  
Manufacture of Paper-Board.

No. 210,714.

Patented Dec. 10, 1878.

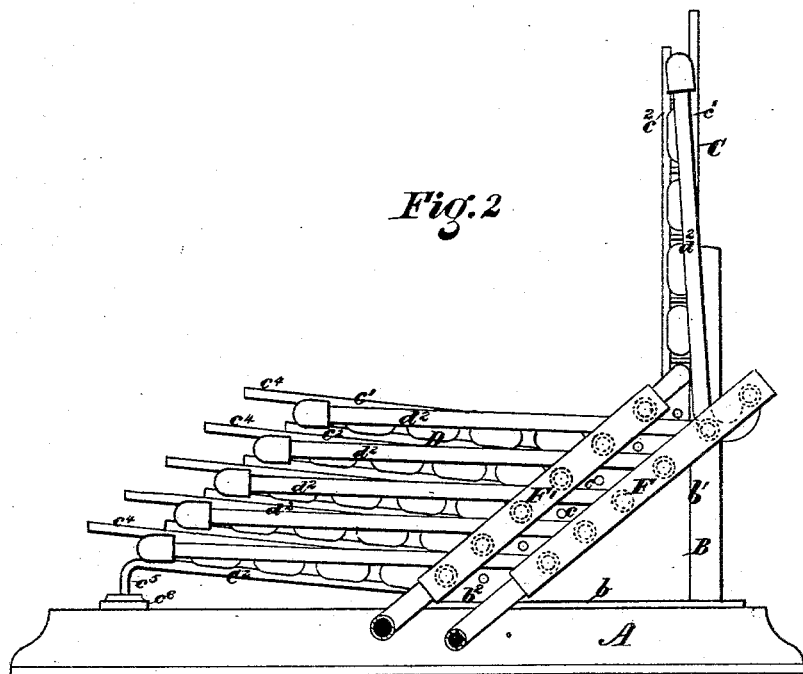

Fig. 2

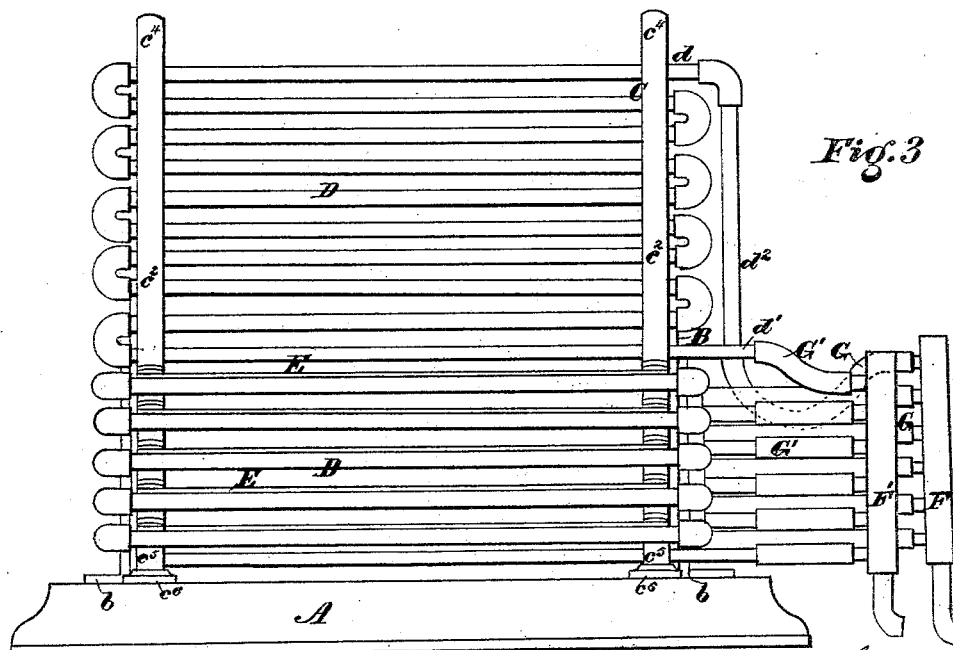

Fig. 3

Witnesses  
D. P. Cowl  
Saml. J. VanStavoren

J. Fred Sheeder *Inventor*  
By Connolly Bros *Attorneys*

# UNITED STATES PATENT OFFICE.

J. FREDERICK SHEEDER, OF KIMBERTON, PENNSYLVANIA.

## IMPROVEMENT IN THE MANUFACTURE OF PAPER-BOARD.

Specification forming part of Letters Patent No. 210,714, dated December 10, 1878; application filed October 14, 1878.

*To all whom it may concern:*

Be it known that I, J. FREDERICK SHEEDER, of Kimberton, in the county of Chester and State of Pennsylvania, have invented certain new and useful Improvements in Paper-Board Driers; and I do hereby declare the following to be a full, clear, and exact description of the invention, such as will enable others skilled in the art to which it pertains to make and use it, reference being had to the accompanying drawings, which form part of this specification, in which—

Figure 1 is a side elevation, Fig. 2 is a front elevation, and Fig. 3 is a perspective.

My invention has for its object to provide a machine or apparatus for drying binders' boards, junk-boards, straw-boards, leather-boards, box-boards, wood-pulp boards, or any other kind of heavy paper or paste board.

My invention consists in the peculiar construction and combination of parts hereinafter described, having reference particularly, first, to the provision of tiers of continuous pipes, each tier of the series being hinged so as to turn up or fold independently of the others, and communicating by flexible connections or rocking joints with manifolds for admitting and permitting the exit of steam; second, to the combination, with the series of continuous steam-pipes, of plates, which form tables for the reception of the boards to be dried, and serve to distribute the heat from said pipes evenly and uniformly over said boards; third, to the arrangement of the heating-pipes and the plates which rest thereon in a slightly-inclined position, so as to cause the water of condensation to flow off from the steam-pipes and a current of air or draft to be induced between the tiers of driers; fourth, to certain details of construction and combination hereinafter set forth.

Referring to the accompanying drawing, A indicates a floor or stand, on which the apparatus is stationed. B B are side frames, composed of base-plates  $b b$ , uprights  $b^1 b^1$ , and inclined stays  $b^2 b^2$ . C C are bars, pivoted in the stays  $b^2 b^2$  at  $c c$ , whereby they may be elevated or folded into an upright position and caused to rest upon one another, as hereinafter fully set forth. Each of the bars C is composed of two horizontal pieces,  $c^1 c^2$ , the

rear end of the latter being formed or provided with a block or head-piece,  $c^3$ , having trunnions which form the pinions  $c c$ . The pieces  $c^1$  are of slightly greater length than the pieces  $c^2$ , so as to project forwardly and form handles  $c^4$ , for a purpose hereinafter described.

D D are series of continuous pipes, and E E metallic plates which rest thereon, said pipes and plates being secured, as shown, to the folding-bars C C, between the pieces  $c^1 c^2$ . Each pipe of the series D D is connected at its opposite extremities  $d d^1$  with manifolds F F' for the admission of the steam and the exit thereof, respectively. G G' are the connections between the steam-pipes D D and the manifolds F F', said connections being flexible pipe or gum tubing, (for which suitable rocking joints may be substituted,) so as to permit the elevation and lowering of said pipes D, as hereinafter set forth, without interfering with the circulation of the steam through them. The ends  $d^1$  of the pipes D are brought as close as possible to the pivots  $c$ , so as to be within a short radius of the latter transverse pipes,  $d^2$ , which form continuations of the pipes D, being employed to bring the opposite ends also as near as may be to said centers  $c$ .

The bars C of the lowest tier have feet  $c^5 c^5$ , of such height that when resting upon the floor, or upon studs  $c^6$ , the said bars will incline slightly from a horizontal line downwardly and backwardly to the pivots  $c$ . The other bars C, resting thereon and on each other, as shown, have a like inclination. This inclination will cause the water of condensation in the pipes D to flow out of the same and away through the manifold F', and will induce currents of air to pass from the back part of the drier to the front between the tiers of pipes and plates.

The operation is as follows: All of the pipes and plates or tables, except the lowest one, are turned up, standing vertical, or nearly so, the lowest one being turned down, so as to be supported forwardly by the feet  $c^5$ . The boards to be dried (shown at H H in Fig. 3) are laid upon the lower plate E in sufficient number or quantity to cover the same. The other tiers or tables are then in succession turned down and receive the boards to be dried, said boards being laid one deep on the plates E, the bars

C keeping the tiers the proper distance apart, to prevent the pipes from touching the boards. The steam, which is constantly circulating through the pipes D, heats the same, and also the plates E, said plates serving to distribute such heat uniformly both above and below the boards over their entire surface, thereby causing them to dry evenly throughout their entire extent, and preventing warping.

The heat from the pipes and plates expels the moisture from the boards resting thereon, and, owing to the inclination of the tiers, induces currents of air to pass from the back to the front of the drier, carrying off such moisture, while said inclination also causes the water of condensation to flow from the front to the rear of the drier and away through the manifold F'.

If desired, plates similar to the plates E may be fastened below as well as above the pipes D, and either live or exhaust steam may be used as the heat medium.

I have used steam at thirty pounds pressure and obtained very beneficial and satisfactory results in drying; but the temperature need not be confined to the limit which such pressure imports, but may be varied within the skill and judgment of the operator. Either live or exhaust steam may be employed, and where a paper-board factory uses a steam boiler and engine the exhaust from the latter will suffice for the drying apparatus herein described.

In removing the boards after drying, they are taken first from the top tier or table, and then successively from those below, each tier or table being turned up when its boards are

removed, so as to permit easy access to the one next below. The projecting ends answer as handles in elevating and lowering or folding the tiers.

What I claim as my invention is—

1. The pipes D, hinged or pivoted at or near their back edges in suitable supports to permit their being raised and lowered or folded, substantially as and for the purpose set forth.

2. In combination with heating-pipes D, metallic plates E, applied thereto, forming rests for the boards to be dried, and causing the heat from said pipes to be distributed uniformly over said boards, as set forth.

3. The combination, with hinged or folding heating-pipes, of heat-distributing plates, secured to and moving therewith, substantially as set forth.

4. The arrangement of the tiers composed of pipes D and plates E in a slightly-inclined position, so as to induce currents of air between said tiers and to cause the flow off of the water of condensation, as set forth.

5. The combination, with pipes D and plates E, of bars C and frames B, substantially as shown and described.

6. The combination, with pipes D and manifolds F F', of flexible pipes or equivalent connections G G', substantially as and for the purpose set forth.

In testimony that I claim the foregoing I have hereunto set my hand this 26th day of September, 1878.

J. FREDERICK SHEEDER.

Witnesses:

JOS. B. CONNOLLY,  
M. DANL. CONNOLLY.