

R. S. SQUIRES & F. KAISER.  
Baling Press.

No. 210,721.

Patented Dec. 10, 1878.

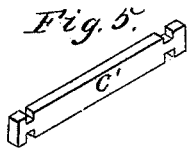
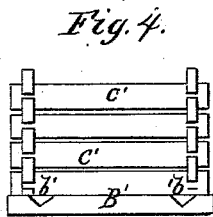
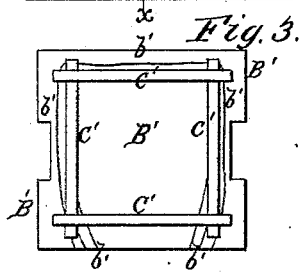
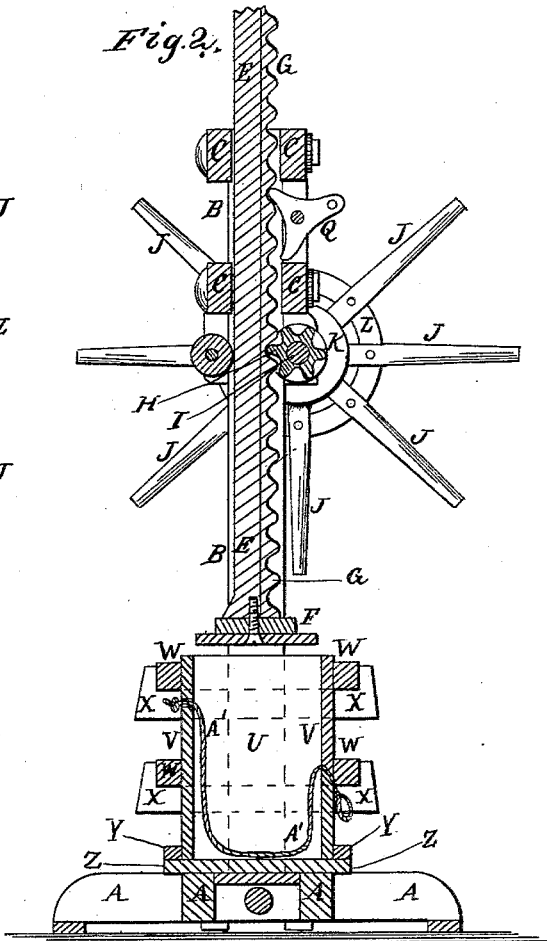
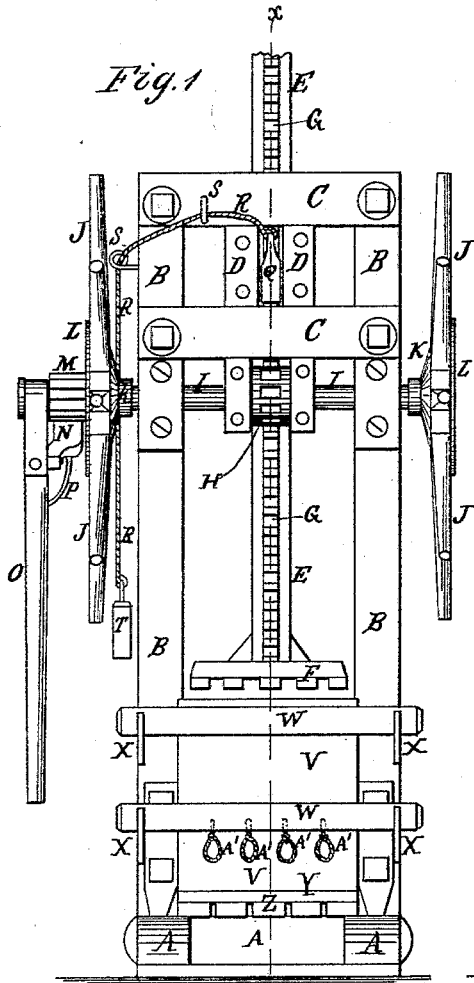

WITNESSES:

*Henry N. Miller*  
*Ch. Sedgwick*

INVENTOR:

*R. S. Squires*  
*F. Kaiser*

BY

*Munn & Co.*

ATTORNEYS.

# UNITED STATES PATENT OFFICE

ROWLIN S. SQUIRES AND FRANK KAISER, OF KANSAS CITY, MISSOURI.

## IMPROVEMENT IN BALING-PRESSES.

Specification forming part of Letters Patent No. **210,721**, dated December 10, 1878; application filed September 13, 1878.

*To all whom it may concern:*

Be it known that we, ROWLIN S. SQUIRES and FRANK KAISER, of Kansas City, in the county of Jackson and State of Missouri, have invented a new and useful Improvement in Baling-Presses, of which the following is a specification:

Figure 1 is a front view of our improved press. Fig. 2 is a vertical section of the same, taken through the line *x x*, Fig. 1. Fig. 3 is a top view of a cheese-box to adapt the press to be used in making cider, wine, &c. Fig. 4 is a front view of the same. Fig. 5 is a detail perspective view of one of the cheese-box bars.

The object of this invention is to furnish an improved press for baling hay, straw, cotton, &c., for pressing pomace grapes, &c., in cider and wine making, and for other similar uses, and which shall be simple in construction, convenient in use, and effective in operation, being capable of exerting great power.

The invention will first be described in connection with the drawings, and then pointed out in the claims.

Similar letters of reference indicate corresponding parts.

A is the base-frame of the press, to the middle part of the side bars of which are securely attached the lower ends of the posts B. The upper parts of the posts B are connected by cross-bars C, attached to their front and rear sides. To and between the middle parts of the cross-bars C are attached two upright bars, D, at such a distance apart as to form a passage or way between them for the shaft E of the follower F. To the forward side of the follower-shaft E is attached a rack-bar, G, into the teeth of which mesh the teeth of the gear-wheel H, attached to the middle part of the shaft I. The shaft I revolves in bearings attached to the forward sides of the bars D and posts B, and to its outer ends are attached the hubs of the spoke-wheels J K L. These wheels are formed by inserting spokes or levers J in the sockets of cast-iron hubs K, and connecting the said spokes J, at a little distance from the said hubs K, by ring-plates L.

With this construction the follower F may be lowered or raised by turning the wheels J K L in one or the other direction. Wheels J K L may be attached to one or both ends of

the shaft I, as may be desired. To one or both ends of the shaft I are attached ratchet-wheels M, with which engage the pawls N. The pawls N are pivoted to the levers O, and their engaging ends are held down against the teeth of the ratchet-wheels M by springs P, also attached to the said levers O. The levers O are pivoted to the ends of the shaft I.

With this construction, when the follower F has been run nearly down by means of the spoke-wheels J K L, the lever, pawl, and ratchet-wheel O N M may be used for applying greater power to complete the compression. To and between the bars D is pivoted a double pawl, Q, the arm or lever of which is made so heavy that when left free its weight will hold the lower jaw of the said pawl against the teeth of the rack-bar G, to prevent the follower F from being forced upward by the elasticity of the bale, should the wheels J K L or the levers O be accidentally released, and also to hold the follower in place while the bale is being bound. To the end of the outer arm of the double pawl Q is attached the end of a cord, R, which passes through guide-staples S, or around guide-pulleys attached to the cross-bars and post C B, and to its lower end is attached a weight, T.

With this construction, when the weight T is allowed to hang upon the cord R, it holds the upper jaw of the pawl Q against the teeth of the rack-bar G, to support the follower while the baling-box is being filled. When the follower is being run down the weight T is hung upon a nail, pin, or hook attached to the post B.

U are the sides of the baling-box, which rest against and are detachably attached to the inner sides of the posts B. The front and rear sides V of the baling-box are held in place against the ends of the sides U by cross-bars W, the ends of which rest against shoulders formed upon the end parts of the bars X, attached to the outer sides of the posts B. The front side V of the baling-box is made in two parts, the adjacent edges of which are beveled, and meet at the inner side of the lower cross-bar W. The lower ends of the sides V are supported by cleats Y, attached to the bottom Z of the baling-box, which rests upon the base-frame A. The bottom Z and the follower

F are grooved upon their inner sides to receive the bale-bands.

A' are cords, the forward ends of which rest in notches in the upper edge of the lower part of the front side V, and their rear ends are placed in V-shaped holes in the upper part of the rear side V. The cords A' are put in before the baling-box is filled, so as to be ready for use when the bale has been compressed.

When the press is to be used in making cider and wine, and for similar purposes, the baling-box is detached, and the bottom B' is placed upon the base-frame A, and the cheese-box is built upon it. The cheese-box is formed by notching the ends of bars C' to each other, as shown in Figs. 3, 4, and 5.

The bottom B' has a groove, b', formed in its upper surface, to receive the juice as it is expressed from the pomace or pulp and escapes through the spaces between the bars of the cheese-box C', and to guide it into the receiving-tank.

Having thus fully described our invention, we claim as new and desire to secure by Letters Patent—

1. The combination of the rack-bar G, the gear-wheel H, the shaft I, the spoke-wheel J K L, and the ratchet-wheel, pawl, spring, and lever M N P O, with each other, with the shaft E of the follower F, and with the frame-work A B C D of the press, substantially as herein shown and described.

2. The combination of the double pawl Q, the cord R, the guides S, and the weight T with the rack-bar G, attached to the shaft E of the follower F, and with the frame-work A B C D of the press, substantially as herein shown and described.

ROWLIN S. SQUIRES.  
FRANK KAISER.

Witnesses:

T. W. YINGLING,  
WASH. ADAMS.