

W. S. APPLETON.
Plate-Printing Press.

No. 210,741.

Patented Dec. 10, 1878.

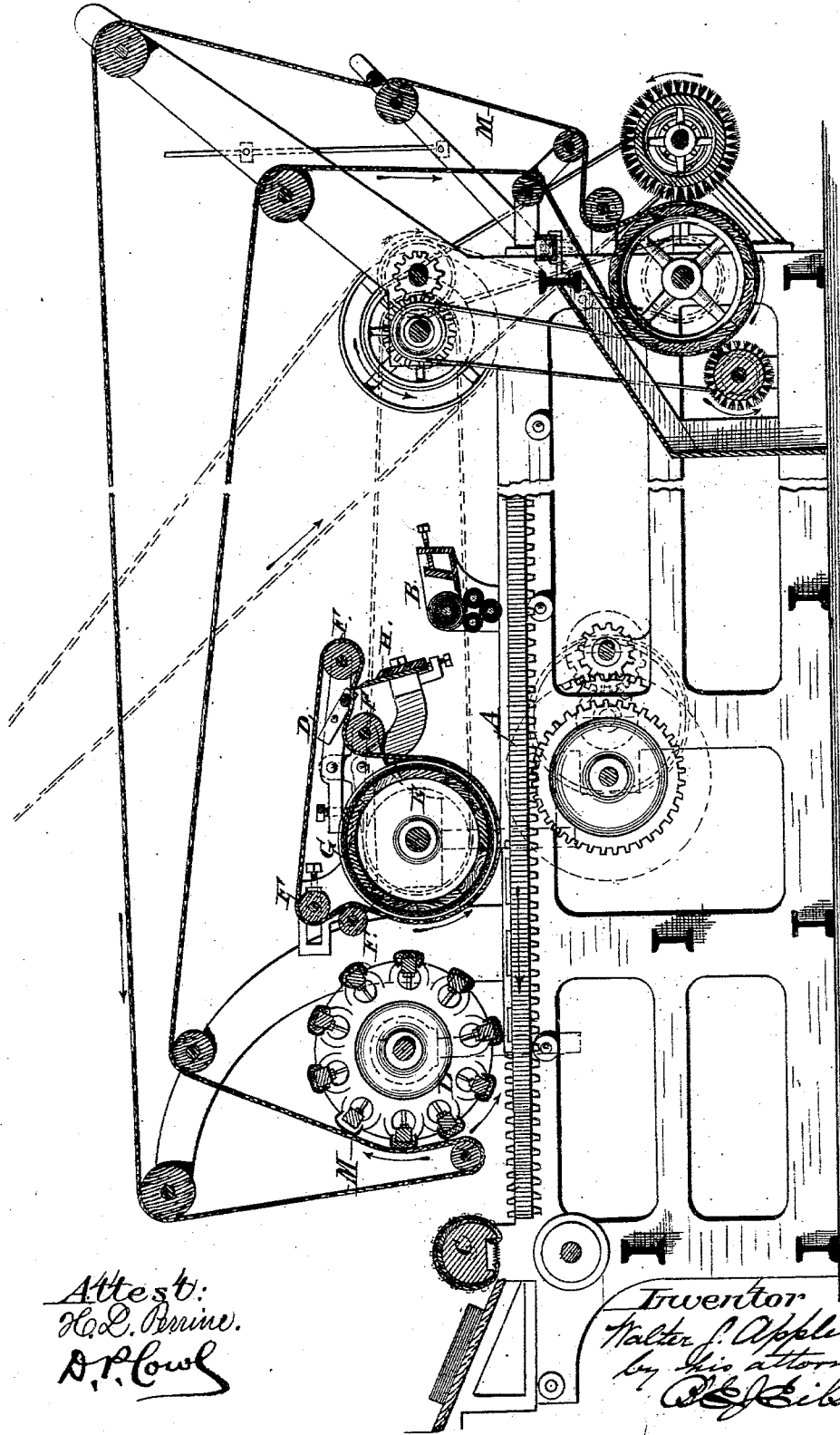

Attest:
H. L. Perrine.
A. P. Cowl

Inventor
Walter S. Appleton
by his attorney
A. P. Cowl

UNITED STATES PATENT OFFICE.

WALTER S. APPLETON, OF NEW YORK, N. Y.

IMPROVEMENT IN PLATE-PRINTING PRESSES.

Specification forming part of Letters Patent No. **210,741**, dated December 10, 1878; application filed September 14, 1878.

To all whom it may concern:

Be it known that I, WALTER S. APPLETON, of New York, in the county of New York and State of New York, have invented certain Improvements in Plate-Printing Presses, of which the following is a specification:

This invention relates to plate-printing presses in which the cleaning or wiping and the polishing of the engraved plate previous to each impression are effected by automatic means.

In the practical operation of plate-printing presses of this character great difficulty has been experienced in effecting the wiping of the engraved plate with that thoroughness and nicety indispensable to the production of good, clean, and sharp impressions. It is owing to this difficulty, mainly, that plate-printing is still very largely practiced with hand-presses, where the wiping is done by hand.

Among the best automatic wipers known anterior to my invention may be mentioned the traveling endless belt and the revolving drum.

The traveling endless belt was arranged around small rollers, one of which was so located as to cause the belt to wipe the plate in passing, and the belt was driven from one of the other rollers. The revolving drum had an elastic or somewhat yielding backing under a surface-covering of leather.

In the practical application of these two styles of wipers it was ascertained that both were defective, and could not be relied upon at all for steady work.

After patient daily experiments for many months with a full-sized plate-printing press, at this day in full practical operation, I finally devised a wiper which has proved a perfect success, and which is now doing steady work day in, day out. This improved wiper constitutes the principal feature of my invention.

It consists of an endless cloth or woven belt combined with a positively-driven drum, around which the belt is lapped far enough by guide-rollers to give the drum the required tractive power upon the belt for running it with precision and uniformity. The drum has a some-

what elastic or yielding surface, and brings the endless belt in contact with the engraved plate to wipe off the surplus ink.

The annexed drawing represents a vertical longitudinal section of a reciprocating plate-printing press provided with my improved wiper.

The engraved plate is secured upon the reciprocating bed A, by which it is moved alternately under the inking apparatus B to be inked, and under the impression-cylinder C to make impressions.

On its return from the inking apparatus the engraved plate is wiped, to remove the surplus ink, by the wiper-belt D, running in a contrary direction. The wiper-belt is driven by the large drum E, which is located directly over the path of the engraved plate, and sustains the belt at the point where it wipes said plate.

The wiper-belt is made of cloth, or other woven fabric suitable for this purpose, and encircles a large portion of the surface of drum E, so that the latter has great tractive power on the belt.

In connection with drum E, a series of guide-rollers, F, are used to sustain and direct the wiper-belt.

The drum E is constructed with a surface of yielding material, G, so as to make it somewhat elastic, in order that the wiper-belt may wipe with an elastic touch.

A knife, H, scrapes the surplus ink from the wiper-belt directly, as shown in Fig. 1, where it bears on the belt between two adjacent rollers. The knife H has a dull edge, of course.

The cleaning of the engraved plate is completed by the polisher L, constructed as shown, and operating in connection with the usual endless polisher-belt M, impregnated with whiting, as usual.

As the general construction and mode of operation of plate-printing presses of the character illustrated in the drawing hereto annexed is well known to persons skilled in the art, it is deemed unnecessary to enter upon a description of the same.

My invention may be applied to other styles of plate-printing presses now known.

What I claim as my invention, and desire to secure by Letters Patent, is—

A wiper for a plate-printing press, composed, substantially as before set forth, of an endless fibrous wiper-belt and a revolving elastically-surfaced drum, which drives the belt and brings it in contact with the plate.

In testimony whereof I have signed my name to the foregoing specification in the presence of two subscribing witnesses.

WALTER S. APPLETON.

Witnesses:

B. E. J. EILS,
N. CALLAN.