

J. CHAUMONT.  
Manufacture of Sheet-Metal Vessels.  
No. 210,751. Patented Dec. 10, 1878.

*Fig. 1.*

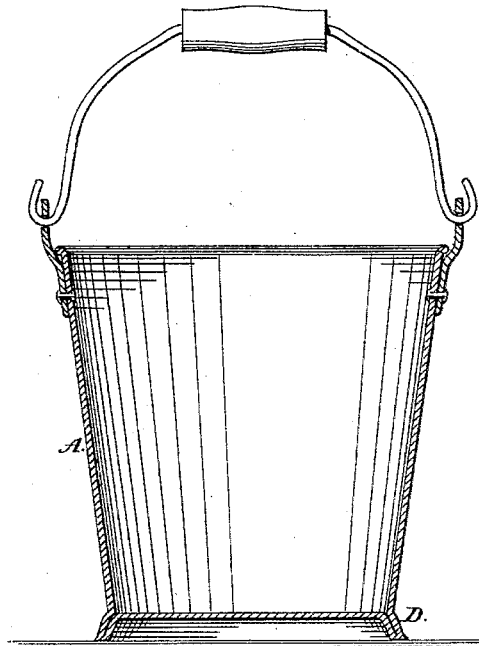

*Fig. 2.*

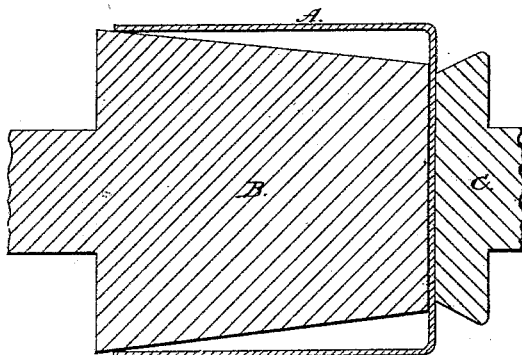

*Fig. 3.*

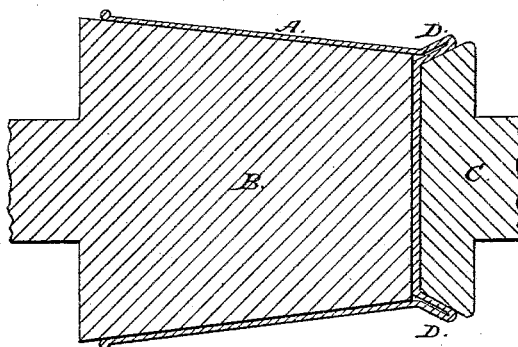

Witnesses,  
H. W. Howard  
John Tyler

Inventor,  
Jules Chaumont  
By atty Wm. C. Winters

J. CHAUMONT.  
Manufacture of Sheet-Metal Vessels.  
No. 210,751. Patented Dec. 10, 1878.

*Fig. 4.*

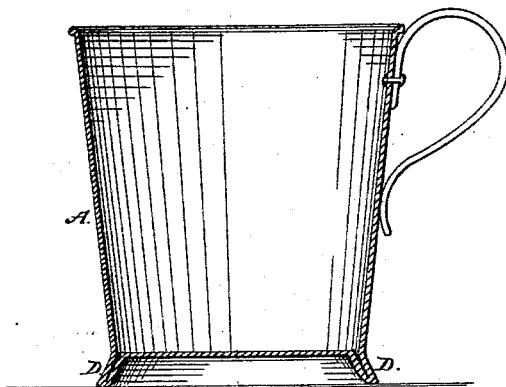

*Fig. 5.*

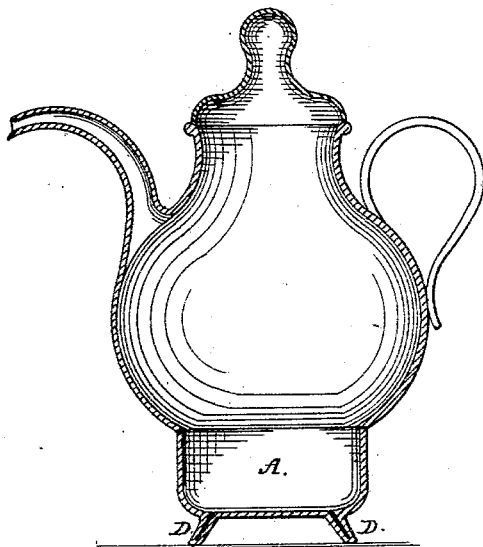

*Witnesses;*  
*A. W. Howard*  
*John Tyler*

*Inventor,*  
*Jules Chaumont*  
*By atty. J. M. Crutcher*

# UNITED STATES PATENT OFFICE.

JULES CHAUMONT, OF WOODHAVEN, NEW YORK, ASSIGNOR TO LALANCE & GROSJEAN MANUFACTURING COMPANY.

## IMPROVEMENT IN MANUFACTURE OF SHEET-METAL VESSELS.

Specification forming part of Letters Patent No. **210,751**, dated December 10, 1878; application filed October 23, 1878.

### *To all whom it may concern:*

Be it known that I, JULES CHAUMONT, of Woodhaven, in the county of Queens and State of New York, have invented certain new and useful Improvements in the Manufacture of Sheet-Metal Vessels; and I do hereby declare that the following is a full and exact description thereof, reference being had to the accompanying drawings, making a part of this specification.

My invention relates to certain new and useful improvements in the manufacture of sheet-metal vessels. It has for its object the production of a seamless vessel with foot or support, all made in a single piece; and with this end in view, my invention consists in the method adopted to produce the article, and also in the article itself, as an improved manufacture.

Prior to my invention it has been customary in the manufacture of sheet-metal vessels with an annular foot or support to form the latter from a separate piece, and secure the same in position by soldering or riveting.

Among the disadvantages attending this mode of manufacture may be mentioned that it requires considerable waste of material in forming the foot by the usual spinning process. As the central portion of the blank must of necessity be cut out and thrown away, the joint between the foot and the vessel is necessarily the weakest point in the structure, while it should be the strongest, and the time and labor consumed in the construction add very materially to its cost.

It has also been customary to form sheet-metal vessels with the foot by stamping from a single piece between dies; but this process is likely to crimp or fracture the metal, and involves considerable power and complexity of machinery in producing different sizes of a given article.

All of these disadvantages are overcome by my invention, and a vessel is produced not only at less cost, but involving in its construction great strength and durability, as well as neatness of design.

In order that those skilled may understand my invention, I will proceed to describe the various steps in the process of manufacture

and the peculiarly novel features in the resulting structure, referring by letters to the accompanying drawings, in which—

Figure 1 is a central vertical section of a water-pail involving the features of my invention; Figs. 2 and 3, longitudinal central sections of the cup or cylinder, Fig. 2, as it comes from the forming-dies, arranged upon and between cone-shaped chucks or mandrels for spinning. The former represents the cup before, and the latter the cup after, the spinning process. Fig. 4 represents a vertical central section of a drinking-cup complete with handle attached; and Fig. 5 represents a similar view of a coffee-pot, illustrating the application of my invention to vessels of irregular shape, and composed of more than one piece.

Similar letters denote the same parts in the different figures.

In the manufacture of my improved vessel, I take an ordinary piece of sheet metal, and, by the usual or any suitable means, form a cup or cylinder, A. I then place this cup over a cone-shaped chuck or mandrel, B, with the end of the chuck against the inside of the bottom of the cup, which is held firmly in place by a smaller cone-chuck, C, bearing against the outside of the bottom, the diameters of the chucks relatively to each other being about as shown in the drawing. The chucks B C, being in a lathe, are caused to rotate, carrying with them the blank or cup A, which is spun down closely upon the chuck B, causing the excess of metal to travel and buckle upon the smaller chuck, C, producing the flaring double annular foot D.

Of course, the depth of the foot and the flare of the same, as well as of the sides of the vessel, will depend upon the length and design of the spinning chucks or mandrels.

It will be seen that the vessel complete—body, bottom, and foot—is all in one piece, and that the metal is double, and strongest at the very points where the greatest strength is required.

Where the desired design of the vessel is such that the entire height of the same cannot be made of a single piece, as illustrated at Fig. 5, the lower portion of the body and the foot are formed of a single piece, and then the

top or ornamental portion subsequently secured in position in any suitable manner.

Of course I do not wish to confine myself to any of the exact forms shown, as they may be varied without departing from the spirit of my invention.

Any space that may exist between the two thicknesses of the annular foot may, if necessary, be filled with solder, tin, or in any other suitable manner.

What I claim as new, and desire to secure by Letters Patent, is—

The mode of forming annular seamless ves-

sels with annular supporting flange or foot, by spinning a blank, such as described, down the sides of one and up the sides of another cone-shaped mandrel, the mandrels holding the bottom of the blank rigidly between their disk-faces, substantially as set forth.

In testimony whereof I have hereunto set my hand and seal this 18th day of October, A. D. 1878.

JULES CHAUMONT. [L. S.]

In presence of—

JNO. S. PATTERSON,

WM. R. WANDLESS.