

T. A. EDISON
Vocal Engine.

No. 210,767.

Patented Dec. 10, 1878.

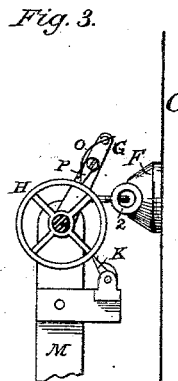
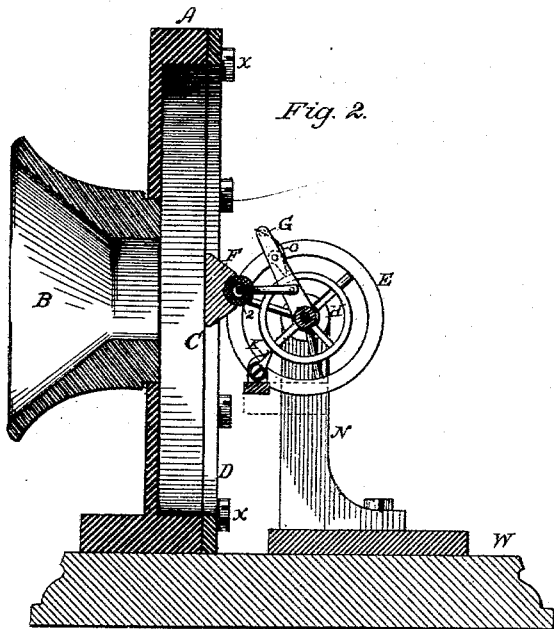
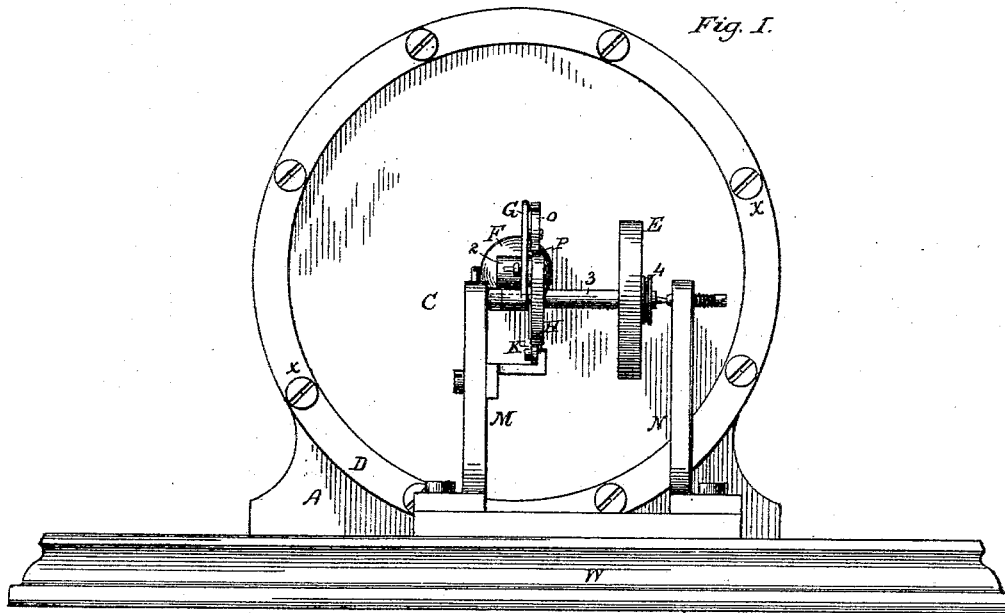

Witnesses
Clarence Poole
W. H. Winter.

Inventor:

Thomas A. Edison

UNITED STATES PATENT OFFICE.

THOMAS A. EDISON, OF MENLO PARK, NEW JERSEY.

IMPROVEMENT IN VOCAL ENGINES.

Specification forming part of Letters Patent No. **210,767**, dated December 10, 1878; application filed November 27, 1878.

To all whom it may concern:

Be it known that I, THOMAS A. EDISON, of Menlo Park, Middlesex county, State of New Jersey, have invented certain new and useful Improvements in Vocal Engines; and do hereby declare the following to be a full, clear, and exact description of the invention, such as will enable others skilled in the art to which it pertains to make and use it, reference being had to the accompanying drawings, which form part of this specification.

The object of my invention is to transform the vibrations of a diaphragm or other body capable of being set in vibration by sound-waves into continuous rotation of a shaft, to act as a prime motor for various light mechanisms.

My invention consists in the combination, with a diaphragm sensitive to sound-waves, of a shaft between centers having a fly-wheel attached, and combining the diaphragm therewith by a friction-clutch, which, when reciprocated by the vibration of the diaphragm, acts upon a shaft so as to continuously rotate the same when the diaphragm is actuated by sound-waves.

Figure 1 is a front view of my apparatus. Figs. 2 and 3 are side views of the same.

In Fig. 1, C is the diaphragm, of any convenient material, which is secured to the frame A by the ring D and screws X X. B is a mouth-piece for concentrating the air-waves upon the diaphragm. F is a cork secured to the center of the diaphragm. 2 is a rubber tube, into which a pin is secured. This pin connects the rubber with the reciprocating lever G, whose fulcrum is upon the shaft 3.

P is a click or pawl resting upon the wheel H, and pressed against its surface by the spring O. K is another click, secured to the upright M, which serves to prevent a backward motion of the shaft. E is a fly-wheel, for storing, by momentum, the intermittent power, and thus keeping the shaft in continu-

ous rotation. The shaft 3 runs in centers between the uprights M and N. The whole is secured to the base W.

The action is as follows: When the mouth is placed in proximity to the mouth-piece B, and several words are spoken, or a musical note given, the sound-waves, striking the diaphragm, set it in vibration. This, in turn, reciprocates the lever G, causing the shaft to be carried forward a small distance at every vibration, and the momentum of the fly-wheel transforms these minute impulses into continuous rotation of the shaft. A small grooved pulley, 4, Fig. 1, is attached to the shaft, in the groove of which a continuous thread or band may pass to any light mechanism, and thus give motion.

I do not wish to confine myself to any particular mechanism for transforming the vibratory motion of the diaphragm into continuous motion, as a ratchet-wheel and click and many other well-known mechanical equivalents may be used. Neither do I wish to confine myself to a pulley and cord for connecting the prime mover to the apparatus to be set in motion, as a worm and wheel or toothed wheel or friction-wheel may be substituted instead.

A large cone may be inserted in the mouth-piece B, for collecting extraneous sounds and causing them to move the diaphragm.

This apparatus is useful for giving motion to clocks and other small apparatus requiring minute power.

I claim as my invention—

A vocal engine consisting of a diaphragm or other body capable of being set in motion by sound-waves, a shaft, and reciprocating mechanism, substantially as and in the manner set forth.

THOMAS A. EDISON.

Witnesses:

WM. CARMAN,
CHAS. BATCHELOR.