

D. EDDY.  
Feather Renovator.

No. 210,768.

Patented Dec. 10, 1878.

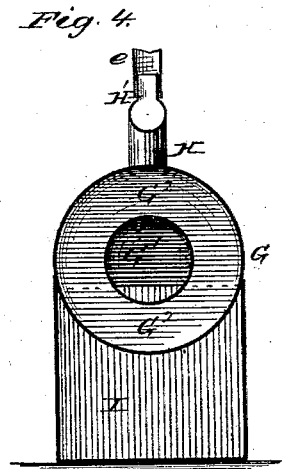
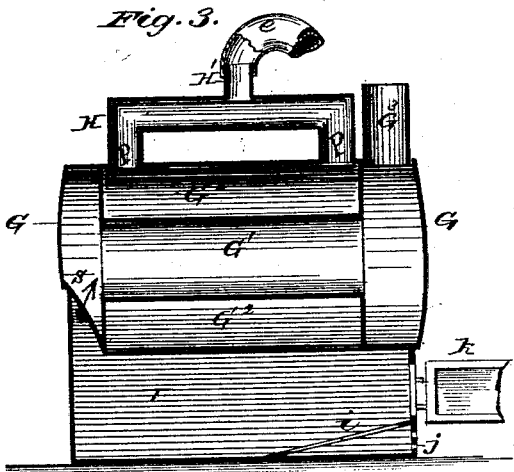
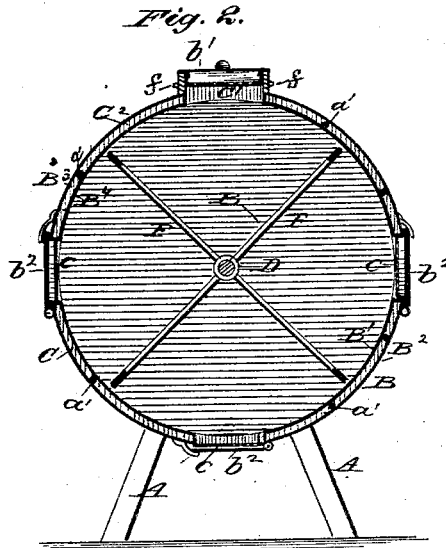
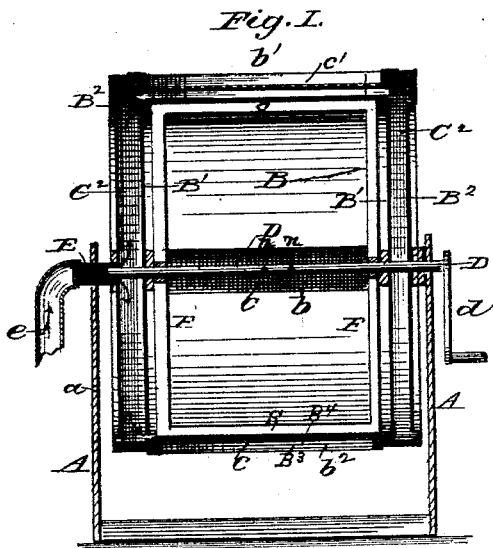

Witnesses

Red. G. Dietrich

Will Blumhundra.

Inventor

David Eddy  
By Myers & Co.  
Atty.

# UNITED STATES PATENT OFFICE.

DAVID EDDY, OF SIDNEY, ILLINOIS, ASSIGNOR TO JAMES WHITCOMB.

## IMPROVEMENT IN FEATHER-RENOVATORS.

Specification forming part of Letters Patent No. **210,768**, dated December 10, 1878; application filed September 14, 1878.

*To all whom it may concern:*

Be it known that I, DAVID EDDY, of Sidney, in the county of Champaign and State of Illinois, have invented certain new and useful Improvements in Feather-Renovators; and I do hereby declare that the following is a full, clear, and exact description of the invention, which will enable others skilled in the art to which it appertains to make and use the same, reference being had to the accompanying drawings, and to letters of reference marked thereon, which form a part of this specification.

In the accompanying drawings, Figure 1 represents a vertical longitudinal section of my improved feather-renovator; Fig. 2, a vertical transverse section of the same; Fig. 3, a vertical longitudinal section of my steam-boiler; Fig. 4, a vertical transverse section of the boiler.

In the drawing, B<sup>4</sup> marks the inner, and B<sup>3</sup> the outer, longitudinal wall of the renovator, and B<sup>1</sup> and B<sup>2</sup> indicate its lateral walls. The outer walls are made of sheet-iron and the inner walls of zinc, located about an inch apart, and these walls form a continuous recess around the renovating-chamber, excepting where the screens interpose for admission of steam, which enters it through the pipe E, which connects with the hollow shaft D. The steam passing through this space heats the zinc, which communicates its heat to and dries the feathers, and finally escapes through the apertures a' a'.

The steam is generated in the boiler G<sup>2</sup>, in connection with the furnace I, and conveyed into the shaft D by means of the conduit e and tube E.

The agitator or reel B consists of the radial arms or wings F F, connected by the cross-bars s s and b. Its bearings are on the same shaft, D, as those of the walls B<sup>1</sup> and B<sup>2</sup>, and the shaft is pivoted in the standard A. Hence the agitator may be freely rotated by the crank d.

The shaft D, which is operated by crank d, is a hollow pipe, and hence the steam not only passes through the tube E into the recess formed by the hollow walls of the device, and out of the apertures a' a', provided in the lateral wall opposite to the wall through which it

entered, but also into the shaft D, which is provided with the orifices n n for its escape into the renovating-chamber.

At the bottom of the machine is a screen, C, provided with a closely-fitting cover, b<sup>2</sup>, which is detachable, and thus affords a means of cleansing the receptacle. The screens C C are provided with covers b<sup>2</sup> b<sup>2</sup>, which latter are detachable, in order that the screens may be closed, and egress of steam thereby prevented, when desirable.

When the feathers have been cleansed it becomes necessary to dry them, and as a part of the drying process the covers b<sup>2</sup> b<sup>2</sup> are removed in order that the steam may escape from the main chamber. The walls or casing of the chamber are heated by the steam in the recess, and thus heat is imparted to the feathers, which, after being cleansed, are dried and prepared for removal from the renovator.

C' marks an opening through which the feathers are inserted or removed.

The points f f are rigidly secured to the outer surface or vertical frame of the aperture for the purpose of hooking thereto the bed-tick, as a means of facilitating the process of removing the feathers from or emptying them into the renovator.

In the process of renovating the feathers they are loosened by the wings of the renovator, which are kept constantly in motion, and steam is thus caused to permeate the entire mass.

During the process of drying the feathers the lower door, b<sup>2</sup>, is opened, and the agitation caused by the fan when revolved drives out the dust and dirt.

In the lower part of the steam-generator G is located the furnace I, with grate i and door K. The opening G<sup>1</sup>, which extends longitudinally through the boiler G<sup>2</sup>, is designed for admission of heat and product of combustion, which passes into the cylinder thus formed. The boiler is fitted closely upon the furnace I, to prevent the escape of heat and smoke, which passes up through the intervening space S into the cylinder G<sup>1</sup> and out at the chimney G<sup>3</sup>.

The small horizontal cylinder, H, from which projects the vertical supply-pipe H', is de-

signed to prevent the boiling water from being conveyed into the feather-renovator through the conduit *e*. It is connected with the vertical pipes P P, which open into the boiler G<sup>2</sup>.

In this connection I would state that I am aware that steam has been employed in a revolving steam-chamber for cleansing feathers, and that hollow cylinders having reels therein have also been used as receptacles for the feathers to be cleansed and agitated.

I claim—

1. The combination of the hollow shaft D, tube E, conduit *e*, and boiler G<sup>2</sup>, substantially as shown, and for the purpose specified.

2. The hollow walls B<sup>1</sup> and B<sup>2</sup>, with hooks *f f*, screens C C, having covers *b<sup>2</sup> b<sup>2</sup>*, and screen C', with cover *b<sup>1</sup>*, in combination with tube E and conduit *e* and boiler G<sup>2</sup>, substantially as shown and described.

In testimony that I claim the foregoing as my own I affix my signature in presence of two witnesses.

DAVID EDDY.

Witnesses:

FRANCIS B. ROYSTON,  
JAMES TAPP.