

Z. M. LANE & W. S. HILL.
Time-Registering Clock.

No. 210,788.

Patented Dec. 10, 1878.

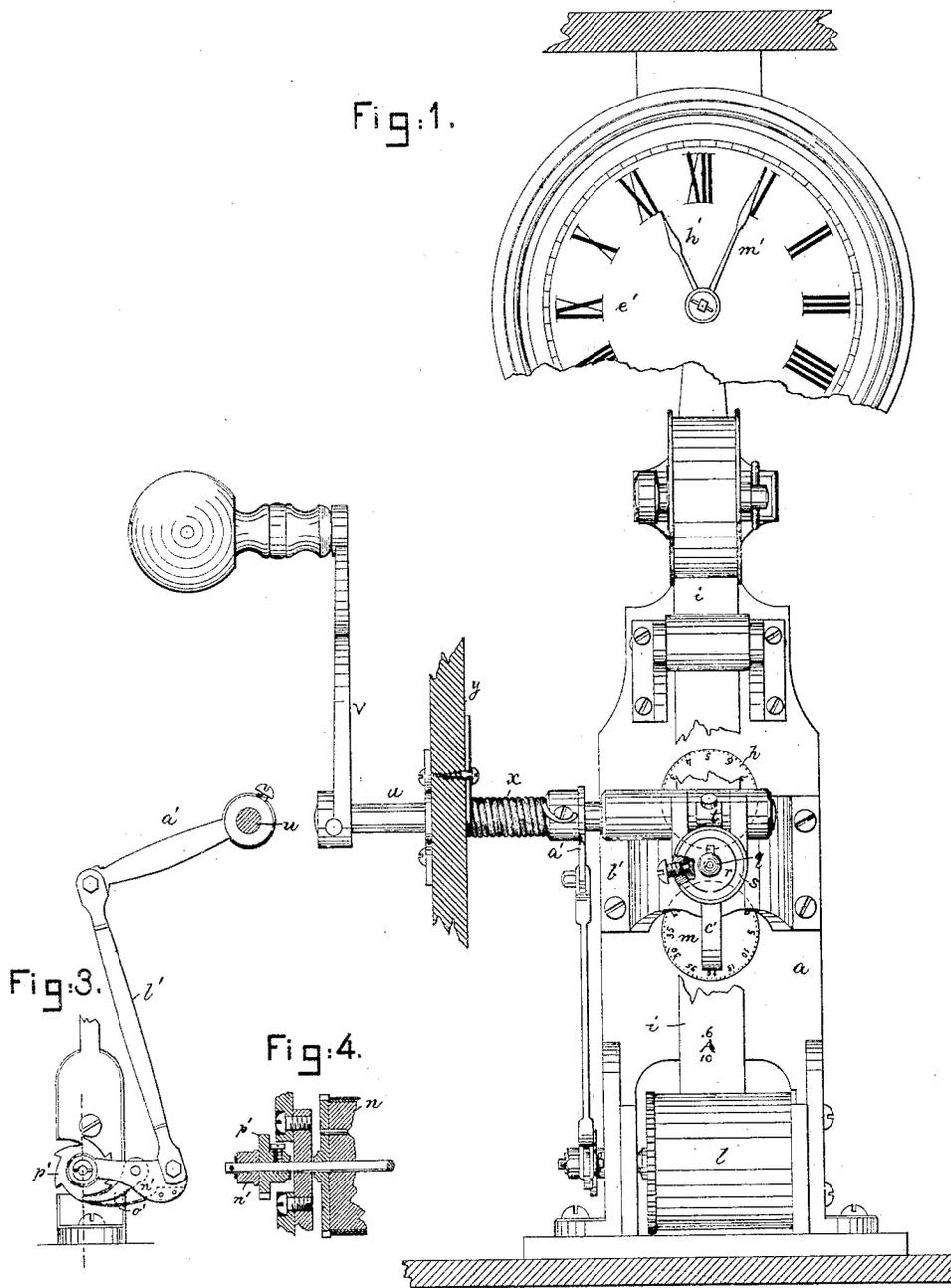

Witnesses.
L. F. Connor.
N. E. Whitney.

Inventor.
Z. M. Lane & W. S. Hill.
by Crosby & Gregory Attys

Z. M. LANE & W. S. HILL.
Time-Registering Clock.

No. 210,788.

Patented Dec. 10, 1878.

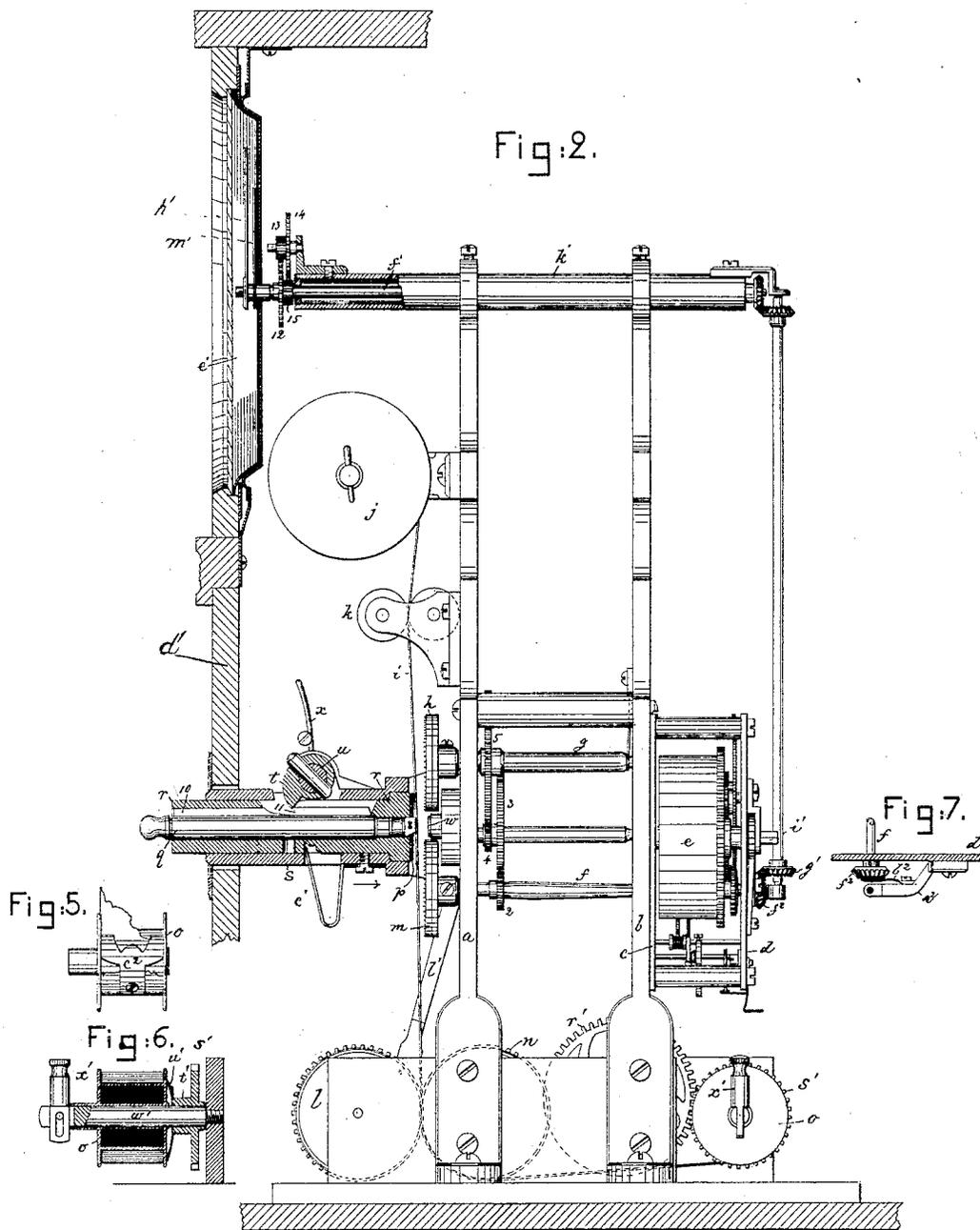

Witnesses.
L. F. Connor
A. E. Whitney

Inventor.
Jonas M. Lane & Warren S. Hill
by Crosby & Gregory, Attys

UNITED STATES PATENT OFFICE.

ZENAS M. LANE, OF ROCKLAND, AND WARREN S. HILL, OF BOSTON, MASS.

IMPROVEMENT IN TIME-REGISTERING CLOCKS.

Specification forming part of Letters Patent No. **210,788**, dated December 10, 1878; application filed June 3, 1878.

To all whom it may concern:

Be it known that we, ZENAS M. LANE, of Rockland, county of Plymouth, State of Massachusetts, and WARREN S. HILL, of Boston, county of Suffolk, State of Massachusetts, have invented an Improvement in Time-Registering Clocks, of which the following is a specification:

This invention relates to a time-registering clock adapted for factory, store, school, or other purposes, to register for workmen, clerks, or scholars the time of their arrival or departure, or both.

In this invention certain registering-wheels moving in unison, one with the hour and the other with the minute hand of a clock, and provided with embossing figures or characters, are placed in such relation one with the other, and are so moved to indicate correct time, that a key and pad co-operating therewith, set in motion by a workman, clerk, or scholar, such person being provided with his or her own key, will cause a recording-strip, preferably paper, to be pressed in contact with the registering-wheels, thereby indicating the hour and minute when such operation takes place, and with whose key.

In this way it will be obvious that the arrival and departure of each workman may be kept upon the recording-strip, subject to examination, as may be required, and a person to keep the time of arrival and departure of workmen may be dispensed with, this registering mechanism or clock keeping the workmen's time faithfully.

Figure 1 represents, in front elevation, a time-registering clock containing one embodiment of this invention; Fig. 2, a side elevation thereof, partly in section; Figs. 3 and 4, details of the mechanism for operating the drum or wheel which acts to feed the recording-strip; Fig. 5, a view of the strip-receiving reel or drum; Fig. 6, a sectional detail thereof; and Fig. 7, a detail to be hereinafter referred to.

The uprights *a b* or frame are of suitable size and shape to sustain the working parts. The registering mechanism herein described is set in motion by a clock-train shown inclosed between the plates *c d*, supported by the upright *b*. This clock-train, driven by a strong spring in the

barrel *e*, or by a weight, is and may be of any usual or suitable construction, and need not, therefore, be herein specifically described further than to say that the axle *f* is that which corresponds with that axle in a clock which sets in motion the minute-hand, and that the axle *g*, set in motion at a slower speed by the train of gear 2 3 4 5, corresponds with that axle which sets in rotation the hour-hand of a clock. Upon axle *f* is attached the minute-register, (shown as a wheel or disk, *m*), and upon axle *g* the hour-register, (also shown as a wheel or disk, *h*.)

The former-wheel is provided with figures or points to indicate minutes, and the latter with figures or points to indicate hours, (see Fig. 1,) and the peripheries of the two wheels or disks are so moved with relation to each other by the clock-train that the hour and minute figures will come opposite each other, and always indicate, on a certain line—in this instance, a vertical line—the hour and minute as accurately as would a clock.

To render these registers available for recording time of arrival and, if desired, departure of workmen, &c., a recording-strip, *i*, of paper or other suitable material, mounted on a reel, *j*, and passed between directing-rollers *k* and feed-rollers *l n*, and thence to a receiving-reel, *o*, is placed in front of the registers, and a pad, *p*, and key *q* are made at the time of arrival or departure of the workman or other person to force the recording-strip against the register-wheels, and record for that person designated by the letter, figure, or character upon the end of the key his or her arrival or departure.

The pad *p*, preferably of leather or other soft or yielding material, is shown as attached at the end of a plunger, *r*, in a sleeve, *s*.

The key *q* has at its inner end a head, *8*, the face of which has upon it a raised letter or other character proper to designate one workman, (a book of reference being kept to indicate to which person each key belongs,) and along the body of the key is a fin, *10*, to enter a slot in the plunger, (see Fig. 2,) to maintain the key in upright position. This fin is notched, as at *11*, as is also the shank of the plunger *r*, to permit the cam *t* or an arm or toe on the shaft *u*, when turned by the work-

man seizing the handle *v*, to descend into an opening in the sleeve *s*, and act against the shoulders of the key and of the plunger, force the key, plunger, and pad forward in the direction of the arrow, Fig. 2, and press the strip *i* against the registers *h m*, and emboss or imprint upon the strip the hour and minute of the day at which such movement took place. The head 8 acts against a bed, *w*, placed opposite it behind the strip, so that with each record of hours and minutes there also appears a letter, character, or number to designate a person, and subsequent inspection of the strip will show the arrival or departure of each person owning and operating a key.

The key, when the cam *t* is elevated into normal position by the spring *x*, connected with the clock-case *y* or other bearing, and with the hub of arm *a'*, may be easily and freely inserted and withdrawn from the plunger.

The screw *b'* in sleeve *s* (see Fig. 1) enters a groove in the plunger and insures the movement of the latter in a right line, and the spring *c'* retains or moves the plunger backward from the strip when the handle *v* is released, a portion of the plunger also acting upon a portion of the fin 10 of the key to simultaneously carry it backward from the strip.

The peripheries of the directing-rollers *k* and feed-rollers are so placed that the strip is retained from contact with the face of the registers *h m*, except when moved positively by the pad.

An apparatus or clock of this kind kept in a certain place and operated by a watchman, so as to move forward only the pad, would indicate the time of such visit.

In Fig. 2, *d'* represents the front portion of a case to inclose the mechanism so far described, and the dial *e'* is like that of an ordinary clock, hour and minute hands *h' m'* traveling over such dial, all as usual. In this instance of this invention it is provided that the apparatus also indicates visibly to the workman or other person looking at it the actual time. Said minute-hand derives its motion from a bevel-pinion, *f²*, on axle *f*, its engaging a bevel-pinion, *g'*, on shaft *i*, connected by bevel-gears (see Fig. 2) with a shaft, *f'*, the latter held in a long bearing, *k'*, at the top of pieces *a b*.

The hour-hand derives its motion from shaft *f'*, through the train of gear 12, 13, 14, 15. It will be obvious that the shafts *f f'*, which operate the register *m*, and also the minute-hand, move in unison and at the same speed; so the apparatus will operate as a clock only, or as a register, or for both purposes.

The arm *a¹* on the shaft *u*, at each forward movement of the pad and plunger, through the link *l'*, lifts an arm, *n'*, provided with a pawl, *o'*, so that it is made to travel over and engage a different tooth of a ratchet, *p'*, on the shaft of the feed-wheel *n*, and as the arm descends after the operation of the plunger

the feed-wheel is rotated far enough to carry the portion of the strip just embossed or printed beyond the action of the plunger at its next forward movement. This feed-wheel *n* is one of a pair, *l n*, geared together by toothed wheels so as to rotate in unison, their peripheries engaging the strip at both sides.

The toothed gear on feed-wheel *n* meshes with an intermediate pinion, *r'*, which engages a pinion, *s'*, connected with a hub, *t'*, provided with a friction device, *w'*, and mounted upon a stud or pin, *w'*, the friction device engaging one head of the receiving-reel *o* also on said stud, and rotating said reel to wind up the strip *i*. This reel may be removed by turning down the holder *x'* so that it falls in line with stud *w'*.

Shaft *i'* is supported by a bracket, *a²*, and the end of axle *f* takes a bearing against a spring, *b²*.

The reel *o* has at its barrel a strip-holding spring, *c²*, by which to attach the end of the strip to the reel.

If hours only are to be recorded the minute-register may be omitted.

Instead of the disks *h m* the figures might be arranged on cylinders or other shaped registers suitably moved progressively past the presser.

If desired the hour and minute registers and pad may be duplicated and placed side by side, so that several workmen may register their time simultaneously.

We do not claim a type in connection with one of two time-wheels to indicate the impression of one wheel from that of the other.

We claim—

1. In a time-recording apparatus, registers for hours and minutes, and a reciprocating pad and key, arranged in a carrier or plunger common to both, to record the time and impress upon a strip a character or letter to indicate a person, substantially as described.

2. In a time-recording apparatus, registers for hours and minutes, a pad, a key, a carrier or plunger common to both, and mechanism to reciprocate the pad and key, to emboss or impress upon a strip the time and a character or letter to indicate the person, substantially as described.

3. The plunger *r* and pad *p*, and registers *h m*, and the key *q*, provided with a notch, 11, combined with a bed, *w*, interposed between the registers, substantially as described.

4. The sleeve *s* and notched plunger and key, combined with the cam *t* and shaft *u*, substantially as described.

In testimony whereof we have signed our names to this specification in the presence of two subscribing witnesses.

ZENAS M. LANE.
WARREN S. HILL.

Witnesses:

G. W. GREGORY,
L. F. CONNOR.